

# Physics

For Rwanda Schools

Senior 3

Teacher's Guide

**N. Kaboyo**

**C. Kariuki**

**P. Kimani**



**LONGHORN**  
PUBLISHERSLIMITED  
expanding minds

Published by

Longhorn Publishers (Rwanda) Ltd  
Remera opposite COGE Bank  
P.O. Box 5910  
Kigali, Rwanda

Longhorn Publishers (Kenya) Ltd  
Funzi Road, Industrial Area  
P.O. Box 18033-00500  
Nairobi, Kenya

Longhorn Publishers (Uganda) Ltd  
Plot 4 Vubyabirenge, Ntinda  
P. O. Box 24745  
Kampala, Uganda

Longhorn Publishers (T) Ltd  
New Bagamoyo Road / Garden Road  
Mikocheni B, Plot No. MKC/MCB/81  
P.O. Box 1237  
Dar es Salaam, Tanzania

© N. Kaboyo, C. Kariuki, P. Kimani 2017

All rights reserved. No part of this publication may be reproduced, stored in a retrieval system or transmitted in any form or by any means, electronic, mechanical, photocopying, recording or otherwise without the prior written permission of the Copyright owner.

First published 2017

**ISBN 978 9997 77 113 1**

Printed by Ramco Printing Works Ltd,  
Unit 2, Ramco Industrial Complex,  
Before Imara Daima Turn off, Mombasa Road,  
P. O. Box 27750 - 00506,  
Nairobi, Kenya.

# Contents

<b>Part 1: Introduction .....</b>	<b>1</b>
Basic Information .....	1
Effective teaching and learning of S3 Physics.....	8
Content Maps .....	14
Planning to teach.....	34
Assessment and evaluation methods.....	38
<b>Part 2: Unit to unit guide</b>	
<b>Unit 1:</b> Graphs of linear motion.....	43
<b>Unit 2:</b> Friction force and Newton's laws of motion .....	58
<b>Unit 3:</b> Applications of atmospheric pressure .....	80
<b>Unit 4:</b> Renewable and non-renewable energy .....	93
<b>Unit 5:</b> Heat transfer and quantity of heat .....	111
<b>Unit 6:</b> Laws of thermodynamic .....	126
<b>Unit 7:</b> Introduction to electro-magnetic induction.....	142
<b>Unit 8:</b> Electrical power transmission .....	154
<b>Unit 9:</b> Electric Field Intensity .....	171
<b>Unit 10:</b> House electric installation .....	181
<b>Unit 11:</b> Basic alternating current circuits .....	196
<b>Unit 12:</b> Refraction of light .....	207
<b>Unit 13:</b> Telecommunication channels .....	218
<b>Unit 14:</b> Properties of physical process affecting plant growth.....	227
<b>Unit 15:</b> Environmental phenomena and related physical concepts .....	242



# PART 1: INTRODUCTION

## 1.1: Basic Information

### 1.1.1 Organisation of the book

This teacher's guide is organised into two main sections.

**Part 1** is the general **introduction** section detailing information on competence based curriculum and pedagogical issues.

The main elements of Part 1 are:

- **1.1: Basic information-** It gives a brief overview of the organisation of the this and background to the new curriculum which details the types of competences and their acquisition, crosscutting issues to be addressed during learning, special needs education and inclusivity.
- **1.2: Pedagogical approaches-** It highlights the teacher's and learner's roles for effective teaching/learning of Physics, teaching/learning resources, grouping learners for learning and teaching methods
- **1.3: Assessment and evaluation methods-** It gives an overview of types of assessment, record keeping and how to report the learners performance to parents.
- **1.4: Content map:** It gives a brief highlight in tabular form how each unit has addressed the various aspects required in the Senior 3 Competence-based Physics Curriculum.
- **1.5: Preparation for teaching and the teaching process-** It highlights importance of planning for teaching, guides the teacher on the actual process of planning, and provides s a sample lesson plan.

**Part 2** provides a **unit-to-unit guide** to the teacher on how to facilitate learners to acquire the knowledge, skills and attitudes envisaged in each unit . This part is therefore structured into units

The main elements of of each unit guide are:

- **Unit heading** – This gives the unit title as stated in the syllabus.
- **Key Unit Competence:** This gives the broad competence which the learner will achieve once he/she has met all the learning objectives stipulated in the unit.
- **Learning Objectives:** This section outlines three categories of syllabus-specified learning objectives that a learner is expected to achieve through his/her interaction with the concepts and activities planned for the unit. These categories are.
  - **Knowledge and understanding:** As in the existing curriculum, Though, knowledge and understanding fall at the lower levels of the Bloom's taxonomy they enhance they enhance learning at the higher levels.
  - **Skills:** It is through the skills that students apply their learning and engage in higher order thinking. These skills relate to the upper levels of Bloom's taxonomy and they lead to deep rather than surface learning.
  - **Attitudes and values:** Truly engaging with the learning requires appropriate attitudes and values that relate to the unit.
- **Prerequisite to the unit:** This section outlines key knowledge,

skills attitudes and values that learners need to have acquired earlier that will facilitate easier acquisition of the new knowledge, skills attitudes and values envisaged in this unit. It also guides the teacher on how to find out that the learners possess them before they start learning the concepts in this unit, and how to help learners in case they do not possess them.

- **Assessment Criteria:** This is meant to evaluate whether learners have succeeded in achieving the Key Unit Competence(s) intended. This section will help the teacher in assessing whether the unit objectives have been met.
- **Crosscutting issues to be addressed in the unit:** The section outlines the specific crosscutting issues that will be addressed by infusion as the learners do the activities and interacts with concepts planned for the unit. This is meant to make the teacher conscious on and be on the look out for suitable opportunities through out the teaching/learning process in the entire unit to address the cited crosscutting issues. This issues will be discussed in detail later in this book
- **Generic competences to be addressed in the unit:** The section outlines the specific generic competences to be acquired by the learners by doing the activities and interacting with concepts planned for the unit. This competences will be discussed in detail later in this book
- **Vocabulary/keywords:** This is a list of new words that the learners will come across and interact with in the unit. The teacher is encouraged to help the learners to understand their meanings and usage in order to help them build their language and vocabulary.

**Guidance on the problem statement:** This section guides the teacher on how to facilitate the learners to do the introductory activity, known as the problem statement, given at the start of the unit in the Learners book. The purpose of the problem statement activity is to challenge and motivate learners to be eager and actively participate in the activities planned for the unit with a drive to get the answers to the problem outlined in the activity.

- **Attention to special needs:** The section guides the teacher on how to handle learners with special needs as they do the learning activities organised in the unit.
- **List of lessons:** This is a list in tabular form of the structuring of the unit into lessons, each with a lesson title and the number of periods allocated to each lesson. Note that the total number of periods must be equal to those allocated to that unit in the syllabus.
- **Lesson development:** This section provides guidance to the teacher on how to facilitate learning in each lesson. The guidance for each lesson is structured as follows:
  - **Lesson title**
  - **Specific objectives** of the lesson
  - **Teaching and learning aids.**
  - **Learning activities:** Under each activity the teacher is guided on how to **conduct** the activity and **facilitate** the **synthesis** of the knowledge being acquired. The **answers to the activities** are also provided here.

- *Assessment of the lesson:* Here, the teacher is guided on how to assess whether learners have acquired the knowledge, skills and attitudes after going through the lesson.
- *Summary of the unit:* This section guides the teacher on how to summarise the main concepts learnt in the unit. It also guides the teacher on how to help the learners determine the solution to the problem statement activity provided at the start of the unit, since by now they have acquired enough knowledge and skills to enable them solve the problem
- *End of unit assessment:* This section guides the teacher on how to assess whether learners have acquired the knowledge, skills and attitudes after going through all the lesson in the unit.
- *Additional information for the teacher:* This section gives the teacher more information than what the syllabus recommends for purposes of enriching his/her knowledge.
- *Remedial activities:* This is a description of the activities that the teacher should give to the slow learners in order to help them to master the concepts.
- *Extended activities:* This is a description of the activities that the teacher should give to the fast learners in order to help advance their mastery the concepts.
- *Answers to all exercises.* This section provides answers to all exercises in the unit, extended and remedial activities in the teacher's guide.

## 1.1.2 Background Information on the new curriculum

The aim of a competence-based curriculum is to develop in the learners competences that will enable them interact with the environment in more practical ways.

It clearly defines the **knowledge, skills** and **attitudes** that the learner should acquire by doing the specified learning activities.

### (a) Types of competences and their acquisition

Competencies are statements of the characteristics that students should demonstrate, which indicate they are prepared and have the ability to perform independently in professional practice. The two types of competencies envisaged in this curriculum are **basic** and **generic** competences.

#### (i) Basic competences

Basic competences are addressed in the stated broad subject competences and in objectives highlighted in each of units of learning.

They include:

#### Literacy

This competency will be acquired by S3 Physics students as they:

- Read and interpret learning activities, and questions in exercises.
- Write down in English their observation and answers to guiding questions given in the activities.
- Listen and communicate their ideas in group and class discussions.

## **Numeracy**

This competency will be acquired by S3 Physics students as they compute and manipulate numbers, symbols, quantities, shapes and figures to accomplish a task involving calculations, measurements, and estimations in units in Units, 2, 5 and 5.

## **ICT and digital competences**

This competency will be acquired by S3 Physics students as they:

- Assess, retrieve and exchange information via internet or cell phones.
- Use information and communication technologies to enhance learning and teaching e.g overhead projector.

## **Citizenship and national identity**

This competency will be acquired by S3 Physics students as they:

- Perform activities outlined in the book, that are based on Rwanda environment and setting.
- As they do activities, interpret information, Physics facts and data derived from Rwanda sources in the problems provided in the book. Unit 4 provides a lot of such information.

## **Entrepreneurship and business development**

This competency will be acquired by S3 Physics students as they do activities and interact with information provided in Units 4, 7 and 8 on energy generation, i.e see the opportunities of making money through use of electricity in production.

## **(ii) Generic competences**

Generic competencies that S3 Physics will acquire in the process of doing activities and learning the concepts planned for S3 Physics include:

### **Critical thinking and problem solving skills:**

The students will acquire this competence

as they use their mind to evaluate science related situations and come with solutions to the problems. All the units in the student's book provide such mind provoking scenarios.

### **Creativity and innovation:**

The students will acquire this competence as they use imagination beyond knowledge provided in classroom to generate new ideas and construct new concepts.

### **Research skills**

The students will acquire this competence as they interrogate sources of information including the Internet, reference books and resource persons to gather information that will help solve real life problems that apply physics concepts.

### **Communication in official languages**

The students will acquire this competence as they read and interpret learning instructions, activities, questions in exercises, and communicate their ideas to others in group and class discussions. All the units in the student's book provide such opportunities to the learner.

### **Cooperation, inter-personal management and life skills**

The students will acquire this competence as they work in groups and cooperate in teams into do the task given in learning activities. They learn to respect the opinions of others and the complementary roles played by people through cooperation.

### **Lifelong learning**

The students will acquire this competence as they continuously learn



to learn i.e continuously discover new ways of getting information through research. This is why they should be exposed to more research activities.

### **(b) Cross-cutting issues to be addressed during learning**

These emerging issues give an indication of some national priorities and hence need to be incorporated in the learning process. The eight cross-cutting issues are:

#### **Peace and Values Education**

Peace is critical for a society to flourish and for every individual to focus on personal achievement and his or her contribution to the success of the nation.

The teacher of S3 Physics need to be in the fore front to educate his /her students on the need for peace and values, for example by encouraging group work in the learners activities and showing the learners ways of solving interpersonal problems that occasionally arise during interactions and discussions.

#### **Financial Education**

Financial education provides the tools for sound financial management practices on earnings, spending, saving, borrowing and investing. Unit 7 in S3 Physics provides the teacher with many opportunities to educate his /her students on financial saving through economical use of energy supplies like electricity.

#### **Standardization Culture**

Standardisation Culture develops learners' understanding of the importance of standards as a pillar of economic development. The S3 Physics teacher should use the opportunities provided by

the various activities and problem setting that involve use of objects with many options to sensitize the students on the importance of acquiring and using standard items.

#### **Environment and sustainability**

A well conserved environment is obviously key to our health and survival. It is therefore important for the S3 Physics teacher to make use of the opportunities that arise in the process of teaching and learning Physics through activities to sensitise learners on the importance of conserving the environment. One way is by ensuring that the learners always dispose off the waste materials at the end of an activity in ways that do not pollute the environment. Units 14 of the student's book provides the learner with opportunities how environmental factors affect plant life.

#### **Gender education**

There is a strong moral imperative to accord every individual their basic human rights. Gender inequality results in women and girls being treated less favourably than men.

The S3 Physics teacher should make use of the opportunities and situations that arise in the classroom to educate students on the need for equal treatment of both genders. A good example is ensuring that discussion groups have a balanced number of boys and girls.

#### **Comprehensive sexuality education (HIV/AIDS, STI, Family planning, Gender equality and reproductive health)**

Few young people receive adequate preparations for their sexual lives. This leaves them potentially vulnerable to coercion, abuse and exploitation, unwanted pregnancies and sexually

transmitted infections (STIs) including HIV/AIDS.

The S3 Physics teacher should use the opportunities provided in the student's book by the content highlighting sexuality and HIV facts to educate learners on these aspects

### **Inclusive Education**

Inclusive education refers to ensuring all learners regardless of gender or ability/inability are engaged in education to help them realise their potential. To achieve this, the S3 Physics teacher should plan the teaching/learning resources and activities in ways that give all learners a chance to participate in the learning.

### **(c) Special needs education and inclusivity**

All Rwandans have the right to access education regardless of their different needs. The provision allow all citizens to benefit from all educational programs. This necessitates the focus on special needs education. The critical issue is that we have persons/ learners who are very different in their ways of living and learning as opposed to the majority. The difference can either be emotional, Physical, sensory and intellectual learning challenges traditionally known as mental retardation. These learners equally have the right to benefit from the free and compulsory basic education. Therefore, the schools' role is to enrol them and set strategies to provide relevant education to them. The teacher therefore is required to consider each learner's needs during teaching and learning process. Assessment strategies and conditions should also be tailored to the needs of these learners. Also, the teacher should include learners with special educational needs in classroom activities as much as possible.

The special needs in learners fall in any of the following common categories:

- Physical difficulties
- Visual difficulties
- Hearing difficulties
- Mental difficulties
- Genocide traumatized learners

The teacher should identify such cases and help facilitate the affected learners in learning. For example, learners with visual and hearing difficulties should sit near the teacher's table for easy supervision and assistance. The following are some suggestions on how to support special needs children in your class.

### **(i) Learners with Physical challenges**

These are learners, whose some of the body parts are not able to function normally due to Physical problems. For example, some learners have partial or total incapacitation in the use of some limbs or hands. In such cases, the learners will need assistance during activities that involve movement. This could be during a nature walk and other activities that learners have to stand for some reason. The teacher should organize for the learner's ease of movement. The learner should also be given time to catch up with the others.

In case the hands are affected, the learners should be given more time to finish their work. In both cases, the learners should not be pressurized to do things that can cause injury or ridicule.

### **(ii) Learners with visual challenges**

These learners have problems with their eyesight. They may be longsighted, shortsighted or have some eye sicknesses. They should sit at a position where they are able to see the chalkboard without straining.

The material to be observed should be brought to appropriate location where these learners can be able to see. The magnifying glasses can be used where necessary. The teacher should use large diagrams, charts and labels. In some cases, the learners can be allowed to touch and feel whatever they are looking at.

The teacher should read aloud most of the things he/she writes on the chalkboard. Other learners can also assist by reading aloud. The lighting system in the classroom can also be improved.

### **(iii) Learners with hearing challenges**

The affected part in this case is the ear. The learner can have **hearing aids**. The teacher should use as many visual aids as possible. They should also project their voice and always talk while facing the learners. Use of gestures and signs while talking helps the learner figure out what the teacher is saying as well.

### **(iv) Learners with speech challenges**

One of the most speech challenges is stammering. Such learners speak with many difficulties. The teacher should be patient with them and encourage such learners to express themselves in their own way. Such learners should be given more written exercises.

### **(v) Learners with mental challenges**

The teacher should identify the nature and level of the mental difficulty with such learners. Such learners should then be given special assistance and attention at individual levels. They can be given special tests or assessments.

In general, all the learners with difficulties should be well facilitated. This encourages and motivates them. The teacher and the rest of the class should never ridicule learners with any of the difficulties. Note that generally, the people with any kind of disability can be very sensitive to any kind of negative comments or criticism.

*Remind them that '**Disability is not inability**'.*

Treat them fairly but not with undue favours.

## I.2: Effective teaching and learning of S3 Physics

### 1.2.1 Teacher's and learner's roles for effective teaching/ learning of S3 Physics

#### (a) Teacher's role and basic skills

The teacher is the most important resources for an effective Physics lesson

Some of the key roles of the S3 Physics teacher include:

- Organising the classroom to create a suitable learning environment.
- Preparing appropriate materials for learning activities.
- Encouraging and accepting student autonomy and initiative.
- Using raw data and primary sources, along with manipulative, interactive, and Physical materials.
- Using cognitive terminology such as classify, analyse, predict, and create when framing tasks.
- Allowing student responses to drive lessons, shift instructional strategies,.
- Familiarizing themselves with students' understandings of concepts before sharing their own understandings of those concepts.
- Encouraging students to engage in dialogue, both with the teacher and one another.
- Engaging students in experiences that pose contradictions to their initial hypotheses and then encouraging discussion.
- Providing time for students to construct relationships and create metaphors.
- Engaging students in variety of learning activities.

- Using a variety of teaching and assessment methods.
- Adjusting instructions to the level of the learner.
- Nurturing students' natural curiosity.
- Motivating learners to make them ready for learning.
- Coordinate learners' activities so that the desired objectives can be achieved.
- Assessing learners' activities and suggest solutions to their problems.
- Assist learners to consolidate their activities by summarising the key points learnt.

Some of the key **skills** that the S3 Physics teacher should have include:

- Creativity and innovation.
- Makes connections/relations with other subjects.
- A high level of knowledge of the content.
- Effective disciplining skills manage adequately the classroom
- Good communicator.
- Guidance and counselling.

#### (b) Learner's role in learning Physics

Learning takes place only when the learner acquires the intended knowledge, skills and attitudes. As such, learning is a highly personal and individual process. Thus, a learner must be actively engaged in the learning exercise.

For active participation in learning, the learner should:

- Raise questions about what is observed.
- Suggest solutions to the problems observed.
- Take part in planning investigations with appropriate controls to answer specific questions.
- Carry out investigations to search for answers with the help of materials in search of patterns and relationships while looking for solutions to problems.
- Working collaboratively with others, communicating their own ideas and considering others' ideas.
- Expressing themselves using appropriate Physics terms and representations in writing and talk.
- Engaging in lively public discussions in defence of their work and explanations.
- Applying their learning in real-life contexts.
- Reflecting critically about the processes and outcomes of their inquiries.

### 1.2.2: Teaching/learning resources

These refer to things that the teacher requires during the teaching process. They include:

- The classroom
- Textbooks
- Wall charts and wall maps
- Materials and apparatus
- Various tools and equipment
- Physics models
- Resource persons
- Firms such as hydroelectric power stations, engineering firms among others

### (a) Classroom as a learning environment

A Classroom generally refers to the place where learning takes place. Learners learn from everything that happens around them, such as the things that they hear, see, touch, taste, smell and play with.

#### Classroom organization

It is important for the teacher to make the classroom an attractive and stimulating environment. This can be done by:

- Carefully arranging the furniture in the classroom in an organised way. to allow free movement of learners and the teacher.
- Putting up learning and teaching aids on the walls. Examples are wall charts, pictures and photographs.
- Displaying teaching models.
- Providing objects for play for example toys.
- Having a display corner in the classroom where learners display their work.
- Setting a corner for storing materials so as not to obstruct learners or distract them.
- Spreading out the learners evenly so that they do not interfere with one another's activities.
- Setting up the materials for the series of lessons or activities going on for a number of days or weeks in a location where they do not interfere with other daily activities
- Organizing the sitting arrangement such that learners face the lighted areas of the room.
- Choosing the most appropriate location for the teacher and the



chalkboard such that they are visible to all learners and the teacher has a good view of all learners in the class.

## **(b) Apparatus and materials**

For learners to study Physics through the activity method, a number of materials and apparatus are required. The important role played by materials in learning has been felt for centuries. This is noted for instance in the old Chinese proverb that says:

- *When I hear I forget*
- *When I see I remember*
- *When I do I understand*

Since Physics is largely a practical subject, materials help the teacher to convey his/her points, information or develop skills, simply and clearly, and to achieve desired results much faster.

Some of the materials that a teacher requires for Physics activities and calculations can be collected from the local environment.

Many others can be improvised while some have to be purchased. Whether collected, improvised or purchased, there are certain materials that are valuable to have around almost all the time.

These include:

### **(i) Science Kit**

A science kit is a special box containing materials, apparatus and equipment necessary to conduct an array of experiments. The content of the physics kit depends on the curriculum requirements per level. Most science kits are commercially available and target particular levels of learners. However, the teacher is encouraged to come up with a kit based on the syllabus requirement

### **(ii) Models**

A model refers to a three-dimensional representation of an object and is usually much smaller than the object. Several models are available commercially in shops. Examples of Physics models include models of electric motors, hydraulic systems among others. These can be purchased by schools for use during Physics activities.

### **(iii) Resource persons**

A resource person refers to anybody with better knowledge on a given topic area. Examples include health practitioners such as doctors, nurses and laboratory technologists, agricultural extension officers, environmental specialists among others. Depending on the topic under discussion, the teacher can organize to invite a resource person in that area to talk to learners about the topic. The learners should be encouraged to ask as many questions as possible to help clarify areas where they have problems.

### **(iv) Improvisation**

If each learner is to have a chance of experimenting, cheap resources must be made available. Complicated apparatus may not always be available in most schools. Such sophisticated equipment made by commercial manufacturers are usually expensive and majority of schools cannot afford them. The teacher is therefore advised to improvise using locally available materials as much as possible.

#### (vi) Scheduling learning activities and venues

Some of the activities suggested in the student's good planning and scheduling in order to get accurate results. An example is observing some effects of environmental factors on plant growth illustrated in unit 14. The teacher should therefore think ahead while making the scheme of work so that the prevailing weather pattern and the most appropriate timing are considered..

### 1.2.3 Grouping learners for learning

Most of the Physics activities suggested in the student's book are carried out in groups and therefore the teacher should place 2 or 3 desks against each other and then have a group of learners sitting around those desks.

In certain activities, the teacher may wish to carry out a demonstration. In this case, the learners should be sitting or standing in a semicircle, or arranged around an empty shape of letter "U" such that each learner can see what the teacher is doing clearly and without obstruction or pushing. If the learners are involved in individual work, each learner can work on the floor or on the desk or a portion of the desk if they are sharing. In this case, they need not face each other.

Grouping learners for learning has increasingly become popular in recent years. In fact, the shift from knowledge-based to competence curriculum will make grouping the norm in the teaching process. Grouping learners can be formed by one or all of the following:

- a. Similar ability grouping.
- b. Mixed ability grouping.
- c. Similar interests grouping.
- d. Needs grouping.

- e. Friendship grouping.
- f. Sex-based grouping.

Grouping learners in a Physics class has several advantages that include:

- a. The individual learner's progress and needs can easily be observed.
- b. The teacher-learner relationship is enhanced.
- c. A teacher can easily attend to the needs and problems of a small group.
- d. Materials that were inadequate for individual work can now be easily shared.
- e. Learners can learn from one another.
- f. Cooperation among learners can easily be developed.
- g. Many learners accept correction from the teacher more readily and without feeling humiliated when they are in a small group rather than the whole class.
- h. Learners' creativity, responsibility and leadership skills can easily be developed.
- i. Learners can work at their own pace.

The type of "grouping" that a teacher may choose depends on:

- a. The topic or task to be tackled.
- b. The materials available.
- c. Ability of learners in the class (fast, average, slow).

However, the teacher must be flexible enough to adjust or change his/her type of grouping to cope with new situations.

There is no fixed number of learners that a group must have. This again will be dictated by such factors as the task to be done, the materials, characteristics of learners in your class, size and the space

available. However, groups should on average have between four to five learners. You can also resort to pair work depending on the nature of the content being taught at the time.

There is no one method or approach to teaching that is appropriate to all lessons. A teacher should, therefore, choose wisely the method to use or a combination of methods depending on the nature of the topic or subtopic at hand.

### 1.2.4: Teaching methods

There is a variety of possible methods in which a teacher can help the learners to learn. These include :

- (a) Direct exposition
- (b) Discovery or practical activity
- (c) Group, class or pair discussion
- (d) Project method
- (e) Educational visit/ field trips
- (f) Teacher demonstration
- (g) Experimentation/ Research

The particular technique that a teacher may choose to use is influenced by several factors such as:

- The particular group of learners in the class.
- The skills, attitudes and knowledge to be learned.
- Learning and teaching aids available. The local environment.
- The teacher's personal preference.
- The prevailing weather.
- The requirements of Physics syllabus.

#### (a) Direct exposition

This is the traditional way of teaching whereby the teacher explains something while the learners listen. After the teacher

has finished, the learners may ask questions. However, in a competence-based curriculum, this technique should be used very minimally.

#### (b) Guided Discovery

In this technique, the teacher encourages learners to find out answers to problems by themselves. The teacher does this by:

- Giving learners specific tasks to do.
- Giving learners materials to work with.
- Asking structured or guided questions that lead learners to the desired outcome.

Sometimes learners are given a problem to solve and then left to work in an open-ended manner until they find out for themselves.

This is the most preferred method of teaching in the implementation of competency based curriculum.

#### (c) Group/class discussion or pair work

In this technique, the teacher and learners interact through question and answer sessions most of the time. The teacher carefully selects his/her questions so that learners are prompted to think and express their ideas freely, but along a desired line of thought. The method leads learners from the known to unknown in a logical sequence; and works well with small groups. The method boosts confidence in learners and improve interpersonal and communication skills.

The main disadvantage of this method is that some learners maybe shy or afraid to air their opinions freely in



front of the teacher or their peers. It may give them more confident learners a chance to dominate the others.

#### **(d) Project method**

In this approach, the teacher organizes and guides a group of learners or the whole class to undertake a comprehensive study of something in real life over a period of time such as a week or several weeks.

Learners using the project method of studying encounter real life problems which cannot be realistically brought into a normal classroom situation. A project captures learners' enthusiasm, stimulates their initiative and encourages independent enquiry. The teacher, using the project method, must ensure that the learners understand the problem to be solved and then provides them with the necessary materials and guidance to enable them carry out the study.

The main disadvantage of this method is that if a project is not closely supervised, learners easily get distracted and therefore lose track of the main objective of their study. Studying by the project method does not work well with learners who have little or no initiative.

#### **(e) Educational visits and trips/ nature walks**

This is a lesson conducted outside the school compound during which a teacher and the learners visit a place relevant to their topic of study. An educational visit/nature walk enables learners to view their surroundings with a broader outlook that cannot be acquired in a classroom setting. It also

allows them to learn practically through first-hand experience. In all "educational visit/nature walk lessons", learners are likely to be highly motivated and the teacher should exploit this in ensuring effective learning. However, educational visits are time consuming and require a lot of prior preparation for them to succeed. They can also be expensive to undertake especially when learners have to travel far from the school.

#### **(f) Demonstration lessons**

In a demonstration, the teacher shows the learners an experiment, an activity or a procedure to be followed when investigating or explaining a particular problem. The learners gather around the teacher where each learner can observe what the teacher is doing. It is necessary to involve the learners in a demonstration, for example by:

- Asking a few learners to assist you in setting up the activity.
- Requesting them to make observations.
- Asking them questions as you progress with the demonstration.

This will help to prevent the demonstration from becoming too teacher-centred.

#### **When is a demonstration necessary?**

A teacher may have to use a demonstration, for example when:

- The experiment/procedure is too advanced for learners to perform.
- The experiment/ procedure is dangerous.
- The apparatus and materials involved are delicate for learners to handle.
- Apparatus and equipment are too few.

### 3. Content Maps

	UNIT 1: Graphs of linear motion	UNIT 2: Friction force and Newton's laws of motion	UNIT 3: Applications of atmospheric pressure	UNIT 4: Renewable and non-renewable energy sources	UNIT 5 Heat transfer and quantity of heat
<b>Number of periods</b>	8	10	10	10	9
<b>Key Unit Competence</b>	By the end of this unit of linear motion learner should be able to plot and analyse the graphs.	By the end of this unit learner should be able to perform experiments involving Newton's laws of motion and friction force	By the end of the unit the learner should be able to explain the existence of pressure in gas and the application of atmospheric pressure.	By the end of this unit, the learner should be able to differentiate between renewable and non-renewable sources and give examples.	By the end of the unit the learner should be able to evaluate modes of heat transfer and determine specific heat capacity of metal block.
<b>Number of Lessons</b>	4	8	5	10	9
<b>Equipment/ Learning/ Teaching Materials Required</b>	<ul style="list-style-type: none"> <li>• Ticker timer</li> <li>• Dynamic trolley</li> <li>• Graph papers</li> <li>• Football</li> <li>• Circular dish</li> <li>• Cello tape</li> </ul>	<ul style="list-style-type: none"> <li>• Football, balloon</li> <li>• Playing field, smooth and rough surface</li> <li>• Table/bench</li> <li>• Ticker timer, tape, carbon paper</li> </ul>	<ul style="list-style-type: none"> <li>• Drinking glass, beakers</li> <li>• Straw, tubes, cork, flexible pipe</li> <li>• Water</li> <li>• Thin-wall can</li> </ul>	<ul style="list-style-type: none"> <li>• Charts (manila paper)</li> <li>• Convex lens</li> <li>• Paper</li> <li>• Scissor</li> <li>• Sewing thread</li> <li>• Light weight basket</li> <li>• Small trash bag</li> <li>• Clamp and stand</li> <li>• String</li> <li>• Pendulum bob</li> <li>• Calculator</li> <li>• Weighing scale</li> <li>• Safety pins</li> <li>• Nails (screws)</li> <li>• Battery holder</li> <li>• Wood block</li> </ul>	<ul style="list-style-type: none"> <li>• Measuring cylinder</li> <li>• Beakers</li> <li>• Heat tubes</li> <li>• Covering oil</li> <li>• Wax</li> <li>• Source of heat</li> <li>• Thermometer</li> <li>• Metal rods</li> <li>• Candle</li> <li>• Dull &amp; shiny plates</li> <li>• Internet</li> <li>• Student books</li> </ul>

	<ul style="list-style-type: none"> <li>• Runway</li> <li>• Carbon disc</li> <li>• A long tape</li> <li>• Wooden block</li> <li>• Geometrical set</li> </ul>	<ul style="list-style-type: none"> <li>• Coin, marbles, cork</li> <li>• Hammer, masses, spring balance</li> <li>• Nails, pins, straw,</li> <li>• Wooden block, cardboard</li> <li>• Internet, Reference books</li> </ul>	<ul style="list-style-type: none"> <li>• Coin</li> <li>• Mercury barometer,</li> <li>• Syringe, rubber sucker</li> <li>• Internet, reference books</li> </ul>	<ul style="list-style-type: none"> <li>• Disk magnet</li> <li>• Galvanometer</li> <li>• Connecting wires</li> <li>• Bar magnet</li> <li>• Insulated copper wire</li> <li>• Wire</li> <li>• Scotch tape</li> <li>• Student's Book</li> </ul>	<ul style="list-style-type: none"> <li>• Vacuum flask</li> <li>• Weighting machine</li> <li>• Abas &amp; gauge apparatus</li> <li>• Bimetallic</li> <li>• Ball&amp; ring apparatus</li> <li>• Round bottom flask</li> <li>• Calorimeter</li> <li>• Electric circuit (heater)</li> <li>• Stopwatch</li> </ul>
<b>Activities/ Techniques</b>	Students to use group work to carryout Activities 1.1 –1.5	Students to use group work to carryout Activities 2.1 – 2.10	Students to use group work to carryout Activities 3.1 –3.6	Students to use group work to carryout Activities 4.1 – 4.12	Students to use group work to carryout Activities 5.1 – 5.30
<b>Generic Competences Practiced</b>	<ul style="list-style-type: none"> <li>• Creativity and innovation: Nearly all the activities in this unit requires the creativity and innovativeness of the learner in creating, modifying and importing data to draw graphs of linear motion.</li> </ul>	<ul style="list-style-type: none"> <li>• Creativity and innovation: Most activities in this unit require creativity and innovativeness of the learner in demonstrating and explaining the Newton's laws and come up with an application in our daily lives.</li> <li>• Communication skills: Most of the activities in this unit require the student discussions and presentations. Every time the student participates in a discussion or presents</li> </ul>	<ul style="list-style-type: none"> <li>• Creativity and innovation: Nearly all the activities in this unit require the creativity and innovativeness of the learner in demonstrating the existence of atmospheric pressure and applying the concept of atmospheric pressure in an innovative manner.</li> <li>• Communication skills: Most of the activities in this unit require group discussions and presentations.</li> </ul>	<ul style="list-style-type: none"> <li>• Creativity and innovation: Most activities in this unit require creativity and innovativeness of the learner in downloading, installing and configuring application and utility software.</li> <li>• Communication skills: Most of the activities in this unit require the student discussions and presentations.</li> </ul>	<ul style="list-style-type: none"> <li>• Creativity and innovation: With the skills and knowledge of heat transfer, how can you minimize hit and gain loss in devices that use heat energy in their mode of operation e.g. amplifiers are very expensive and on other ways they get damaged in lack of good method of heat loss.</li> <li>• Communication skills: Most of the activities in this unit require group discussions and presentations. Every time the student participates in a discussion or presents findings to the class, his/her communication skills are enhanced.</li> </ul>

	<ul style="list-style-type: none"> <li>Communication skills: Most of the activities in this unit require group discussions and presentations. Every time the student participates in a discussion or presents findings to the class, his/her communication skills are enhanced.</li> <li>Entrepreneurship and business development: The hierarchical charts of Figure 1.7 in Activity 1.5 provide an organogram that represents management structure in a typical business organization.</li> </ul>	<p>findings to the class, his/her communication skills are enhanced.</p> <ul style="list-style-type: none"> <li>Entrepreneurship and business development: Demonstrating the action and reaction force using the person in the boat has business element either the boat is used for fishing or tourist uses it as mean of transportation. Fig. 2.2 uses of coins to demonstrate atmospheric pressure. Money is one of the main factors that determine the start and growth of a business.</li> <li>Citizenship and national identity: To foster citizenship and national identity, most of the content, assessments and activities in this unit are contextualized to fit into Rwanda tenets that promote a sense of cultural heritage.</li> </ul>	<p>Every time the student participates in a discussion or presents findings to the class, his/her communication skills are enhanced.</p> <ul style="list-style-type: none"> <li>Entrepreneurship and business development: Activity 3.3 uses coin to demonstrate atmospheric pressure. Money is one of the main factors that determine the start and growth of a business.</li> <li>Citizenship and national identity: To foster citizenship and national identity, most of the content, assessments and activities in this unit are contextualized to fit into Rwanda tenets that promote a sense of cultural heritage, national identity and patriotism.</li> </ul>	<p>Every time the student participates in a discussion or presents findings to the class, his/her communication skills are enhanced.</p> <ul style="list-style-type: none"> <li>Entrepreneurship and business development: teaching the learners on the best forms of energy sources and giving them alternative options teaches them how to save</li> <li>Citizenship and national identity: To foster citizenship and national identity, most of the content, assessments and activities in this unit are contextualized to fit into Rwanda tenets that promote a sense of cultural heritage, national identity and patriotism.</li> </ul>	<ul style="list-style-type: none"> <li>Citizenship and national identity: To foster citizenship and national identity, most of the content, assessments and activities in this unit are contextualized to fit into Rwanda national identity that promotes a sense of cultural heritage and patriotism. Problem solving: Problem solving In heat transfer most of the activities are such that students are encouraged to find solution in their daily activities in life. In exercise a deliberate effort is made to train the learners in problem solving.</li> </ul>
--	---	---	---	--	--

	<ul style="list-style-type: none"> <li>• Citizenship and national identity: To foster citizenship and national identity, most of the content, assessments and activities in this unit are contextualized to fit into Rwanda tenets that promote a sense of cultural heritage, national identity and patriotism.</li> <li>• Problem solving: The students are to plot and analyse the linear motion. Motion is very important as a means to move from one point to another, when student draw and analyses linear motion, they are made in situations</li> </ul>	<p>national identity and patriotism.</p> <ul style="list-style-type: none"> <li>• Problem solving: The problem statement, activities and assessment questions require the students to brainstorm hence developing their mental ability to select the right tools and procedure for solving a particular problem.</li> </ul>	<ul style="list-style-type: none"> <li>• Problem solving: The problem statement, activities and assessment questions require the students to brainstorm hence developing their mental ability to select the right tools and procedure for solving a particular problem.</li> </ul>	<ul style="list-style-type: none"> <li>• Problem solving: The problem statement, activities and most exercises require the students to brainstorm which is crucial in developing their mental ability to select the right tools and procedure for solving a problem.</li> </ul>	
--	---	---	--	---	--

	<p>and can predict what happen to body that move under the influence of gravity, exercise on problem solving have been suggested in this unit.</p>	<p>demonstrate the law of inertia. Students require a good business idea plus money (capital) to start the business.</p> <ul style="list-style-type: none"> <li>• Citizenship and national identity: To foster citizenship and national identity, most of the content, assessments and activities in this unit are contextualized to fit into Rwanda tenets that promote a sense of cultural heritage, national identity and patriotism.</li> <li>• Problem solving: The problem statement, activities and most exercises require the students to brainstorm which is crucial in developing their mental ability to select the right tools and procedure for solving a problem.</li> </ul>			
--	--	--	--	--	--

<p><b>Cross-cutting issues Addressed</b></p>	<ul style="list-style-type: none"> <li>Environment and sustainability: At some point in the unit, the motion of a car is considered. Combustion of petrol in car produced carbon dioxide and other gases as waste product that contributes to air pollution .</li> <li>Standardisation Culture: Using genuine of genuine football among other equipment used in the unit is emphasised.</li> <li>Inclusive education: Most of the activities in this unit are designed in a way that they encourage inclusivity in education regardless of gender, cognitive or physical disability.</li> </ul>	<ul style="list-style-type: none"> <li>Environment and sustainability: Since the unit will involve use of materials such as straws, balloons among others in doing the activities, it calls for students to be responsible in disposing waste to avoid polluting the environment.</li> <li>Standardisation Culture: The unit involves use of items such as football, carbon papers and spring balance in different activities. These items should be original one. Promoting the standardisation culture in the students.</li> <li>Inclusive education: All the activities in this unit are designed in a way that they encourage inclusivity in education regardless of gender, cognitive or physical disability.</li> </ul>	<ul style="list-style-type: none"> <li>Environment and sustainability: Since the unit will involve use of materials such as cardboard, straws, pipes, syringe, plastic containers among others, it require learners to be responsible in the disposal of the waste product to avoid polluting the environment. Moreover, the use of water in the unit, the water is scarce resource and it call for learners to avoid wasting and polluting water sources.</li> <li>Standardisation Culture: The use of mercury barometer, a picture of aneroid and Fortin barometer and vacuum cleaner require learners to always go for genuine items when purchasing. Cheap is expensive!</li> </ul>	<ul style="list-style-type: none"> <li>Environment and sustainability: Since the unit will involve talking about good and bad energy sources in that being good or bad is determined by how they affect the environment, its better to sensitise them about how to protect the environment.</li> <li>Inclusive education: All the activities in this unit are designed in a way that they encourage inclusivity in education regardless of gender, cognitive or physical disability.</li> <li>Gender: the content in the unit takes care of the gender balance</li> </ul>	<ul style="list-style-type: none"> <li>Standardisation Culture: Use of genuine equipment such vacuum flask saucapan among others within the unit has been emphasis.</li> <li>Inclusive education: Most of the activities in this unit are designed in a way that they encourage inclusivity in education regardless of gender, cognitive or physical disability.</li> <li>Gender: The content in this unit balances on gender by using information that applies to both male and female.</li> </ul>
--	---	---	---	---	---

	<ul style="list-style-type: none"> <li>Gender: The content in this unit balances on gender by using information that applies to both male and female. The content is also represented using neutral words. The words like boy, girl, man and woman are avoided.</li> </ul>	<ul style="list-style-type: none"> <li>Gender: Where necessary, the content provided in the unit balances on gender by making sure both male and female are represented using neutral words.</li> </ul>	<ul style="list-style-type: none"> <li>Inclusive education: Most of the activities in this unit are designed in a way that they encourage inclusivity in education regardless of gender, cognitive or physical disability.</li> <li>Gender: Where necessary, the content provided in the unit balances on gender by making sure both male and female are represented using neutral words. Words like girl, boys, man and woman are avoided.</li> </ul>		
<b>Assessment Strategies of Key Unit competence</b>	<ul style="list-style-type: none"> <li>Pre-emptive problem statement at the beginning of the Unit</li> <li>Practical Activities 1.1 – 1.5</li> <li>Assessment exercise at the end of each lesson.</li> <li>Unit test 1 question at the end of the Unit.</li> </ul>	<ul style="list-style-type: none"> <li>Pre-emptive problem statement at the beginning of the Unit</li> <li>Practical Activities 2.1 – 2.10</li> <li>Assessment exercise at the end of each lesson</li> <li>Unit test 2 questions at the end of the Unit.</li> </ul>	<ul style="list-style-type: none"> <li>Pre-emptive problem statement at the beginning of the Unit</li> <li>Practical Activities 3.1 – 3.6.</li> <li>Assessment exercise at the end of each lesson</li> <li>Unit test 3 questions at the end of the Unit.</li> </ul>	<ul style="list-style-type: none"> <li>Pre-emptive problem statement at the beginning of the Unit</li> <li>Practical Activities 4.1 – 4. 12</li> <li>Assessment exercise at the end of each lesson</li> <li>Revision questions at the end of the Unit</li> </ul>	<ul style="list-style-type: none"> <li>Pre-emptive problem statement at the beginning of the Unit</li> <li>Practical Activities 5.1 – 5.30</li> <li>Assessment exercise at the end of each lesson</li> <li>Unit test 5 questions at the end of the Unit.</li> </ul>



	UNIT 6: Laws of thermodynamics	UNIT 7 Introduction to Electromagnetic induction	UNIT 8: Electrical power transmission	UNIT 9 Electric field intensity	UNIT 10: House electric installation
<b>Number of periods</b>	9	9	10	9	12
	By the end of this unit, the learner should be able to describe the internal energy of a system by applying laws of thermodynamics.	By the end of this unit the learner should be able to apply the principle of electromagnetic induction.	By the end of the unit the learner should be able to analyse the transmission of electrical power	By the end of this unit, the learner should be able to calculate intensity of electric field due to one or more point charges.	By the end of the unit the learner should be able to analyse and carry out a simple electric installation
<b>Number of Lessons</b>	9	4	7	9	4
<b>Equipment/ Learning/ Teaching Materials Required</b>	<ul style="list-style-type: none"> <li>• Water</li> <li>• Beakers</li> <li>• Thermometer</li> <li>• Bunsen burner</li> <li>• Solid ice</li> <li>• Marbles of different colours</li> <li>• Transparent container</li> <li>• Fruits</li> <li>• Salt</li> </ul>	<ul style="list-style-type: none"> <li>• Magnet</li> <li>• Insulators copper wire</li> <li>• Dry cells</li> <li>• Centre zero galvanometer</li> <li>• Soft iron rod</li> <li>• AC source</li> </ul>	<ul style="list-style-type: none"> <li>• Transformer</li> <li>• Galvanometer, soft iron sheet</li> <li>• Insulated copper wire, connecting wire</li> <li>• Switch, masking tape</li> <li>• Internet, reference books</li> <li>• Source of current</li> <li>• Cables of different thickness</li> <li>• Sheet of paper,</li> </ul>	<ul style="list-style-type: none"> <li>• Student's Book</li> <li>• internet</li> <li>• Polythene rods</li> <li>• Stand</li> <li>• Clamp</li> <li>• Thread</li> <li>• Glass dish</li> <li>• Castor oil</li> <li>• Electrodes</li> <li>• Connecting wires</li> <li>• Grass seeds</li> <li>• Rubber cork</li> <li>• Straws</li> <li>• Tissue paper</li> </ul>	<ul style="list-style-type: none"> <li>• Manila paper</li> <li>• Geometrical set</li> <li>• Fuses</li> <li>• Socket</li> <li>• Switch</li> <li>• Bulb</li> <li>• Internet, reference books</li> <li>• Chart showing standard symbol of electrical installation</li> <li>• Electrical lamps</li> <li>• Electrical cables</li> <li>• Chart showing domestic wiring system.</li> <li>• Premise with lightning protection system</li> </ul>

	<ul style="list-style-type: none"> <li>• Potatoes</li> <li>• Sugar</li> <li>• Soap</li> <li>• Clothes</li> <li>• Ice burner</li> <li>• Tripod stand</li> <li>• Wire gauze</li> <li>• Stirrer</li> <li>• Ether</li> <li>• Stop clock/watch</li> <li>• Coins</li> <li>• Cement blocks</li> <li>• Copper wire</li> <li>• Student's Book</li> </ul>			<ul style="list-style-type: none"> <li>• Test tubes</li> <li>• Metallic pipe</li> <li>• Plastic eraser</li> <li>• Pith ball</li> </ul>	
<b>Activities/ Techniques</b>	Students to use group work to carryout Activities 6.1 –6.11	Students to use group work to carryout Activities 7.1 – 712	Students to use group work to carryout Activities 8.1 – 8.8.	Students to use group work to carryout Activities 9.1 – 9.8	Students to use group work to carryout Activities 10.1 – 10.9
<b>Generic Competences Practiced</b>	<ul style="list-style-type: none"> <li>• Creativity and innovation: Activities in this unit requires the creativity and innovativeness of the learner in creating, modifying and importing charts and graphics.</li> <li>• Communication skills: The activities have most of the discussions and</li> </ul>	<ul style="list-style-type: none"> <li>• Creativity and innovation: The concepts discussed in the unit will help learners in projects like how to use the principle of electromagnetic and hence how to make a welding machine promote innovation.</li> </ul>	<ul style="list-style-type: none"> <li>• Creativity and innovation: Nearly all the activities in this unit requires the creativity and innovativeness of the learner in making a simple transformer as project work at the end of unit before summary.</li> <li>• Communication skills: Most of the activities in this unit require group discussions and presentations. Every time the</li> </ul>	<ul style="list-style-type: none"> <li>• Creativity and innovation: the activities require the learners to come up with answers.</li> <li>• Communication skills: In this unit, the activities in this unit require the student discussions and presentations. Every time the student participates in a discussion or presents</li> </ul>	<ul style="list-style-type: none"> <li>• Creativity and innovation: Most activities in this unit require creativity and innovativeness of the learner in discussing critically how to carry out domestic electrical installation without endangering our lives and come up with new method of doing domestic wiring in houses.</li> </ul>

	<p>presentations. Every time the student participates in a discussion or presents findings to the class, his/her communication skills are enhanced.</p> <ul style="list-style-type: none"> <li>• Problem solving: The problem statement, activities and assessment questions require the students to brainstorm hence developing their mental ability to select the right tools and procedure for solving a particular problem.</li> </ul>	<ul style="list-style-type: none"> <li>• Communication skills: Most of the activities in this unit require the student discussions and presentations. Every time the student participates in a discussion or presents findings to the class, his/her communication skills are enhanced.</li> <li>• Entrepreneurship and business development: Use of motors to come up with a business idea such as the car wash using a motor machine among others.</li> <li>• Citizenship and national identity: To foster citizenship and national identity, most of the content, assessments and activities in this unit are contextualized to fit into Rwanda tenets that promote a sense of cultural heritage, national identity and patriotism.</li> </ul>	<p>student participates in a discussion or presents findings to the class, his/her communication skills are enhanced.</p> <ul style="list-style-type: none"> <li>• Entrepreneurship and business development: The picture in figure 8.11 and the diagram in Figure 8.14 provide a good example of entrepreneurship and business development because it demonstrates how electricity is transmitted to business places thus giving learners an idea of one of the things they may require when starting a business.</li> <li>• Citizenship and national identity: To foster citizenship and national identity, most of the content, assessments and activities in this unit are contextualized to fit into Rwanda national identity that promotes a sense of cultural heritage and patriotism.</li> </ul>	<p>findings to the class, his/her communication skills are enhanced.</p> <ul style="list-style-type: none"> <li>• Problem solving: The problem statement, activities and most exercises require the students to brainstorm which is crucial in developing their mental ability to select the right tools and procedure for solving a problem</li> </ul>	<ul style="list-style-type: none"> <li>• Communication skills: Most of the activities in this unit require the student discussions and presentations. Every time the student participates in a discussion or presents findings to the class, his/her communication skills are enhanced.</li> <li>• Entrepreneurship and business development: The unit has given a wide discussion on electrical installation and lightning arrester. This is important for the learners since it will call for them to do electrical installation on the premises they want to do their business from and also install lightning arrester. Lightning is one of the natural factors that can contribute to the losses in the business, if the premise you are working from is severely stroke by it.</li> </ul>
--	--	---	--	---	---

	<ul style="list-style-type: none"> <li>• Problem solving: In electromagnetic induction the main problem is to use magnets and motion to produce e.m.f. This is to overcome reliance to cells and batteries in transformer the idea of power overcoming problem in power transmission.</li> </ul>		<ul style="list-style-type: none"> <li>• Problem solving: The problem statement, activities and assessment questions in this unit require students to brainstorm hence developing their mental ability to select the right tools and procedure for solving a problem.</li> </ul>		<ul style="list-style-type: none"> <li>• Citizenship and national identity: To foster citizenship and national identity, most of the content, assessments and activities in this unit are contextualized to fit into Rwanda tenets that promote a sense of cultural heritage, national identity and patriotism.</li> <li>• Problem solving: The problem statement, activities and most exercises require the students to brainstorm which is crucial in developing their mental ability to select the right tools and procedure for solving a problem.</li> </ul>
--	--	--	--	--	---

<p><b>Cross-cutting issues Addressed</b></p>	<ul style="list-style-type: none"> <li>Inclusive education: Most of the activities in this unit are designed in a way that they encourage inclusivity in education regardless of gender, cognitive or physical disability.</li> <li>Gender: The content in this unit takes care of gender balance.</li> </ul>	<ul style="list-style-type: none"> <li>Environment and sustainability: Since the unit will involve discussion of transformers, the students are sensitised to take care of oil that leaks in transformer to avoid polluting the environment.</li> <li>Standardisation Culture: Since the unit involve the use of apparatus such as galvanometer, learners are sensitised on the genuine one.</li> <li>Inclusive education: All the activities in this unit are designed in a way that they encourage inclusivity in education regardless of gender, cognitive or physical disability.</li> <li>Gender: Where necessary, the content provided in the unit balances on gender by making sure both male and female are represented using neutral words.</li> </ul>	<ul style="list-style-type: none"> <li>Environment and sustainability: The transformer used in the unit uses oil which contributes to pollution of the surrounding once the transformer can no longer function normally and need to be changed. The learners should be sensitised about this in case they become engineers or electrician they will be aware of this fact and dispose the oil in a proper manner.</li> </ul>	<ul style="list-style-type: none"> <li>Environment and sustainability: Since the unit will involve talking about good and bad energy sources in that being good or bad is determined by how they affect the environment, its better to sensitise them about how to protect the environment.</li> <li>Inclusive education: All the activities in this unit are designed in a way that they encourage inclusivity in education</li> </ul>	<ul style="list-style-type: none"> <li>Environment and sustainability: Since the unit will involve use of electrical components such as bulbs, cables fuses among others, it requires the students to be responsible in the disposal of e-waste to avoid polluting the environment.</li> <li>Standardisation Culture: Since the unit discuss in detail on electrical component such as lamps and electrical cables, it call for learners to go for the genuine ones when doing installation. There are so many cheap but counterfeit electrical components.</li> <li>Inclusive education: All the activities in this unit are designed in a way that they encourage inclusivity in education regardless of gender, cognitive or physical disability.</li> <li>Comprehensive sexuality: The unit has taken care of reproductive health in comprehensive sexuality, question 6 of exercise 10.2 sensitises</li> </ul>
--	---	---	--	---	---

			<ul style="list-style-type: none"> <li>Inclusive education: Most of the activities in this unit are designed in a way that they encourage inclusivity in education regardless of gender, cognitive or physical disability.</li> <li>Comprehensive sexuality: The unit addresses birth defected caused by depression due to living near a high voltage power lines. The learners are sensitised to avoid living near them.</li> <li>Gender: The content in this unit balances on gender by using information that applies to both male and female.</li> </ul>	<p>regardless of gender, cognitive or physical disability.</p> <ul style="list-style-type: none"> <li>Gender: the content in the unit takes care of the gender balance.</li> </ul>	<p>learners on HIV and AIDS and the need to know their HIV status.</p> <ul style="list-style-type: none"> <li>Gender: Where necessary, the content provided in the unit balances on gender by making sure both male and female are represented using neutral words.</li> <li>Financial education: Since the unit has discussed lamps as one of the electrical components required for house electrical installation, the learners have been sensitised to use energy saver lamps to reduce electrical cost.</li> </ul>
<p><b>Assessment Strategies of Key Unit competence</b></p>	<ul style="list-style-type: none"> <li>Pre-emptive problem statement at the beginning of the Unit</li> <li>Practical Activities 6.1 – 6.11;</li> <li>Assessment exercise at the end of each lesson</li> <li>Revision questions at the end of the Unit</li> </ul>	<ul style="list-style-type: none"> <li>Pre-emptive problem statement at the beginning of the Unit</li> <li>Practical Activities 7.1 – 7.12</li> <li>Assessment exercise at the end of each lesson</li> <li>Unit test 7 at the end of the unit.</li> </ul>	<ul style="list-style-type: none"> <li>Pre-emptive problem statement at the beginning of the Unit</li> <li>Practical Activities 8.1 – 8.8</li> <li>Assessment exercise at the end of each lesson</li> <li>Unit test 8 questions at the end of the Unit.</li> </ul>	<ul style="list-style-type: none"> <li>Pre-emptive problem statement at the beginning of the Unit</li> <li>Practical Activities 9.1 – 9. 8</li> <li>Assessment exercise at the end of each lesson</li> <li>Revision questions at the end of the Unit</li> </ul>	<ul style="list-style-type: none"> <li>Pre-emptive problem statement at the beginning of the Unit</li> <li>Practical Activities 10.1 – 10.9</li> <li>Assessment exercise at the end of each lesson.</li> <li>Unit test 10 questions at the end of the Unit</li> </ul>

	<b>UNIT 11: Basic alternating current circuits.</b>	<b>UNIT 12: Refraction of light</b>	<b>UNIT 13: Telecommunication Channels</b>	<b>UNIT 14 Properties of physical processes affecting plant growth</b>	<b>UNIT 15 Environmental phenomena and related physics concepts</b>
<b>Number of periods</b>	12	9	9	9	9
<b>Key Unit Competence</b>	By the end of the unit the learner should be able to analyse and carry out a simple electric installation.	By the end of the unit the learner should be able to explain refraction of light phenomenon.	By the end of this unit the learner should be able to differentiate telecommunication channels.	By the end of this unit, the learner should be able to describe the physical properties affecting plant growth.	By the end of this unit, the learner should be able to relate physics concept with environmental phenomena.
<b>Number of Lessons</b>	12	8	4	9	9
<b>Equipment/ Learning/ Teaching Materials Required</b>	<ul style="list-style-type: none"> <li>• Capacitors</li> <li>• Coil</li> <li>• Switch</li> <li>• Dry cells</li> <li>• Ammeter</li> <li>• Low 50Hz frequency generator</li> <li>• Bulb</li> <li>• Internet</li> <li>• Reference book</li> <li>• A.C source</li> <li>• Resistors</li> <li>• connecting wires</li> <li>• Galvanometer</li> <li>• Bicycle dynamo</li> <li>• Voltmeter</li> </ul>	<ul style="list-style-type: none"> <li>• Transparent media</li> <li>• Paper protractor</li> <li>• Soft board</li> <li>• Plane mirror</li> <li>• Stand</li> <li>• Semi circular</li> <li>• Ray box</li> <li>• Prisms</li> <li>• Mathematical set</li> <li>• Lenses</li> <li>• Metre rule</li> <li>• Screen</li> <li>• Internet</li> <li>• Colour filters</li> <li>• Reference books</li> </ul>	<ul style="list-style-type: none"> <li>• Simple string telephone cables</li> <li>• Data transmission cables</li> <li>• Twisted power cables</li> <li>• Tv cables</li> <li>• Optical cables</li> <li>• Chart with drawings of wireless transmission</li> <li>• Internet</li> <li>• Reference books</li> </ul>	<ul style="list-style-type: none"> <li>• Student's Book</li> <li>• Internet</li> <li>• Different types of soil</li> </ul>	<ul style="list-style-type: none"> <li>• Student book</li> <li>• Internet</li> <li>• Metallic rod</li> <li>• Bunsen burner</li> <li>• Water</li> <li>• Beakers</li> <li>• Ink</li> <li>• Candle wax</li> <li>• Small nails</li> <li>• Retort stand</li> <li>• Tripod stand</li> <li>• Steel wire</li> <li>• Radio</li> <li>• Match box</li> <li>• Litter</li> </ul>

	<p>Students to use group work to carryout Activities .11 –11.9</p> <ul style="list-style-type: none"> <li>• Creativity and innovation: In this era of digital devices, the student is encouraged to be creative and innovative in the use of a.c circuit components as such how can you develop a mobile. The concepts learnt in this unit give the student a better position of doing that.</li> <li>• Communication skills: Most of the activities in this unit require group discussions and presentations. Every time the</li> </ul>	<p>Students to use group work to carryout Activities 12.1 – 12.27</p> <ul style="list-style-type: none"> <li>• Creativity and innovation: The activities in this unit call in the creativity and innovation of the learners. The teacher should probe, use leading question so on to open up the learner in this respect. Natural phenomenon e.g. rainbow have been included. Introduce in this unit to help the learners communicate with nature.</li> <li>• Communication skills: Most of the activities in this unit require group discussions and presentations. Every time the student participates in a discussion or presents</li> </ul>	<p>Students to use groupwork to carryout Activities 13.1 – 13.9</p> <ul style="list-style-type: none"> <li>• Creativity and innovation: Most activities in this unit require creativity and innovativeness of the coming up with ways of communication and best channel to use</li> <li>• Communication skills: Most of the activities in this unit require the student discussions and presentations. Every time the student participates in a discussion or presents findings to the class, his/her communication skills are enhanced.</li> </ul>	<p>Students to use group work to carryout Activities 14.1 – 14.11</p>	<ul style="list-style-type: none"> <li>• Plain paper (and manila paper)</li> <li>• Greenhouse structure</li> <li>• Basin</li> <li>• Atlas</li> </ul> <p>Students to use group work to carryout Activities 15.1 – 15.17</p>
<b>Activities/ Techniques Practiced</b>					



discussion or presents findings to the class, his/her communication skills are enhanced.	findings to the class, his/her communication skills are enhanced.	<ul style="list-style-type: none"> <li>• Entrepreneurship and business development: The unit deals with communication system in order this provides an organogram that represents management structure in a typical business organization</li> <li>• Citizenship and national identity: To foster citizenship and national identity, most of the content, assessments and activities in this unit are contextualized to fit into Rwanda tenets that promote a sense of cultural heritage, national identity and patriotism.</li> </ul>	<ul style="list-style-type: none"> <li>• Entrepreneurship and business development: The unit deals with communication system in order this provides an organogram that represents management structure in a typical business organization</li> <li>• Citizenship and national identity: To foster citizenship and national identity, most of the content, assessments and activities in this unit are contextualized to fit into Rwanda tenets that promote a sense of cultural heritage, national identity and patriotism.</li> <li>• Problem solving: The problem statement, activities and most exercises require the students to brainstorm which is crucial in developing their mental ability to select the right tools and procedure for solving a problem.</li> </ul>	
<ul style="list-style-type: none"> <li>• Citizenship and national identity: To foster citizenship and national identity, most of the content, assessments and activities in this unit are contextualized to fit into Rwanda tenets that promote a sense of cultural heritage, national identity and patriotism.</li> </ul>	<ul style="list-style-type: none"> <li>• Entrepreneurship and business development: Figure 12.5 shows how image is formed. Image formation can trigger the interest of learners to involve them in a photographic business. Citizenship and national identity: To foster citizenship and national identity, most of the content, assessments and activities in this unit are contextualized to fit into Rwanda national identity that promotes a sense of cultural heritage and patriotism.</li> <li>• Problem solving: In refraction of light, the transmission of information for long distance has been overcome by one of concept of optical fibre.</li> </ul>	<ul style="list-style-type: none"> <li>• Entrepreneurship and business development: Figure 12.5 shows how image is formed. Image formation can trigger the interest of learners to involve them in a photographic business. Citizenship and national identity: To foster citizenship and national identity, most of the content, assessments and activities in this unit are contextualized to fit into Rwanda national identity that promotes a sense of cultural heritage and patriotism.</li> <li>• Problem solving: In refraction of light, the transmission of information for long distance has been overcome by one of concept of optical fibre.</li> </ul>		
<ul style="list-style-type: none"> <li>• Citizenship and national identity: To foster citizenship and national identity, most of the content, assessments and activities in this unit are contextualized to fit into Rwanda tenets that promote a sense of cultural heritage, national identity and patriotism.</li> </ul>	<ul style="list-style-type: none"> <li>• Problem solving: In a.c circuit, student are encouraged to design circuits to solve problem circuits that are mostly used in domestic and industrial application.</li> </ul>	<ul style="list-style-type: none"> <li>• Problem solving: In a.c circuit, student are encouraged to design circuits to solve problem circuits that are mostly used in domestic and industrial application.</li> </ul>		

		<p>Problems in exercises are such that student are encouraged in problem solving.</p>		<ul style="list-style-type: none"> <li>• Creativity and innovation: All the activities in this unit requires the creativity and innovativeness of the learner in answering discussion questions</li> <li>• Communication skills: The activities in this unit require group discussions and presentations.</li> <li>• Problem solving: The problem statement, activities and assessment questions in this unit require students to brainstorm hence developing their mental ability to select the right tools and procedure for solving a problem.</li> </ul>	<ul style="list-style-type: none"> <li>• Entrepreneurship and business development: teaching the learners on the best forms of energy sources and giving them alternative options teaches them how to save.</li> <li>• Creativity and innovation: Most activities in this unit require creativity and innovativeness of the learner in discussion questions and questions which require their take.</li> <li>• Communication skills: Most of the activities in this unit require the student discussions and presentations.</li> <li>• Citizenship and national identity: To foster citizenship and national identity, most of the content, assessments and activities in this</li> </ul>
					<p>unit are contextualized to fit into Rwanda tenets that promote a sense of cultural heritage, national identity and patriotism.</p> <ul style="list-style-type: none"> <li>• Problem solving: The problem statement, activities and most exercises require the students to brainstorm which is crucial in developing their mental ability.</li> </ul>

<p><b>Cross-cutting issues Addressed</b></p>	<ul style="list-style-type: none"> <li>Environment and sustainability: Since the unit will involve use of electronic materials the learners have been encouraged to be responsible in the disposal of e-waste to avoid polluting the environment.</li> <li>Standardisation Culture: The unit involve use of items such as galvanometer, voltmeter, ammeter</li> </ul>	<ul style="list-style-type: none"> <li>Environment and sustainability: The unit involve uses of lenses and other materials. The learners are required to dispose them well in case they break to avoid polluting the environment</li> <li>Standardisation Culture: Use of genuine lenses, and other items is called for in this unit.</li> </ul>	<ul style="list-style-type: none"> <li>Environment and sustainability: Since the unit will involve use of hardware products such as computer, TV sets cables among others, the unit requires the students to be responsible in the disposal of e-waste to avoid polluting the environment.</li> <li>Standardisation Culture: Since the unit deals with the items such as computer, TV set cables among others, required to go for a genuine items. Cheap is expensive.</li> </ul>	<ul style="list-style-type: none"> <li>Environment and sustainability: most of the activities like activity 15.10, in this unit, the learners will be taught the problems the environment is facing. Sensitize the learners on how to protect the environment.</li> <li>Gender: the content in the unit takes care of the gender balance.</li> </ul>
--	---	--	---	--

	<p>capacitors bulbs among others, the learners are advised to go for genuine ones when they are purchasing them.</p> <ul style="list-style-type: none"> <li>• Inclusive education: Most of the activities in this unit are designed in a way that they encourage inclusivity in education regardless of gender, cognitive or physical disability.</li> <li>• Gender: Where necessary, the content provided in the unit balances on gender by making sure both male and female are represented using neutral words. words like boys, girls are avoided</li> </ul>	<ul style="list-style-type: none"> <li>• Inclusive education: Most of the activities in this unit are designed in a way that they encourage inclusivity in education regardless of gender, cognitive or physical disability.</li> <li>• Gender: The content in this unit balances on gender by using information that applies to both male and female. Words like man, woman, boy and girl are avoided</li> </ul>	<ul style="list-style-type: none"> <li>• Inclusive education: All the activities in this unit are designed in a way that they encourage inclusivity in education regardless of gender, cognitive or physical disability.</li> <li>• Gender: Where necessary, the content provided in the unit balances on gender by making sure both male and female are represented using neutral words.</li> </ul>		
--	--	---	--	--	--

<p><b>Assessment Strategies of Key Unit competence</b></p>	<ul style="list-style-type: none"> <li>• Pre-emptive problem statement at the beginning of the Unit</li> <li>• Practical Activities 11.1 – 11.9</li> <li>• Assessment exercise at the end of each lesson</li> <li>• Unit test 11 at the end of the unit.</li> </ul>	<ul style="list-style-type: none"> <li>• Pre-emptive problem statement at the beginning of the Unit</li> <li>• Practical Activities 12.1 – 12.27</li> <li>• Assessment exercise at the end of each lesson</li> <li>• Unit test 12 at the end of the unit.</li> </ul>	<ul style="list-style-type: none"> <li>• Pre-emptive problem statement at the beginning of the Unit</li> <li>• Practical Activities 13.1 – 13.9</li> <li>• Assessment exercise at the end of each lesson</li> <li>• Unit questions on the unit test 13 at the end of the Unit</li> </ul>	<ul style="list-style-type: none"> <li>• Pre-emptive problem statement at the beginning of the Unit</li> <li>• Practical Activities 14.1 – 14.11</li> <li>• Assessment exercise at the end of each lesson</li> <li>• Revision questions at the end of the Unit</li> </ul>	<ul style="list-style-type: none"> <li>• Pre-emptive problem statement at the beginning of the Unit</li> <li>• Practical Activities 15.1 – 15.17</li> <li>• Assessment exercise at the end of each lesson</li> <li>• Revision questions at the end of the Unit</li> </ul>
--	---	--	--	---	---

## 1.4: Planning to teach

The two most important documents in planning to teach are the schemes of work and the lesson plan.

### 1.4.1 Schemes of work

A scheme of work is a collection of related units and subunits drawn from the syllabus and organized into lessons week by week for every term. It is also a forecast or plan that shows details under these sub-headings:

#### *Date*

Refers to the date of the day when the lesson will be taught.

#### *Week*

Refers to the week in the term e.g. 1, 2, 3, etc.

#### *Unit title*

This specifies the title of the unit from which the lesson is derived.

#### *Lesson title and evaluation*

Refers to the lesson being taught in that week e.g. lesson 1, 2, 3 and 4, etc, and the type of evaluation to be carried out.

#### *Learning Objectives*

Specifies what learners are expected to achieve at the end of the lesson.

#### *Teaching methods, and techniques and evaluation procedures*

Indicates the methods and techniques to used in the teaching/learning process and how evaluate.

#### *Learning resources and references*

Resources refers to any materials that will be used by the learner and the teacher for learning and teaching.

#### *References*

These are books or other materials that will be consulted or used in the teaching process. Books that learners will use should also be shown here; indicating the actual pages.

#### *Observations*

This should be a brief report on the progress of the lesson planned in the scheme of work. Such reports could include 'taught as planned'. 'Not taught due to abrupt visit by County Director of Education.' 'Children did not follow the lesson, it will be repeated on... (Specific date).

### 1.4.2 Lesson plan

A lesson plan is a detailed outline of how the teacher intends to carry out a specific lesson.

The following Important sub-headings of a Lesson Plan

#### *Administrative details*

Date..... Subject.....

Class.....Teacher

Time..... Roll.....

#### *Unit title*

The name of the unit as in the syllabus.

#### *Key unit competence*

This is/are the competence(s) that the learner is expected to achieve at the end of the unit.

#### *Lesson title*

The content area to be taught in the lesson.

#### *Instructional Objectives*

These represent what the teacher

anticipates learners to achieve by the end of the lesson. Objectives should be clear and specific. They should also be stated in behavioural terms, that is, in a way that the outcome can be seen, displayed or measured. In mathematics, one should distinguish between knowledge, skill and attitude objectives.

### ***Learning/teaching resources***

Any materials and apparatus that the learners and the teacher will use during the lesson.

### ***References***

Any resources consulted or used by the teacher to prepare the lesson as well as any books that the learners will use during the lesson.

### ***Introduction***

This is the start of the lesson. The teacher should motivate the learners by creating learning situations that interest learners e.g. posing a problem, telling an amusing but relevant story or episode, showing an object or picture that arouse their interest. The introduction should link what the learners have already learnt with what they are going to learn.

### ***Presentation/lesson development***

This should mainly include the activities that learners and the teacher will perform in order to achieve the stated objectives; as well as the questions that learners will answer as they do the various activities.

It is convenient to distinguish between the learners' and teacher's activities under two columns.

### ***Summary/conclusion: (Consolidation)***

This is the step in which the lesson activities are tied up or consolidated to emphasise the main points, summarize the lessons or make conclusions. The summary

should correspond to the objectives stated for that lesson.

### ***Comments/self-evaluation:***

Teacher should write remarks on whether the objectives were achieved or not and what he or she intends to do to improve on the weak points noted during the lesson.

This teacher's book has been written to help you guide learners to learn physics in the most enjoyable and captivating manner. You are reminded to always arouse the curiosity of learners as you teach. Some things that you may do before you go for a lesson include:

- Going through the expected learning outcomes – this should help guide the manner of teaching.
- Reading through the unit for the lesson in advance to get an overview of the content required.
- Forming a mental picture of the teaching situation and the ways in which you will interact with learners when dealing with the suggested activities.
- Collecting the materials that will be needed during the lesson in advance.
- In some cases, try out the suggested activities / experiments in advance to avoid embarrassments like - the experiment failing to work during the lesson.
- Remember: The suggested teaching activities in this book are just a guide. You may not need to follow them to the letter! Feel free to incorporate other innovative teaching methods that will help in delivering the intended content optimally.

# SAMPLE LESSON PLAN

Term	Date:	Subject:	Class:	Unit	Lesson	Duration	Class Size:
1	8/8/17	Physics	S3	2	$\frac{4}{8}$	40 minutes	40
Type of Special Educational Needs to be catered for in the lesson and number of learners in each category				<b>Speech impaired:</b> 1 pupil stammers a lot while talking. He will be given other roles in the activity apart from reporting the findings from the activities			
<b>Unit title</b>	<b>Friction force and Newton's laws of motion</b>						
<b>Key Unit Competence</b>	By the end of this unit, the learner should be able to perform experiments involving Newton's laws of motion and friction.						
<b>Title of the Lesson</b>	Newton's second law of motion.						
<b>Instructional Objectives</b>	Using a heavier and a lighter trolleys and a rubber band, the learner will be able to derive the mathematical expression of Newton's second law of motion and solve accurately problem related to it.						
<b>Plan for this Class (location): in / outside:</b>	This class will be held in the laboratory .						
<b>Learning materials</b>	<ul style="list-style-type: none"> <li>• Two trolleys (Massive and light)</li> <li>• A spring balance or a rubber bands</li> <li>• Tennis ball</li> <li>• Small rectangular pieces of wood</li> <li>• Light paper ball.</li> <li>• Textbooks</li> </ul>						
<b>Timing for each step</b>	<b>Description of Teaching and Learning Activity</b>					<b>Generic competencies and cross cutting issues to be addressed</b>	
	The learners perform the experiment with the guidance of the teacher and solve problems related to Newtons Second law of motion using the derived expression and the skills acquired from the experiment.						
	<b>Teacher Activity</b>		<b>Learner Activity</b>				
<b>Introduction 5 min</b>	<ul style="list-style-type: none"> <li>• Prompting learners to explain the cause of the following real life scenario using their prior knowledge of Newton's laws of motion:  <i>"It requires a greater force to stop, a heavier vehicle than a light one if they are travelling at the same speed/car"</i></li> <li>• The teacher introduces the lesson by building on the learners responses about the scenario.</li> </ul>		<ul style="list-style-type: none"> <li>• Brainstorm on the scenario and suggest possible explanation using Newton's laws of motion.</li> </ul>		<ul style="list-style-type: none"> <li>• <b>Communication skills</b> will be enhanced through discussions</li> <li>• <b>Critical thinking</b> is enhanced in interpreting the scenario</li> </ul>		



<p><b>Development of Lesson</b></p> <p><b>30mins</b></p>	<ul style="list-style-type: none"> <li>Organise the learner to do Activity 2.4 outlined in the student's book page 32 on demonstration of Newtons second law of motion.</li> <li>Facilitating all learners including those with challenges in performing the activity.</li> <li>Schedules and supervises groups presentations and give feedback on the activity after presentation and prompting learners to derive the mathematical expression representing Newton's Second law.</li> <li>Instructs learners to discuss Examples 2.4 and 2.5 on solving problems involving Newtons second law of motion given learners book page 33.</li> <li>Instructs learners to do some questions in Exercise 2.2 in the learner's book page 34 and marks the learner's work.</li> </ul>	<ul style="list-style-type: none"> <li>Performing activity 2.4, on demonstration of newtons second law of motion, following the steps outlined in the students book page 31 - 32.</li> <li>Preparing a report on their observation in readiness for presentation</li> <li>Presenting the findings from the activity and correcting their work based on the feedback from the teacher and other groups.</li> <li>Building on the feedback that <math>F \propto m</math> and <math>F \propto a</math> to derive the mathematical expression representing Newton's Second law (<math>F = ma</math>).</li> <li>Discussing the examples given by the teacher using the knowledge gained from the activities, and seeking clarification from the teacher, in readiness to do Exercise 2.2</li> <li>Solving problems given in Exercise 2.2 in the learner book page 35.</li> </ul>	<p><b>Critical thinking</b> is enhanced while performing the activities</p> <p><b>Peace and values</b> are dressed through cooperation in performing activities</p> <p><b>Gender</b> is addressed in assigning roles in respective groups.</p> <p><b>Problem solving</b> - will be enhanced as learner solve problems given in exercise 2.2 .</p> <ul style="list-style-type: none"> <li><b>Communication skills</b> will be enhanced through discussions.</li> </ul>
<p><b>Conclusion 5 mins</b></p>	<p>Summarises the lesson by highlighting the key facts learnt.</p> <p>Give the remaining questions Exercise 2.2 as homework to the learners.</p>	<ul style="list-style-type: none"> <li>Writing down the summary and home work in their notebooks</li> </ul> <p><b>Summary</b></p> <p>Newton's second law of motion states that the rate of change of momentum is directly proportional to the resultant. Force takes place in the direction in which the force acts. It is represented mathematically as <math>F = ma</math></p> <p><b>Home work</b></p> <p>Let the learners do questions 2 - 6 exercise 2.2 in the student's book page 35 - 36</p>	<ul style="list-style-type: none"> <li><b>Listening and Writing skills</b> will be enhanced as by listening and writing the summary in the note books.</li> </ul>
<p>Self evaluation</p>	<p>The lesson was taught successfully because all set learning objectives were achieved.</p>		

## 1.5: Assessment and evaluation methods

### 1.5.1 Definition of assessment

Assessment is the process of evaluating the teaching and learning processes through collecting and interpreting evidence of individual learner's progress in learning and to make a judgment about a learner's achievements measured against defined standards. Assessment is an integral part of the teaching and learning processes. In the new competence-based curriculum assessment must also be competence-based; whereby a learner is given a complex situation related to his/her everyday life and asked to try to overcome the situation by applying what he/she learned.

### 1.5.2 Types of assessment

The two types of assessment that will be employed in the new curriculum is **formative** and **summative** assessment.

#### (a) Formative and continuous assessment (assessment for learning)

Formative or continuous assessment involves formal and informal methods used by schools to check whether learning is taking place.

The teacher will use one or a combination of the following:

- Observation to judge the extend of skills acquisition
- Written tests
- Oral questions
- Project work
- Attitude change – this can be done by asking probing questions and checking

body language as learners respond to the questions.

To achieve this, the student's learners book provides an assessment exercise immediately following the teaching/ learning of each concept to immediately test the learners understanding. It also provides a unit test at the end of each unit to test the learners mastery of the concepts learnt in the entire unit. The Teacher's guide in addition provides remedial and extended activities and exercises for slow and fast learners respectively.

#### (i) Written tests

Under this, learners are given questions or tasks and are required to respond in writing. Examples of written tests are: short answer type questions, structured type questions, filling blanks, multiple choice questions, true-false questions and matching items.

#### (ii) Practical work or Activity

In this category, learners are required to perform a task or solve a problem practically. The teacher then assesses the finished work by looking at the materials used, procedures followed, whether it works or not or whether it is finished. He or she then awards marks accordingly.

#### (iii) Observation

This involves the teacher observing learners as they perform a practical task to assess acquisition of skills and attitude change. The teacher checks ability of the learner to measure, classify, communicate findings, etc. He or she also assesses the learner's curiosity, patience, team and co-operation spirit among others.

#### ***(iv) Oral questions or interviews***

Asking learners questions which require a verbal response such as naming parts of human body, a system or short explanations of a process such as digestion can also be used to assess a learner's level of competence.

#### ***(v) Drawing***

This involves asking learners to draw something they have observed or learnt about. They can also collect data and draw graphs and interpret the graph and give conclusions. This helps to assess their skill in communication through recording.

#### ***(vi) Project work***

In a project, learners undertake a comprehensive study of something in real life over a period of time such as several weeks or even months after which they present a report. In project work, let learners begin from planning stage (come up with a schedule of events), execute the plan, analyse the results and look back (reflect on the challenges encountered during the project and come up with solutions to those challenges (problem-solving skills)).

A teacher can use one or several of these assessment methods depending on the subtopic being studied or the purpose for which assessment is required.

#### **When should the teacher assess learning progress?**

The teacher should decide whether to assess learners at the end of the lesson or at any other appropriate time when enough content has been covered.

#### **(b) Summative assessment (assessment of learning)**

When assessment is used to record a judgment of a competence or performance of the learner, it serves a summative purpose. Summative assessment gives a picture of a learner's competence or progress at any specific moment. The main purpose of summative assessment is to evaluate whether learning objectives have been achieved and to use the results for the ranking or grading of learners, for deciding on progression, for selection into the next level of education and for certification. This assessment should have an integrative aspect whereby a student must be able to show mastery of all competencies.

It can be internal school based assessment or external assessment in the form of national examinations. School based summative assessment should take place once at the end of each term and once at the end of the year. Districts will be supported to continue their initiative to organize a common test per class for all the schools to evaluate the performance and the achievement level of learners in individual schools. External summative assessment will be done at the end of S3.

#### **Item writing in summative assessment**

Before developing a question paper, a plan or specification of what is to be tested or examined must be elaborated to show the units or topics to be tested on, the number of questions in each level of Bloom's taxonomy and the marks allocation for each question. In a competency based curriculum, questions from higher levels of Bloom's taxonomy

should be given more weight than those from knowledge and comprehension level. Before developing a question paper, the item writer must ensure that the test or examination questions are tailored towards competency based assessment by doing the following:

- Identify topic areas to be tested on from the subject syllabus.
- Outline subject matter content to be considered as the basis for the test.
- Identify learning outcomes to be measured by the test.
- Prepare a table of specifications.

- Ensure that the verbs used in the formulation of questions do not require memorization or recall answers only but testing broad competencies as stated in the syllabus.

### 1.5.3 Structure and format of the examination

There will be two papers for Physics subject at ordinary level. Paper 1 consists of closed, semi-structured and open/extended questions while paper 2 is practical. Time will depend on the paper's items and weight. Extra time will be given to learners with special education needs if found necessary.

### Component weighting

Paper 1	Component	Weighting
Paper 1	<p>The paper will measure both knowledge and understanding of the subject matter and acquisition of competences. The question items will be balanced as follows:</p> <ul style="list-style-type: none"> <li>• <b>Assessment of Knowledge and understanding (questions from low levels of Bloom's taxonomy) 30%</b></li> <li>• <b>Assessment of Skills and competences (questions from higher levels of Bloom's taxonomy :application, analysis, evaluation and synthesis) 40%</b></li> </ul>	70%
Paper 2	<p>Practical skills: The paper to measure practical/ experimental skills (Observation, Recording &amp; report writing, Manipulation, Measurement, Planning &amp; designing). The experiments should be drawn from different topic areas of the syllabus.<b>30%</b></p> <p>This paper will consist of experiments drawn from different areas of the syllabus. Candidates will answer all questions</p>	30%

### **1.5.4 Record Keeping**

This is gathering facts and evidence from assessment instruments and using them to judge the student's performance by assigning an indicator against the set criteria or standard. Whatever assessment procedures used shall generate data in the form of scores which will be carefully be recorded and stored in a portfolio because they will contribute for remedial actions, for alternative instructional strategy and feed back to the learner and to the parents to check the learning progress and to advice accordingly or to the final assessment of the students.

This portfolio is a folder (or binder or even a digital collection) containing the student's work as well as the student's evaluation of the strengths and weaknesses of the work. Portfolios reflect not only work produced

(such as papers and assignments), but also it is a record of the activities undertaken over time as part of student learning. Besides, it will serve as a verification tool for each learner that he/she attended the whole learning before he/she undergoes the summative assessment for the subject.

### **1.5.5 Reporting to parents**

The wider range of learning in the new curriculum means that it is necessary to think again about how to share learners' progress with parents. A single mark is not sufficient to convey the different expectations of learning, which are in the learning objectives. The most helpful reporting is to share what students are doing well and where they need to improve.



**Key Unit Competence**

By the end of this unit, the learner should be able to plot and analyse the graphs of linear motion.

**Prerequisites of this unit**

- Knowledge on distance, displacement, speed, velocity, acceleration and free fall of a body and the skills of plotting and interpreting a distance-time, displacement-time, speed-time and velocity-time graphs learnt in S1 unit 2 on the topic of qualitative analysis of linear motion.
- Using small quiz and then question and answer method, ensure that learners recall and understand these concepts level as an introduction to this topic. This is important because the concepts to be learnt in this unit require the learner to apply the knowledge-learnt.
- Knowledge on instantaneous speed velocity and the skills of solving problems related to linear motion learnt in S1 and S2 unit 2. These forms the basis of graph drawing and analysis of the linear motion in this unit.
- Review with the learners the work covered in S1 and S2 on linear motion.
- Make sure that the learners are able to draw graphs before the start of the unit. Emphasis on the importance of choice of scales.

- The learners should have gained skills on graph drawing in mathematics.
- The learners should have prior the knowledge and skills on finding areas of different shapes.

**Crosscutting issues to be addressed**

- *Gender*: The unit comprises of numerous activities that require learners to work in convenient groups. The teacher should organise the class appropriately for various activities. Ensure that the gender issue (if the class is mixed one) is addressed. Use the opportunity to sensitize learners that everybody (whether a boy or girl) deserves equal opportunity in the learning process.
- *Inclusive education*: The unit has a wide range of activities and exercises that encourages inclusiveness of every learner. The teacher should ensure that all learners especially those with special need are involved actively in the learning process.

**Generic competences**

The specific generic competences to be addressed in this unit are:

- *Critical thinking*: This competence will be achieved when the teacher will involve learners in doing activities especially the unit focus activity and answering questions in exercises 1.1, 1.2, 1.3 and unit test 1 that require the learner to explain, discuss and describe the particular concept.



- *Teamwork, cooperation, personal and interpersonal management and life skills*: This competence will be achieved when the teacher will be organising the learners in groups to do different learning activities (that is, unit activities, project activity, doing exercises and unit test).
- *Communication skills*: The competence will be achieved when the teacher ensures that all learners are participating by giving their views in a discussion of different learning activities given in the unit.
- *Research and Problem solving*: This competence will be achieved when the teacher involves learners in activities that require the use of internet and reference books to find solutions to the task given.

### **Vocabulary or key words or concepts**

In the course of learning the concepts in this unit, the learners will discover the meaning of the following new words:

- Constant motion
- Uniform motion
- Non-uniform motion
- Velocity
- Acceleration
- Slopes/gradient
- Scales in graph drawing
- Area under the graph

Ensure that the learners understand the meanings of these words, construct and speak out the physics statement involving them in order for learners to master their meaning and usage.

### **Guidance on problem statement**

In order to motivate learners and make them eager, attentive and active when learning the concepts in this unit, facilitate them to do the unit focus activity outlined in the student's book page 2-3

**Materials required:** a ball, a circular dish

- Organise the learners into convenient groups, depending on the availability the suggested materials. Ensure that each group is properly set up, that is, it has taken consideration of gender issue. If it is a mixed class (should comprise of boys and girls) and different ability (slow and gifted) of learners. Working in groups is important for the learners because it give them an opportunity to share their ideas with other thus learning new concepts from each other. It will also enhance *cooperation, teamwork, personal and interpersonal management, organisational skills* among other competences in learners.
- Provide learners with the materials and ask them to do the unit focus activity provided in the student's book pages 2-3.
- Go around the class to ensure that learners are doing the correct thing. Guide those with challenges especially in ensuring that the ball hits inside the circular dish every time it drops down from a distance. Use this opportunity to let the groups know the importance of participating actively in all the lessons planned for this unit.
- Allow learners to hold a discussion in their groups as they attempt to respond to all questions asked in the activity. This will promote *cooperation,*



*communication skills and leadership skills* among other competences in the learners.

- Guide them in such way that leads to the correct responses to the questions asked in the activity. you can use probing questions such as, how can you use what we learnt on displacement-time, speed-time and velocity-time graphs in Physics S1 and S2 to help you do this step? By doing that, you will be promoting the **critical thinking** of your learners.
- It is possible that a number of groups will have challenges in sketching the required graph. Appreciate them too for the trial. Appreciate the groups that may have gotten the correct sketch and accounted well. Some groups may not have got it right. Appreciating those who got it right and those who missed it is important because it will help learners to learn to respect the opinion of others whether right or wrong thus training them how to become tolerant and value **peace** among themselves.
- Use their feedback from the activity to trigger their curiosity and help them to see the need of learning the concepts in this unit.
- Let them know that the correct answers will be obtained in the process of learning the concepts learned unit so that by the end of it, they can be able to respond correctly to all questions asked in the unit focus activity.

### Attention to special needs

In order to involve all learners in the learning process, you must know all of them especially those with special needs in class.

- Some of the questions in the exercises can be given to gifted learners. Prepare additional more challenging questions for them. (See remedial questions for gifted learners have been provided at the end of this unit in this Teacher's guide unit)
- For slow learners, organise remedial lessons for them. Guide them through the activities and exercise once again and more slowly to help them understand.

### List of lessons

Lesson No.	Lesson title	Number of period
1.	Uniform and non-uniform linear motion	2
2.	Plotting graphs of linear motion	2
		1
3.	Plotting and analysing graphs of linear motion (worked example)	2
4.	Unit assessment	1
	Total	8

### Lesson development

#### Lesson 1: Uniform & non-uniform motion

#### Learning objective

The learner should be able to describe graphs of uniform linear motion.

### Teaching aids

- Geometrical set
- Graph papers

### Introduction to the lesson

- use question and answer to review the work covered in S1 and S2 sketching graphs of motion. Graphs of distance-time, velocity-time and acceleration-time.
- Guide them to remember that the quantities, distance, velocity and acceleration are usually represented on the y-axis and time on the x-axis.
- Ask the students to volunteer to sketch some graphs on the chalk board as others evaluate how accurate they are. A few students to present their work to class. Understand the concept.
- Link the introduction to the lesson of the day i.e. drawing and interpreting uniform and non-uniform motion.

### Learning activities

#### Teaching guidelines for activity 1.1

- Organise learners into small, suitable groups. Ask them to perform activity 1.1 outlined on pages 3-4 in the student's book, that is, to identify uniform and non-uniform linear motion. Working with small group will help you to monitor all students and ensure they are actively involved. It will also enhance *personal* and *interpersonal management* relation in learners.

- Ask the groups to report their findings to the class by filling in a table on the board. (Design a suitable table for them). This will enhance *writing skills*, *teamwork* and *cooperation* among other competences.
- Hold a class discussion on their findings. Point out their mistakes and misconceptions in their findings.

### Synthesis

- Having done the activity and discussed their findings, help them to understand following facts:
  1. Uniform motion is the kind of motion in which a body covers equal distances in equal intervals of time. It does not matter how small the time intervals are, as long as the distances covered are equal. If a body is involved in rectilinear motion and the motion is uniform, then the acceleration of the body must be zero.
  2. A car moving on a straight road without any change in its velocity is example. A Ball rolling on a floor without changing its velocity is also an example of uniform Motion.
  3. Non-Uniform motion on the other hand is the kind of motion in which a body moves with varying velocity along a straight line.
  4. The graphs, for example,  $v - t$ ,  $a - t$  used to present uniform rectilinear motion.

## Assessment

Ask learners to do questions 1 and 4 of exercise 1.1 given in the student's book page 8.

### Answers to activity 1.1 student's book page 3-4

Uniform motion is a type of motion where bodies move with a constant velocity on with zero acceleration along a straight path. While non uniform motion is motion in which a body moves with a varying velocity/speed.

Uniform motion are (b) and (e) because the body covers equal distances in equal intervals of time.

Non-uniform motion are (a), (c), (d), (f), (g) and (h) because the body covers unequal distances in equal time interval.

## Lesson 2: Plotting graphs of linear motion

### Learning objective

The learner should be able to plot graph of distance –time and velocity-time graphs.

### Teaching aids

- Graph papers.
- Geometrical set

### Introduction to the lesson

- Link lesson 1 and 2 by informing the students that, in lesson 1, they have been analysing already drawn graphs. However in lesson 2 they will actually plot the graphs from data presented to them or data they obtain from an experiment themselves.
- Review the important aspects of drawing a good graph e.g. proper scale (depending on the data) labeling axis, stating the units of the quantities presented, which quantity should be

on x or y -co-ordinates. The learners already have learnt these concepts in mathematics and Physics senior 1 and 2. Establish that the learners recall and understand them well as an introduction to this part of the unit. This is important because it will require the learner to apply the knowledge learnt and the skills already acquired.

## Learning Activities

### Teaching guidelines for activity 1.2

- You have already grouped the learners before when they were doing activity 1.1, you may decide to maintain the groups for this activity or form new groups. Forming new group sometimes is important because it help learners to interact and share new ideas from different learners. It also promotes **teamwork, cooperation** among other competences in learners.
- Provide the learners with the graph papers and ensure they have personal mathematical geometrical set prior to the lesson.
- Ask learners to do activity 1.2 provided in the student's book pages 4-5, that is, to plot a distance-time graph of an object moving with a uniform speed.
- Go around the class to check whether the learners are doing the right thing. Visit as many groups as possible. Help those who may have challenges of choosing a good scale for drawing the graph, especially, the slow learners.
- Let them suggest suitable scales .
- Allow them to draw the graph and describe the motion as a group on their own.

- Let them display their graph on the board.
- Call them in front and discuss their graphs. Develop a marking scheme together.
- Hold a brief discussion on their graphs drawn and description given. Give the learners opportunity to point out errors and omission from other groups' findings. Allow them to exchange their graphs and mark their colleagues' graphs using the marking scheme. At this point remind learners that people can disagree over an issue but always let it be a constructively.
- Hold a discussion with learners on the discussion given in the student's books to clarify some of the facts learnt.

#### Assessment

Ask learners to do question 3 of exercise 1.1 given in the student's book page 8.

#### Answers to activity 1.2 student's book page 4

1. See the graph (Fig. 1.14) at the end of unit 1 in the Teacher's guide page 57.
2. The motion of the body is a uniform. Since the body is covering with equal distances at equal time intervals.

#### Teaching guidelines for activity 1.3

#### Synthesis

Learners having done the activity on their own, drawn the graph and discussed their findings, then

- Draw the graph on the chalkboard (on the square part) or you may have drawn it on the graph papers and photocopied to have enough copies for your learners prior to the lesson.
- Take them through the steps of drawing the expected graphs, that is, how to choose a suitable scale, for instance the graph should fill at least  $\frac{3}{4}$  page of the grid provided.
- Guide them on how to obtain the slope of the graph that is change in quantity given at y-axis divided by change in quantity given in x-axis.
- Explain/interpret the motion of the body whose data has been provided.
- Show them how to obtain the units of the slope, that is, from the units of the quantities given in the y and x-axes.
- Organise learners in pairs to do activity 1.3 given in the student's book page 6. The teacher should always remember that it is good for learners to work in groups but those groups formed should reflect gender balance (in case of a class comprises of boys and girls) and different abilities (slow and faster learners).
- Ask learners to do activity 1.3 in the student's book page 6, that is, to plot a distance-time graph of an object with non-uniform speed.
- Since learners have already learnt a lot in regard to drawing of graphs in activity 1.2, let them do this activity alone. Give guidance only when necessary especially to slow learners.
- Hold a comprehensive discussion on their findings and allow learners to give their supportive argument on their findings. This will enhance communication skills in learners.

## Synthesis

Let learners understand the following facts:

1. Non-uniform motion is one in which a body covers unequal distances in equal intervals of time no matter how small the time intervals.
2. The slope from distance-time graph represents the speed of the body.

## Assessment

Ask learners to do questions 2 and 3 exercise 1.1 given in the student's book page 8.

### Answers to activity 1.3 student's book page 6

2. The sample graph (fig. 1.15) is given in this teachers guide page 57.
3. It is a non-uniform motion- This is a kind of motion in which a body covers unequal distances in equal intervals of time no matter how small the time intervals.
4. Gradient/slope =  $2.8 \text{ m/s}$ . It represents speed of the object.

### Teaching guidelines for activity 1.4

- Still maintaining the groups used in activity 1.3 or reorganise any group if you think it is necessary to do so, ask learners to do activity 1.4 in the student's book page 8.
- By now the learners should be able to plot the required graphs using the data given. Guide those who may have some challenges especially the slow learners.
- Allow them to discuss their graphs and describe the motion of the body from the graph they have drawn.
- Hold a brief class discussion on their findings

## Synthesis

- Hold a discussion with learners to emphasize the following facts from the activity:

1. Velocity is a speed of a body in a given specified direction
2. Velocity = displacement/time or change in speed/time.
3. The slope of velocity time graph gives acceleration of the body.
4. Distance can be obtained from the velocity-time graph by finding the area under the graph.
  - Lead the learners in the discussion given in the student's book to clarify some of these facts.
  - Guide the learners through example 1.1 in students book page 9-10.

## Assessment

Ask learners to do questions 1 and 2 of exercise 1.2 given in the student's book page 13.

### Answers to activity 1.4 student's book page 8

The velocity - time graph for a body with constant velocity is a straight line parallel to the time - axis. (see fig 1.5 in student's book page 9)

### Teaching guidelines for activity 1.5

- By now the learners should be able to organise themselves appropriately into different groups without your help whenever they are asked to do so. This does not mean you don't need to check and reorganise them where necessary. Therefore, organise them into convenient groups depending the availability of suggested learning materials and let them be ready to do



activity 1.5. Working in groups will enhance *personal and interpersonal management, teamwork and cooperation* among learners.

- Prompt them to see the need of having a group leader and the secretary.
- Provide them with the suggested materials in the activity, that is, *a long tape, wooden block, a runway tick-tape, trolley, ticker-time, carbon disc and cellotape*.
- Lead by the group lead, now ask the learners to do activity 1.5 in the student's book pages 10-11, that is, to determine the distance moved by an object using a velocity-time graph. This will promote leadership skills in learners.
- Guide them through every step of the activity and allow them to do it by their own. Help them to come up with tape chart.
- Let them attempt to answer all questions asked in the activity.
- With the guidance of group leader, allow learners to hold a discussion on their findings. This will promote *leadership and communication skills* in learners.
- Hold a comprehensive discussion on their findings. Let learners point out errors and omission if any from the findings of other groups. Correct them together on the chalkboard.

### Synthesis

Having done the activity, let learners understand the following facts

- The ticker time used is that of 50 Hz.
- The time between the dots is 0.02 seconds equivalent to  $\frac{1}{50}$  s.

- When the tape charts are arranged as shown in fig. 1.8 in students book page 11, it gives the velocity-time graph whose gradient is the acceleration of the body (trolley).
- The area under velocity-time graph gives displacement of the body.

### Assessment

Ask learners to do questions 3 and 4 of exercise 1.2 given in the student's book page 13.

### Answers to activity 1.5 student's book pages 10-11

- In step 3, the distance between them keeps on increasing. This is because the velocity of the trolley keeps on increasing.
- In step 9, the horizontal axis represents the time.
- In step 12, the graph shows that the motion of the trolley increases hence velocity keeps increasing with time.

### Lesson 3: Plotting and analysing graphs of linear motion (worked examples)

#### Learning objective

The learner should be able to analyse distance-time and velocity-time graphs.

#### Teaching aids

- Graph paper.
- Geometrical set.

#### Introduction to the lesson

Let the student differentiate between distance-time and displacement-time graph, speed-time and velocity-time graph. This will help the students to realize that the analysis of the motion is the same only in one the direction is not specified.

## Learning activities

### Teaching guideline

- Ask learners to close their physics textbooks.
- Copy the questions in examples 1.2-1.2 given in the student's book page 14-17 on the chalkboard.
- Ask the learners individually, to attempt the example.
- Attend to anyone of them who may have difficulties in doing the examples.

### Synthesis

Now, write each question on the chalkboard and hold a discussion with learners on how the question should be done. Sum up the lesson by highlighting the most important concepts that are involved in plotting and analysis graphs of linear motion. With learners, Use the Internet and simulation to illustrate, describe and plot various graphs of linear motion.

### Assessment

Ask learners to do exercise 1.3 given in the student's book page 17, individually. Mark their work and guide them appropriately. This will promote *critical thinking* among other competences in learners.

### Summary of unit

- At random, ask different learners to lead others in brief discussion of different concepts highlighted in the unit summary given the student's book pages 18-19. By asking them probing questions, help them recall the concepts.
- Ask learners to go back to the unit focus activity given on page 2. Let them now give the correct solutions to the questions asked therein. Ensure that they have obtained the following:

### Step 4

The height of consecutive rebounces decreases. This is due to force of gravity that reduces the velocity of the ball.

### Step 5

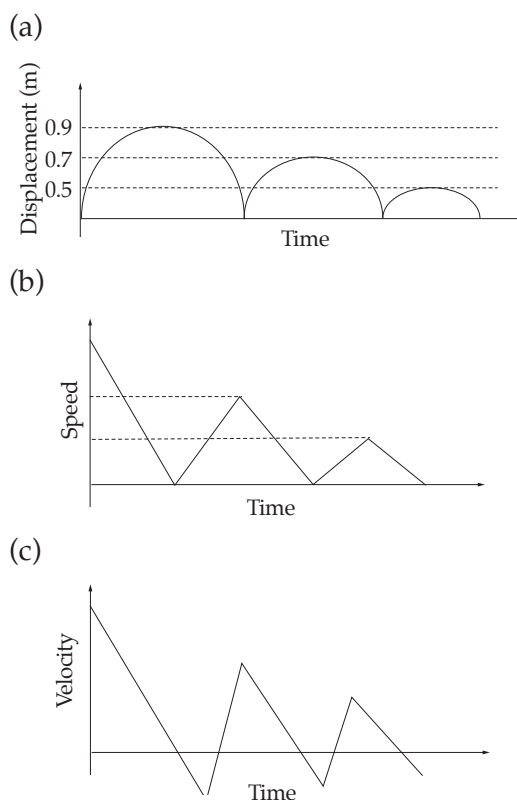

Fig. 1.1: Graphs of learners

### Additional information

- The use of a ticker timer gives a variety of data to be analysed through graphs. Select different cases to generate data e.g. incline plane, dropping objects in air and water etc. Show how the students may use their mobile phone as a stopwatch since you need a more accurate measurement of short duration of time.
- The mathematical transformations between graphs of motion are in fig. 1. 2.

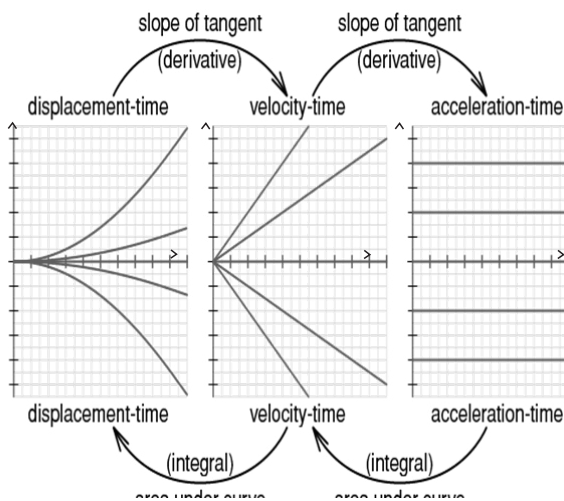
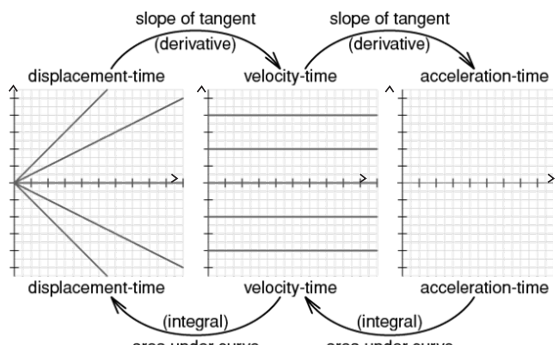

Fig. 1.2: Graphs of motion

#### Lesson 4: unit assessment

Ask learners to do unit test 1 provided in the student's book pages 19-23, individually. Mark their work and hold a discussion on their results. This is important because it will help you as teacher to assess the *communication skills* when discussing the results and whether the learners have attained the objective of the unit. It will also help to promote *critical thinking* in learners.

#### Remedial activities

- Form study groups among students. Each group should have fast and slow learners.

- Give students areas covered in class to present to others.
- Form peer group teaching.
- The use of tickertapes usually gives students hard time in analysis, time, distance or even speed. Run a number of tapes and help those students that may have such difficulties.

#### Remedial questions for the slow learners

- What is a linear motion?
- What does the slope/gradient of the following graphs represents
  - Distance-time graph
  - Speed-time graph
  - Displacement-time graph
  - Velocity-time graph
- (a) Describe the motion in the following graphs of linear motion:

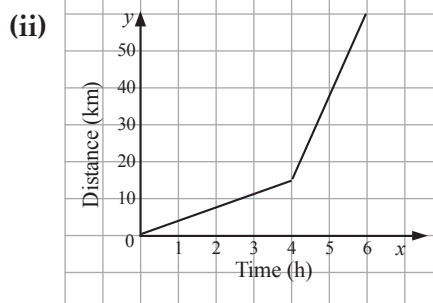
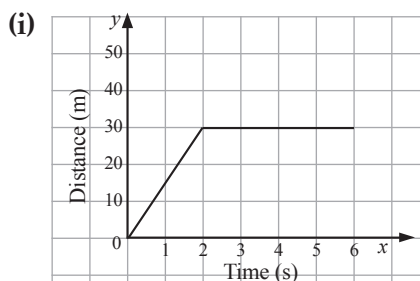



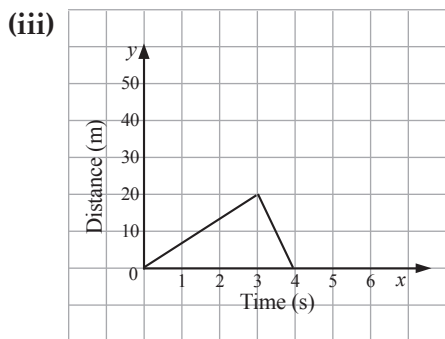

Fig. 1.3

- (b) Calculate the speed in each portion of the graphs in part (a)

**Answers to remedial questions for slower learners**

- Linear motion (also called rectilinear motion) is a motion along a straight line, and can therefore be described mathematically using only one spatial dimension.
- (a) speed (b) acceleration  
(c) Velocity (d) acceleration
- (a) (i) The body moves at a constant speed from 0 to 30 m in 2 s and then it stops.  
(ii) The body moves at a constant speed from 0 to 15 km in 4 hours then from 15 km to 60 km in 2 h at constant speed.  
(iii) The body moves at a constant speed from 0 to 20 m in 3 s then it slow down to rest in 1 s.  
(b) (i) 15 m/s  
(ii) 3.75 m/s, 22.5 m/s  
(iii) 6.67 m/s

**Extended activities**

- Encourage the learners to do projects on areas covered in groups, in class and science fairs.
- Use the Internet to view videos on the graph of linear motion.

**Extended questions for gifted learners**

- (a) A ball is thrown upward, it returns back and hit the ground before bouncing back. Sketch a velocity-time graph of the ball.  
(b) Describe the motion of the ball.
- A man travelled part of the journey to his work place by bus, then got a lift on a motor bike before walking the rest of the journey (fig. 1.4).

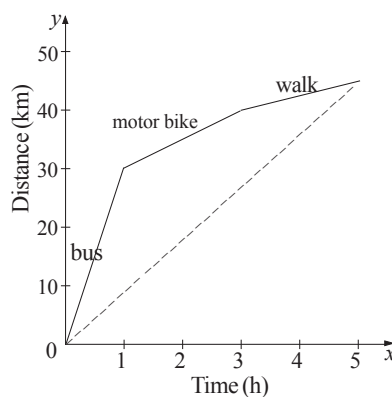
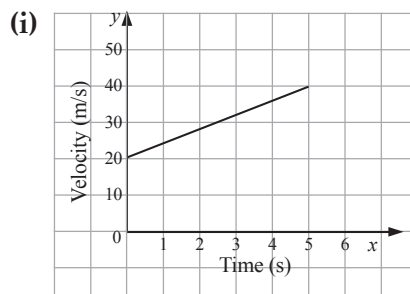

Fig. 1.4

- (a) Find (i) The speed of the bus  
(ii) The speed of the motor bike.  
(iii) His walking speed  
(b) Calculate the gradient of the dotted line and state its units
- (a) Describe the motion in graph shown in fig. 1.5



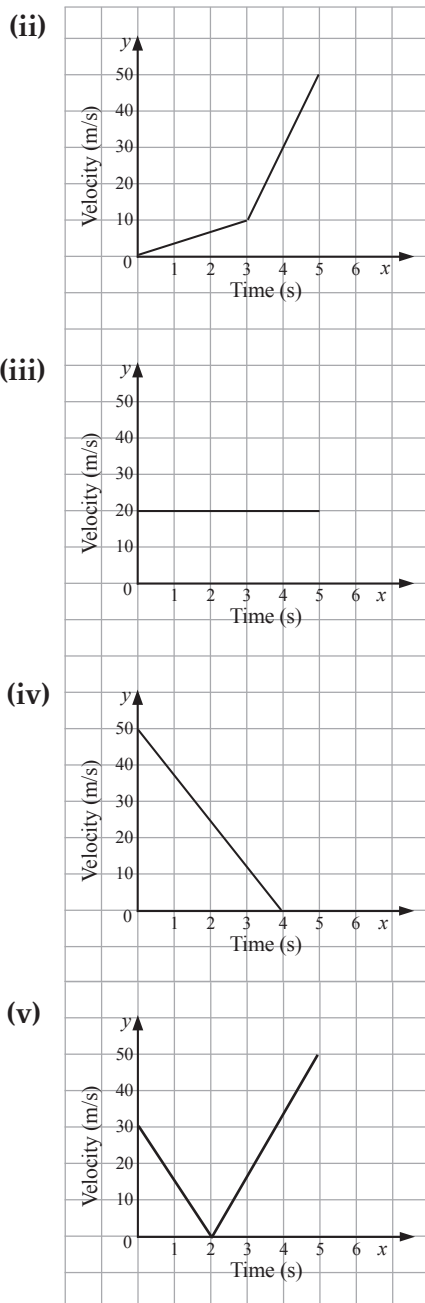

Fig. 1.5

(b) Calculate:

- (i) The acceleration i.e each of graph in part (a).
- (ii) The total distance travelled in each case.

Answer to extended questions for gifted learners

1. (a)

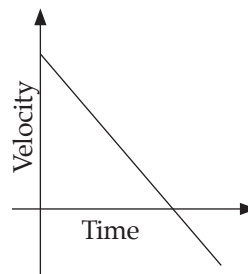

Fig. 1.6

(b) The ball's velocity decreases to zero when it hits the ground and then starts increasing to maximum but in opposite direction as it bounces back.

2. (a) (i) 30 km/h

(ii) 5 km/h

(iii) 2.5 km/h

(b) 9 km/h

3. (a) (i) Increases velocity from 20 m/s to 40 m/s in 5 s.

(ii) Increases velocity from 0 m/s to 10 m/s in 3 s, increase velocity from 10 m/s to 50 m/s in 2 s.

(iii) Moves with constant velocity of 20 m/s for 5 s.

(iv) Changes velocity from 50 m/s to 0 m/s in 4 s.

(v) Reduces velocity from 30 m/s to 0 m/s in 2 s, then increases velocity from 0 m/s to 50 m/s in 3 s.

(b) (i)  $4 \text{ m/s}^2$ ;  $3.33 \text{ m/s}^2$ ;  $20 \text{ m/s}^2$ ;  $0 \text{ m/s}^2$ ;  $12.5 \text{ m/s}^2$ ;  $-15 \text{ m/s}^2$ ;  $16.67 \text{ m/s}^2$

(ii) 150 m; 75 m; 100; 100 m; 105 m

## Answer to exercises and unit test 1

### Exercise 1.1

(Learner's book page 8)

- Uniform linear motion is the motion along a straight line with constant velocity fig. 1.7 shows velocity time graph for the motion.

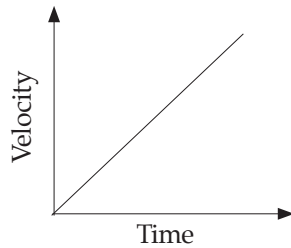

Fig. 1.7

- The gradient represents the speed; It shows the rate at which the distance is increasing with time.
- (a)

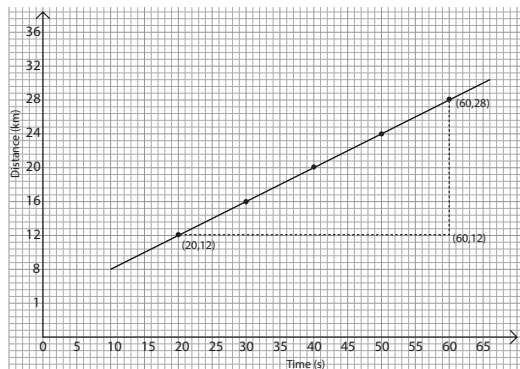

Fig. 1.8

- (b) 0.4 m/s
- (c) The object is moving with constant speed i.e. no acceleration
- (d) Graphs help in visual form communication
- Uniform linear motion is the motion in which velocity is constant i.e. has zero acceleration while non-linear motion has varying velocity i.e. non-zero acceleration

### Exercise 1.2

(Learner's book page 13)

- Speed is a scalar quantity that shows the rate at which an object cover distance while velocity is a vector quantity that shows the rate of change of displacement.
- Acceleration; the rate at which the velocity is changing
- 1500 m/s<sup>2</sup>
- 1600 m/s<sup>2</sup>

### Exercise 1.3

(Learner's book page 17)

- (a) Accelerated motion is where the body moves with changing velocity.
- (b) Non accelerated motion is where a body moves with a constant velocity.
- (c) An example of accelerated motion is a body in uniform circular motion, an object allowed to fall freely to the ground from some height.

An example of non-accelerated motion is a car moving with constant speed in a straight road.

- (a) 
$$\text{Slope} = \frac{\Delta y}{\Delta x} = \frac{\Delta \text{ in displacement}}{\Delta \text{ in time}} = \text{velocity}$$
- (b) 
$$\text{Slope} = \frac{\Delta y}{\Delta x}$$

$$\Delta y = \text{Change in velocity}$$

$$\Delta x = \text{Change in time}$$
- (c) Area under graph  
= Velocity  $\times$  time

$= \text{m/s} \times \text{s} = \text{m} \Rightarrow$  units of displacement

3. (a) 3.2 km  
(b) 48 km

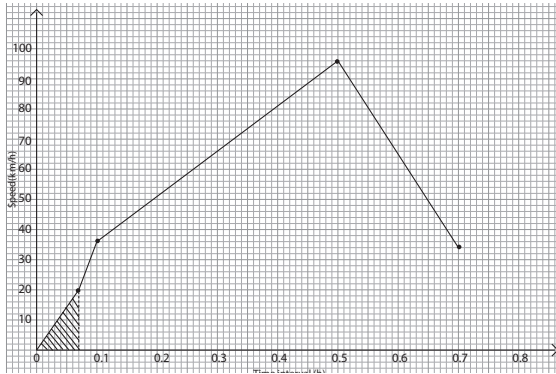

Fig. 1.9

- (d) Indicated on the graph by the shaded part

**Unit test 1**

(Learner's book pages 19-23)

1. C    2. D    3. B    4. C    5. C  
6. D    7. C

8. (a) Athlete A starts from rest and increases his/her velocity to 8 m/s in 30 seconds and reduces his speed uniformly until he/she comes to rest in 20 seconds.

Athlete B starts from the rest and increases his/her velocity to 10 m/s in 30 s and moves with the constant velocity for 20 s.

- (b) 350 m  
9. (a) Uniform velocity is velocity that is not changing

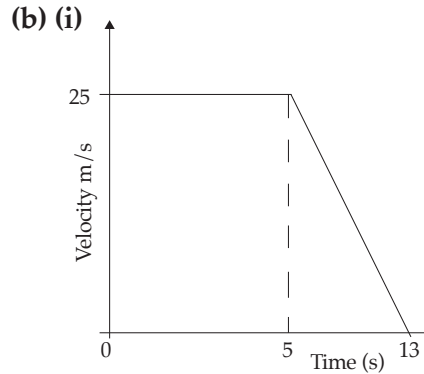
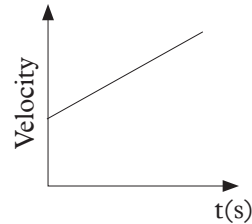

Fig. 1.10

- (ii) 225 m

10. (a) Instantaneous velocity is the velocity of a body at a specific moment in time.  
(b) Average velocity is the sum of initial velocity and the final velocity divided by 2.  
11. (a) Finding the slope of the graph  
(b) Finding the area under the curve  
(c) Finding the slope of the velocity time graph

12. (a)



- (b)

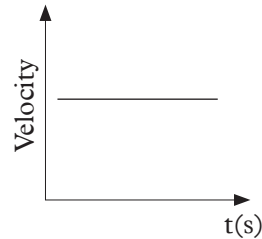

Fig. 1.11

13.

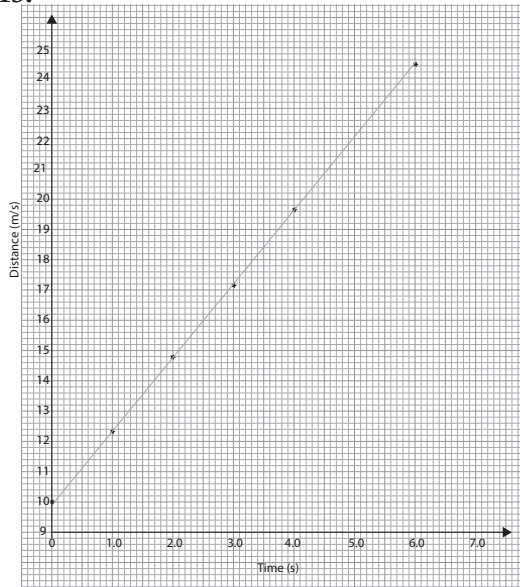

Fig. 1.12

- (b) (i) 16.2 m/s (ii) 11.66 m  
(iii) 2.40 m/s<sup>2</sup>

14.

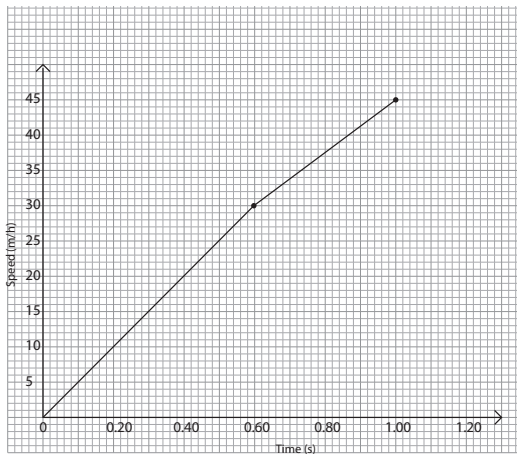

Fig. 1.13

15. 0.75 km

Graph for activity 1.2 (Learner's book page 4 - 5.)

Distance time graph

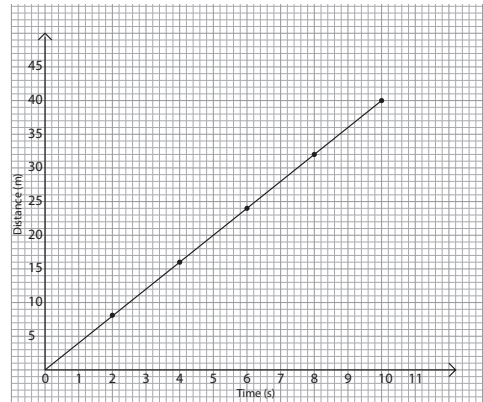

Fig. 1.14

Distance time graph of an object moving with uniform speed

Graph for Activity 1.3 (Learner's book page 6.)

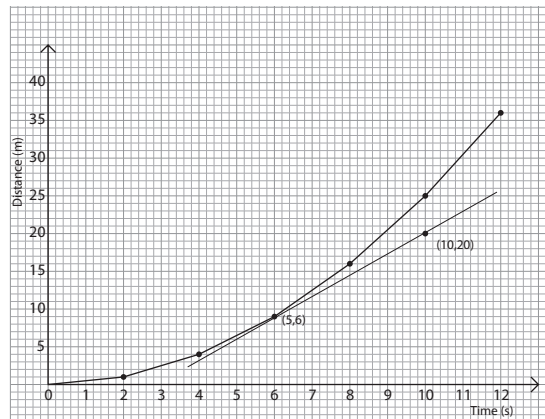

Fig. 1.15

Distance time graph of an object moving with non-uniform speed

$$\text{Slope} = \frac{(20 - 6) \text{ m}}{(10 - 5) \text{ s}} = \frac{14 \text{ m}}{5 \text{ s}} = 2.8 \text{ m/s}$$

**Key Unit Competence**

By the end of this unit, the learner should be able to perform experiments involving Newton's laws of motion and friction force.

**Prerequisite to this unit**

For learners to acquire the knowledge, skills, attitude and values envisaged in this unit with ease, they need to have acquired the following:

- Knowledge on Newton's laws of motions; stating First, Second and Third laws of motion, the skills of solving simple problems involving Newton's laws of motion and appreciating the importance of Newton's laws of motion in our daily lives. These concepts were covered in S1 unit 4 in the Newton's laws of motion (I). The teachers should establish through question and answer method or through a small quiz whether the learners remember the concepts learnt before reviewing again the Newton's three laws of motion in this unit.
- Knowledge on friction force that is stating and explaining the nature of friction force, describing types of friction force, explaining effect of force, skills of identifying factors affecting friction force and appreciating the importance of friction force in our daily lives. These concepts were covered in

S2 unit 3 in the topic of friction force. The teacher should establish through question and answer method whether learners recall and mastered the concepts before introducing them to subtopic of friction in this unit.

- Knowledge on law of conservation of energy learnt in S1 unit 6 in the topic work, power and energy (I) and the skills of explaining the principle of energy. Before introducing the subtopic; conservation of linear momentum, the teacher should ensure that learners recall the basic knowledge learnt on conservation of energy and the skills acquired through question and answer method.
- The skills of measuring static and dynamic friction and determining the coefficient of friction. The learners were facilitated to acquire these skills in S2 unit 3 in the topic of Friction force. The teacher should give a short quiz to ascertain they have these skills before introducing them to determination of coefficient of friction in this unit.

**Crosscutting issue to be addressed**

The specific crosscutting issues to be addressed in the unit are:

- *Gender:* Since the unit will involve demonstration of the Newton's laws of motion involve both boys and girls in the demonstrations of activities. In the unit, pictures of both boys and girls have been used. For example, in

one instance, the picture of a woman is used (1<sup>st</sup> law) while in the other; a picture of man is also used (3<sup>rd</sup> law). The teacher should use those pictures to sensitise learners the importance of treating everybody (both women and men) in the society equally.

- *Inclusive education:* The unit has wide range of activities and exercises that encourages inclusiveness of every learner. Additionally, the picture of Muslim female driver in student's book page 27 should be used by the teacher to sensitise learners that everyone is welcomed to learn regardless of his/her religion.

### Generic competences

The specific generic competences to be addressed in this unit include among others the:

- *Critical thinking:* This competence will be achieved when the teacher will involve learners in doing activities especially the unit focus activity and answering questions in the exercises 2.1, 2.2, 2.3 and unit test 2 that require the learner to explain, discuss and describe particular concepts.
- *Problem solving:* This competence will be achieved when the teacher involve learners in activities and exercises on Newton's laws of motion and in determining the coefficient of friction force.
- *Life skills:* This competence will be achieved when the teacher will draw the attention of the student to the need of wearing safety belt in a moving vehicle.
- *ICT:* This competence will be achieved when the teacher will involve learners

in conducting research from Internet on Newton's laws of motion.

### Vocabulary /Keywords

In the course of learning the concepts in this unit, the learners will discover the meaning of the following new words:

- Momentum
- Impulse
- Elastic collision
- Inelastic collision

Guide the learners to understand the meanings of these words and construct and speak out the physics statement involving them in order to master their meaning and usage.

### Guidance on the problem statement

- In order to focus the learner's attention into the general direction of the unit, the teacher should organise learner into appropriate groups and then provide them with the required materials ( a ball ) for them to do the unit focus activity in the student's book pages 25-26.
- Ask the learners to place the two balls at distance from each other. Let them kick one ball toward the other and observe their velocities before and after collision. Ask them to repeat with the small ball and explain any difference in the velocities. The learners with physical disability can be given balls to place them at a distance while the others are asked to kick it.
- Allow learners to hold a discussion in their groups as they attempt to respond to all questions asked in the activity. This will promote cooperation, communication skills and leadership skills among other competences in the learners.



- Use their feedback to guide them in such away that leads to the correct responses to the questions asked in the activity. The teacher can use probing questions. By doing that, you will be promoting the critical thinking of your learners.
- It is most likely that most learners will come up with different observation, explanation, and description that are inaccurate.
- Use their feedback to trigger their curiosity in order for them to see the need of learn more from the unit.
- Encourage learners especially the slow learners that the correct answers will be obtained in the process of learning the unit so that by the end of it, they can be able to respond correctly to all questions asked in the unit focus activity.
- For slow learners, organise remedial lessons for them. Guide them through the activities and exercise once again and more slowly to help them understand.

### List of lessons

Lesson number	Lesson title	Number of periods
1.	Newton's first law of motion	1
2.	Linear momentum and impulse	2
3.	Newton's second law of motion (in terms of linear momentum)	2
4.	Newton's third law of motion	1
5.	Conservation of linear momentum	2
6.	Coefficient of friction	1
7	Unit assessment	1
	<b>TOTAL</b>	<b>10</b>

**Note:** Lesson 1 is allocated 2 periods to factor in the time for unit focus activity.

### Attention to special needs

In order to involve all learners in the learning process, you must know all your learners especially those with special need in your class.

- The unit comprises of numerous activities, you should involve the special need learners in these activities. For example, those activities that require use of legs they can use hand where necessary and vice versa or they can just observe and give their suggestion. Encourage the other student to appreciate suggestions of every student whether right or wrong.
- Some of the questions in the exercises can be given to gifted learners. Prepare additional more challenging questions for them learners. (See remedial questions for gifted learners at the end of this Teacher's guide unit)

### Lesson Development

#### Lesson 1: Newton's first law of motion

#### Learning objective

The learner should be able to explain inertia and the factors affecting it.

#### Teaching aids

- Table or bench
- A coin
- A smooth cardboard

#### Introduction to the lesson

Using question/ answer method, introduce the lesson by reviewing what the learners



learnt in Senior 1 Unit 4 on the Newton's first law of motion. Ensure that all learners are able to answer questions such as state Newton's first law of motion, what is inertia? What are factors that affect inertia? And so on, correctly. This is important for this section of the unit since most of the concepts to be learnt were already covered.

### Learning Activity

#### Teaching guidelines for activity 2.1

- Organise your learners into appropriate groups depending the availability of suggested learning materials. Ensure that the groups formed are gender sensitive (in case your class has boys and girls) and of different abilities. Working in groups will enhance **teamwork** and **cooperation** among learners.
- With your guidance, ask them to do activity 2.1, that is; to demonstrate inertia using a coin and a cardboard as provided in the student's book page 26.
- The activity may be enjoyable and amazing to the learners, but let them not lose the main focus of the activity i.e. the coin will resist any change of its resting state thus as the cardboard is moved, it leaves the coin behind and thus drops directly on the table.
- Let the learners discuss their observation from their activity. This will promote **communication skills** among your learners,
- Using their explanation let them now discuss the use of safety belts in vehicles. This will enhance **critical thinking** among the learners.
- Ask them to give a brief presentation on their finding to the whole class through their secretary. By doing so,

the confidence and **leadership skills** are enhanced in learners.

#### Synthesis

- Having done the activity, guide the learners through a class discussion on their finding. Guide them define Newton's first law of motion i.e. a body remains in its state of rest or uniform motion in a straight line unless acted upon by an external force. Emphasise that the law applies to both 'body at rest and in uniform motion' not at rest only or in uniform motion only.
- Let the learners know that the Newton's first law of motion is also known as the law of inertia.
- Take them through the discussion given in the student's book pages 27. Emphasis on the definition of inertia i.e. the property of matter to resist changes to its motion and give a real life example, for instance, passengers in a moving vehicle are lurch forward or backward when it starts or stops respectively, to bring the point home.
- At this point, let the learners understand the importance of wearing safety-belt in a moving vehicle, that is, to reduce any chances of serious injuries in case of an accident. Also use the picture given in student's book page 27 to sensitise them the potential and importance of everybody in the society whether you are a boy or a girl, Muslim or Christian. Condemn any kind of discrimination.
- Let them understand the factors affecting inertia of a body, that is: Mass of a body, acceleration of a body, force applied on the body and friction acting on the body.

## Assessment

Ask the learners to do exercise 2.1 given the student's book page 28.

### Answers to activity 2.1 student's book page 26

- In step 2, the coin and the cardboard are observed to be moving together.
- In step 3, the coil is left behind and it falls on the table.
- In steps 4 and 5, refer to the explanation in the discussion given in the student's book pages 27.

## Lesson 2: Linear momentum and impulse

### Learning objective

The learner should be able to describe linear momentum.

### Teaching aids

- Two hammers (light and heavy one)
- Two identical nails
- Wooden block
- pin
- wall
- ball

### Introduction to the lesson

The word "momentum" may be new to most learners. Introduce the lesson by asking learner to suggest what they think linear momentum is, its SI units and how it is denoted. This is important for the teacher to check whether the learners have any slight idea of what they are about to learn. Use their suggestions whether right or wrong to raise their curiosity and help them appreciate the need for them to discover and master the correct definition, SI units and the denotation of linear momentum.

Most learners may also find the word 'impulse' being unfamiliar. Introduce this section by allowing learners to suggest its definition. Note that some learners may try to check the answers from the student's book. Ask all of them to cross the textbook before asking them to attempt the definition. In addition, ask them question such as what are the two components of impulse? What is the difference between impulse and linear momentum? Allow learners to attempt to answer the questions. Use their suggestions (whether right or wrong) to trigger their curiosity in order for them to build interest to know more as they learn this part of the unit.

### Learning Activities

#### Teaching guidelines for activity 2.2

- In this activity, you may decide to use the groups formed in activity 2.1 or form the new groups. Note that when learners are working in groups, competences such as **cooperation**, **teamwork**, and **leadership skills** among others are enhanced.
- Let the learners do activity 2.2 in the student's book page 28, that is, to illustrate linear momentum. This activity involves the use of hands. Those learners who are physically disabled should be involve by being asked to observe keenly and contribute by giving their observations. If they are able, they can also be asked to record down the observations obtained from the activity. By doing so, you have ensured that all learners are involved in the learning activity.
- Allow them to discuss their findings from the activity. This will promote **teamwork**, **cooperation**,

**communication skills and critical thinking** among other competences in learners.

#### Synthesis

- Before concluding this section, hold a class discussion to ensure that the learners have mastered the following concepts:
1. Linear momentum is the product of the mass and the velocity of a body moving in a straight line.
  2. It is denoted by ' $p$ ' and its SI units are kilograms-metre per second ( $kg\ m/s$ ).
  3. Momentum is a vector quantity. Vector quantity has both magnitude and direction.
- Guide them through the discussion given in the student's book. Put more emphasis on the examples 2.1 and 2.2 in student's book pages 29-30. Ensure that learners have understood the calculation involving momentum in these examples. Help those with difficulty.

#### Assessment

Ask learners to do question 1 (a) of exercise 2.4 page 46. It is also good to create more questions from reference books to assess the learners in this section.

**N/B:** See answers for the Exercise 2.4 at the end of this unit of the Teacher's guide.

In addition, give them the following questions to assess whether they have understood this part of the unit.

1. If the speed and mass of an object are doubled, which of the following is true?
  - a) The momentum of the object is doubled
  - b) The kinetic energy of the object is doubled

- c) The momentum of the object is quadrupled
- d) The kinetic energy of the object is multiplied by 8
- e) The momentum and the kinetic energy of the object are quadrupled

#### Solution

$$p = m v$$

$$k = \frac{1}{2} m v^2$$

$M = 2 m$  and  $V = 2 v$  (mass and velocity doubled)  $P = M V = (2 m)(2 v) = 4 m v$  momentum is quadrupled.  $K = \frac{1}{2} M V^2 = ((\frac{1}{2}) (2 m) (2 v))^2 = (v^2 : \text{kinetic energy is multiplied by } 8)$

#### Answer: D

2. What is the momentum, in  $Kg\ m/s$  of a car of mass 1 ton moving at the following velocities
  - a)  $v_1 = 18\ km/h$  to the north
  - b)  $v_2 = 72\ km/h$  to the south
  - c)  $v_3 = 90\ km/h$  to the west

#### Solution

- a)  $p_1 = m V_1 = 1\ ton \times 18\ km/h = 1000\ kg \times 18\ 000\ m / (3\ 600\ s) = 5\ 000\ Kg\ m/s$  to the north
- b)  $p_2 = m v_2 = 1\ ton \times 72\ km/h = 1000\ kg \times 72\ 000\ m / (3\ 600\ s) = 20\ 000\ Kg\ m/s$  to the south
- c)  $p_3 = m v_3 = 1\ ton \times 90\ km/hr = 1\ 000\ Kg \times 90\ 000\ m / (3\ 600\ s) = 25\ 000\ Kg\ m/s$  to the west

#### Answers to activity 2.2 student's book page 28

- In step 2, when you hit the nail gently the penetration distance is small as compared to when you hit the nail very hard.

- In step 3, when you hit the nail with a heavy hammer the penetration distance is greater compared to when you hit the nail with a light hammer.
- In step 4, factors in which penetration depend include mass and velocity of the body.
- In step 5, refer to the discussion given in the student's book page 29.

### Impulse

#### Teaching guidelines for activity 2.3

- Organise the learners into appropriate groups depending on availability of the suggested materials in the student's book page 30. The teacher should always remember that it is good for learners to work in groups but those groups formed should reflect *gender balance* (in case of a class comprises of boys and girls) and different abilities (slow and faster learners).
- Ask learners to do activity 2.3 in the student's book page 30, that is, to demonstrate impulse using a ball.
- In step 2, ask them to press and withdraw the finger very fast.
- Guide the learners on how to remove air from a ball using the pin without destroying the inner tube of the ball.
- Allow them to discuss their observation from the activity. This will enable learners to realise the importance of *teamwork* and it will enhance communication skills in them.
- Go around to ensure that the main objective of this section (i.e. distinguishing between the impulse and linear momentum) is realised by learners.

- Ask the learners to report their findings through their secretary. Time may be insufficient, so let each group give a brief summary.

#### Synthesis

The learners having done the activity and reported their findings hold a class discussion to:

- Guide the learners through the discussion given in the student's books pages 30-31.
- Emphasise that:
  1. Impulse is the product of force and time.
  2. The SI unit of Impulse is Newton second
- Hold a discussion with the learners on a calculation involving impulse given in example 2.3 in the student's book page 31. Help those who may have difficulty.
- Discuss with the learners the difference between impulse and linear momentum given in the table 2.1 in the student's book page 31. At this point, the teacher should ask the learner to compare the difference given during the activity with the one in the table.

#### Assessment

Ask learners to do questions 2, 3 and 5 of exercise 2.2 in the student's book page 35.

**N/B:** See answers for the Exercise 2.3 at the end of this unit of the Teacher's guide.

#### Answers to activity 2.3 student's book page 30

- In step 2, the depression is seen on the point of contact. When the finger is withdrawn, the depression disappears

too. The force applied by the finger on the point of contact on the ball causes the depression. If the finger is pressed and withdrawn very quickly, the force will last for a short time.

- In step 3, the depression is seen on the point of impact. When the ball bounces back, the depression disappears. The force from the kick causes the depression and it lasts for a short time (impulse).
- In steps 4 and 6, refer to the discussion given in the student's book pages 30-31.
- In step 5, some of daily live examples where impulse is demonstrated include:
  - i. An arrow thrown by a bow: the rope makes a force proportional to the length it is pulled, just like a spring (Hook's law) propels the arrow. The more you pull the more force you need to do, like it is on a longbow. As the rope propels the arrow the force declines, and the impulse is the integral of the force.
  - ii. When you fall from a building and hits the ground your momentum varies to zero quickly, because a big force is applied to you in a short time when you hit the ground harming you, the variation of momentum is the same but the deceleration is bigger. If you use a bungee jump cord, a parachute, or over a stunt airbag, a smaller force is applied to you for a longer period saving your life. The same for car airbags, or for the car hitting a wall or using brakes.

- iii. If you hit a baseball or a golf ball correctly the bat or the club gets in contact with the ball for more time giving a higher impulse and consequently a higher momentum change and so a higher final velocity.

**N/B:** Accept any other appropriate examples given by learners.

### Lesson 3: Newton's second law of motion (in terms of linear momentum)

#### Learning objective

The learner should be able to state and explain the Newton's second law of motion in terms of linear momentum.

#### Teaching aids

- Two trolleys (Massive and light one)
- Spiral spring or a rubber band

#### Introduction to the lesson

In Senior 1, the learners defined Newton's second law of motion as follows:

The acceleration of an object as produced by a net force is directly proportional to the magnitude of the net force, in the same direction as the net force, and inversely proportional to the mass of the object.

This verbal statement can be expressed in equation form as follows:

$$a = \frac{F_{\text{net}}}{M}$$

The above equation is often rearranged to a more familiar form as shown below. The net force is equated to the product of the mass times the acceleration.

$$F_{\text{net}} = m \cdot a$$



In this entire discussion, the emphasis was on the *net force*. The acceleration is directly proportional to the *net force*; the *net force* equals mass times acceleration; the acceleration in the same direction as the *net force*; an acceleration is produced by a *net force*. It is important to remind the learners this distinction. Let them not use the value of merely “any ‘or force” in the above equation. It is the net force that is related to acceleration. The net force is the vector sum of all the forces. If all the individual forces acting upon an object are known, then the net force can be determined as learned in Senior 1. This is important because it will give a basis to the discussion in this section. In this unit, the Newton’s second law of motion is defined in terms of momentum. Therefore, stress on the ‘rate of change of momentum’ when the learners define it.

### Learning Activity

#### Teaching guidelines for activity 2.4

- Group the learners appropriately and prompt them to have a group secretary. It is upon the teacher to ensure that the groups comprises of *different abilities* and are of *gender balance* in case of a mixed class. This is important because it gives every learner *equal opportunity* to learn from each other. It also promotes *cooperation* and *teamwork* among them.
- Ask learners to do activity 2.4 in the student’s book pages 31-32, that is, to demonstrate and define Newton’s second law of motion in terms of linear momentum.
- Go through each group and ensure that they are doing the right thing.

- Allow them to discuss in their groups the questions and observation from the activity. This will promote *communication skills* and *critical thinking* among the learners.
- If the school has computers connected to Internet, ask them to do a researcher from the youtube site given in the student’s book to demonstrate Newton’s second law of motion. You may use a smart phone (in case there are no computers) to do a whole class demonstration to the learners. This part of research from Internet is important to the learners because it will promote *lifelong learning* and *ICT skills* in them.
- Ask learners to report to the whole class through the group secretaries.
- Hold a whole class discussion on their findings.

**N/B:** To understand this activity better and guide your learners well, visit the youtube website provided in the student’s book page 32 on the demonstration of Newton’s second law of motion prior to the lesson.

#### Synthesis

- Learners having done the activity, lead them through the discussion provided in the student’s book and help them to define Newton’s second law of motion as the rate of change of momentum is directly proportional to the resultant force and it takes place in the direction in which the force acts.
- Let them know that the relationship,  $F=ma$  shows that the greater the force applied the greater the acceleration.
- Let them understand that a newton is the force which when it acts on a mass of 1kg it gives an acceleration of  $1 \text{ m/s}^2$ .

- Discuss with the learners examples 2.4 to 2.8 given in the student's book pages 33-35 on the chalkboard.

### Assessment

Ask them to do questions 1, exercise 2.2 in the learner's book page 35, individually. Mark your learner's work and guide them accordingly. Let them do the remaining questions as homework.

**N/B:** See answers for the Exercise 2.2 at the end of this unit of the Teacher's guide.

### Answers to activity 2.4 student's book pages 31-32

- In step 4, the massive trolley moves slower than the light one. Because it has high mass hence lesser acceleration as compared to the lighter one.
- In step 5 and 6, refer to discussion given in the student's book pages 32 - 33.

## Lesson 4: Newton's third law of motion

### Learning objective

The learner should be able to state and explain Newton's third law of motion.

### Teaching aids

- Carton
- Cellotape
- 4 pins
- A large balloon
- A straw

### Introduction to the lesson

In Senior 1, learners learnt that, a force is a push or a pull that acts upon an object as results of its interaction with another object. They also learnt that some

forces result from interactions, that is, *contact interactions* (normal, frictional, tensional, and applied forces are examples of contact forces) and other forces are the result of action-at-a-distance interactions (gravitational, electrical, and magnetic forces). According to Newton, whenever objects A and B interact with each other, they exert forces upon each other. When you sit in your chair, your body exerts a downward force on the chair and the chair exerts an upward force on your body. There are two forces resulting from this interaction - a force on the chair and a force on your body. These two forces are called *action* and *reaction* forces and are the subject of Newton's third law of motion. Using question and answer method, discuss with learners some of these concepts they learnt. This is important because most of these concepts will be covered again in this section.

### Learning Activity

#### Teaching guidelines for activity 2.5

- Ask learners to organise themselves into appropriate groups depending on the availability of suggested learning resources. Go around checking whether the formed group according to the expectation, if not regroup them and emphasize the importance of observing gender balance (in case of a mixed class) and different abilities. This is important because it gives learners any opportunity to organise themselves hence promoting *organisational skills* in them.
- Ask them do activity 2.5 provided in the student's book pages 36-37, that is to demonstrate action and

reaction force. Through doing the activity together in groups, the learners will realise the importance of *teamwork* and *cooperation* in doing a particular task hence promoting these competences in them.

- Note that some learners may start playing with the balloon and lose the main objective of the activity, therefore it is important to go around the to all groups to ensure they are doing the right think. Help those who may need your assistance.
- Allow learners to hold a discussion on their findings and let the secretary note down the main points. Ensure that every learner is participating in the discussion. This is important because when learners give their views their *communication skills* and *critical thinking* is boosted.
- Ask the secretary from each group to give a summarised report on their discussion. Note that by doing so, you will be promoting *leadership skills* in learners.
- Lead them through the discussion and point out omissions or errors on each report given.

#### Synthesis

- The learners having done the activity, Summarise by taking them through the discussion given in the student's page 37-38 book. Emphasis on the definition of Newton's third law of motion i.e. For every action force, there is equal and opposite reaction force. It can also be stated as action and reaction forces are equal and act in opposite direction. The statement means that in every interaction, there

is a pair of forces acting on the two interacting objects.

- The size of the forces on the first object equals the size of the force on the second object. The direction of the force on the first object is opposite to the direction of the force on the second object.
- Forces always come in pairs - equal and opposite action-reaction force pairs. For instance, consider the flying motion of birds. A bird flies by use of its wings. The wings of a bird push air downwards. Since forces result from mutual interactions, the air must also be pushing the bird upwards. The size of the force on the air equals the size of the force on the bird; the direction of the force on the air (downwards) is opposite the direction of the force on the bird (upwards). For every action, there is an equal (in size) and opposite (in direction) reaction. Action-reaction force pairs make it possible for birds to fly.
- Take the learners through the practical example 2.9 given in the student's book page 38-39 to bring the point home.

#### Assessment

Ask learners to attempt all questions of exercise 2.3 provided in the student's book page 39.

**N/B:** See answers for the Exercise 2.3 at the end of this unit of the Teacher's guide.

#### Answers to activity 2.5 student's book pages 36-37

- In step 5, the trolley moves in the direction of the balloon.
- In step 6, the air comes out of the straw in the opposite direction of the movement of the trolley.



The law that governs the movement of the trolley is the third law of Newton that states that; “for every action force there is a reaction equal and opposite reaction force.”

### Lesson 5: Conservation of linear momentum

#### Learning objective

The learner should be able to describe linear momentum and its conservation.

#### Teaching aids

- A table
- Marbles
- Two trolleys
- Tapes
- A ticker timer
- Carbon papers
- A pin or a sharp buster rod
- A cork
- Runway
- Different masses (200 g and 300 g)
- A pin or a sharp buyyer rod

#### Introduction to the lesson

In Senior 1 and in this unit, learners have already learnt about the law of conservation of energy, momentum and impulse. Using question and answer method, ensure that learners are able to define and recall the following concept learnt correctly: The law of conservation of energy states that energy cannot be created or destroyed but is simply converted from one form into another, linear momentum as the product of mass and the velocity of an object and impulse is the change in momentum. Also, you may review activity 1.5 of unit 1 of the student’s book pages 10-11 to help learners to recall how the ticker timer in motion makes the dots on

the tape. These concepts are vital since they form the foundation of what the learners will be learning in this section of the unit.

#### Learning Activity

##### Teaching guidelines for activity 2.6

- Pairs up learners appropriately to do activity 2.6 given in the student’s book page 40. Note that working in pairs is considered due to the fact that the material suggested for this activity is likely to be sufficient and available. Also when learners work in small groups they benefit a lot from the activity than large groups.
- Ask them to do activity 2.6 provided in the student’s book pages 40. Go around to ensure that learners are doing the right thing. Help those with challenges.
- Give them few minutes to discuss their observation and come up with the law of conservation of linear momentum.
- Use their suggestions whether right or wrong to hold a whole class discussion on their findings.

##### Synthesis

- Now, having done the activity and discussed their results, guide them through the discussion provided in the student book pages 40-41.
- Let them know that momentum is mass in motion, and we can apply our understanding of outside forces here as well. Momentum can only occur when there is an outside force or impulse, not from within the system itself. This important concept is called the law of conservation of momentum. It describes how when there are no external forces, the momentum of a system doesn’t change.

- In equation form, momentum = mass  $\times$  velocity. To increase the momentum of an object, you need to increase its mass, its velocity, or both. This also means that different objects can have the same momentum. Say, for example, the marble is twice as massive as the other, but the second marble has twice the velocity. For both marbles, the product of mass and velocity is the same, so the momentum for both marbles is the same.
- When this happens to two marbles that are part of the same system, there is no net momentum, so we say that it is **conserved**. This means that there is no change in the overall quantity. If the momenta of the marbles are the same magnitude but opposite in direction, there will be no change in the net momentum of the system. They cancel each other out, just like internal forces.
- Summarise the discussion by stressing the following key points:
  1. *Total momentum before collision = Total momentum after collision*
  2. *The law of conservation of linear momentum states that when two or more bodies collide, their total momentum remains constant provided no external forces are acting.*
- Help them to understand and fill table 2.3 in the student's book page 42.
- Give learners few minutes to discuss their observations and results obtained from the activity. Ensure that all group members are participating in the discussion. Contributing to the discussion will promote *communication skills* and *critical thinking* among the learners.
- Ask the group secretaries to give a brief report to the whole class on their findings. By doing so, *leadership skills* and *communication skills* are enhanced in learners.
- Point out any errors or omission in each report given. At this point, let the learner know that it is always crucial to appreciate other student's views whether right or wrong and if they disagree, let them do so constructively. Hence they will be learning how to be tolerant to one another and therefore promoting *peace and harmony* among themselves.

#### Synthesis

Once you have discussed the report of the learners from the activity, let them understand the following facts:

#### Teaching guidelines for activity 2.7

- Organise learners into appropriate groups. Working in groups will promote *cooperation, interpersonal relation* among other competences.
- With your guidance, let the learners do activity 2.7 provided in the student's book page 42, that is, to demonstrate elastic collision.
- An elastic collision is defined as one in which there is no loss of *kinetic energy* in the collision.
- Total momentum before collision = Total momentum after collision.
- The assumption of *conservation of momentum* as well as the conservation of kinetic energy makes possible the calculation of the final velocities in two-body collisions.

- Discuss with them example 2.10 provided in the student's book pages 43 as you summarise and conclude the discussion on elastic collision of bodies.

### Teaching guidelines for activity 2.8

- Using the same groups used in activity 2.7, ask learners to do activity 2.8 given in the students book pages 44-45, that is, to demonstrate inelastic collision.
- Let the learners know that at the end of the activity everyone should be in a position to distinguish between elastic and inelastic collision.
- Guide them through the steps of the activity and if necessary, help them to fill the table 2.4 in the student's book page 44.
- Allow them to discuss their results and ask any learner from each group to report their findings. Picking learners at random will promote participation and keenness during the discussion.

### Synthesis

- Lead the learners through the discussion provided in the student's book page 45.
- Let them understand an inelastic collision is one in which part of the kinetic energy is changed to some other form of energy in the collision. Any macroscopic collision between objects will convert some of the kinetic energy into *internal energy* and other forms of *energy*, so no large-scale impacts are perfectly elastic. Momentum is conserved in inelastic collisions, but one cannot track the kinetic energy through the

collision since some of it is converted to other forms of energy, for example heat and sound energy.

- Discuss with the learners examples 2.11 to 2.12 given in the student's book pages 45-46 on the chalkboard. Help those who may have challenges of understanding the calculation involving inelastic collision.

### Assessment

Ask learners to do all questions in exercise 2.4 provided in the student's book page 46-47. Note that this exercise is crucial in assessing whether the concepts learnt in this section by learners have been understood. It is therefore important to mark their work and guide them appropriately.

**N/B:** See answers for the Exercise 2.4 at the end of this unit of the Teacher's guide.

### Answers to activity 2.6 student's book page 40

- In step 2, the first marble strike the adjacent marble and the process continues till the last marble got the stroke. They all start moving in one direction. The force from the person is transferred to the marble and from the first marble to the last. The total momentum of the marble remains constant provided no external forces are acting.

### Answers to activity 2.7 student's book page 42

- In step 6, initial velocity of the trolley is obtained by measuring the distance between the first three dots made on the tape before collision divided by the time of ticker time. For example, in the tape page 42 in the student's book, the distance between the three dots made on tape B before collision

is 0.8 cm. Divide 0.8 cm by 0.02 seconds if the ticker time used was of 50 Hz or by 0.01 seconds if it was of 100 Hz. Assume it was of 50 Hz, then the answer will be  $u_a = 40$  cm/s. The same method is used to determine other velocities required. Check whether the students have used the correct method. Note that for final velocity, they should measure the distance between the last three dots made by the ticker timer.

#### Answers to activity 2.8 student's book pages 44-45

- In step 9, initial velocity of the trolley is obtained by measuring the distance between the first three dots made on the tape before collision divided by the time of ticker time. For example, the tape in page 45 in the student's book, the distance between the three dots made on tape B before collision is 1.7 cm. Divide 1.7 cm by 0.02 seconds if the ticker time used was of 50 Hz or by 0.01 seconds if it was of 100 Hz. Assume it was of 50 Hz, then the answer will be  $u_a = 85$  cm/s. For final velocity, we measure the last three dots after collision and divide it by the time, that is 0.7 cm divide by 0.02s to get 35 cm/s. The velocity after collision is smaller than before collision.

### Lesson 6: Coefficient of friction

#### Learning objective

The learner should be able to describe the motion of objects in the horizontal plane with or without friction.

#### Teaching aids

- Solid block
- A spring balance
- Smooth and rough horizontal surfaces
- A rough bench
- A 50 g wooden block with rough surface
- Four 50 g masses

#### Introduction to the lesson

In Senior 1, learners were introduced to friction force as one type of force. They learnt that friction is a force that opposes the relative motion of two surfaces in contact. In Senior 2, they learnt about static and dynamic friction and how to determine them. Using question and answer method, review these and other concepts learnt. This is important since they form the basis of discussion on how to determine the coefficient of friction. Therefore ensure that they have understood them well.

#### Learning Activity

##### Teaching guidelines for activity 2.9

- You have already grouped the learners before when they were doing activity 2.8, you may decide to maintain the groups for this activity or form new groups. Forming new group sometimes is important because it help learners to interact and share new ideas from different learners. It also promotes *teamwork, cooperation* among them.
- Ask learners to do activity 2.9 provided in the student's book page 47- 48 ,that is, to describe motion of object on a horizontal plane with or without friction.

- Go around checking whether the learners are doing the right thing. Help those who may have difficulty in any step of the activity.
- Let them compare and discuss the difference ( if any) of the two forces they obtained from the activity. Ensure that every member in the group is participating. This will help in promoting communication skills in learners.
- Allow them to discuss their findings and go around to check their work and point out omissions and errors if any.
- This part of the unit will promote among other competences the:
  - i. Communication skills as learners share their ideas in a discussion on the coefficient of friction.
  - ii. Critical thinking as they tackle questions asked in a critical manner.

### Synthesis

Having done the activity, hold a class discussion to emphasis the following points:

- They are two types of friction force; static and dynamic friction force.
- Static friction is the kind of friction measured when the body on the surface is about to move.
- Dynamic friction also known as kinetic friction is the kind of friction force measured when the body has in relative motion. It opposes the motion.

### Teaching guidelines for activity 2.10

- Using the group used in activity 2.9, ask learners to do activity 2.10 given in the student’s book page 48 -49.
- With your guidance take the learners through the steps of the activity.
- Now allow them to do the activity on their own. And if necessary, help them to fill table 2.5 provide in the student’s book page 49.
- Let them use the data obtain in the table to draw a graph. Ensure that they apply the rules they learnt in unit 1 of this book on how to plot graphs.

### Synthesis

Ensure that the learners have understood the following concepts as your summarise their discussion:

1. A coefficient of friction is a value that shows the relationship between the force of *friction* between two objects and the *normal force* between the objects. It is a value that is sometimes used in *physics* to find an object’s normal force or frictional force when other methods aren’t available.
2. Frictional resistance to the relative motion of two solid objects is usually proportional to the force, which presses the surfaces together, as well as the *roughness of the surfaces*. Since it is the force perpendicular or “normal” to the surfaces, which affects the frictional resistance, this force is typically called the “*normal force*” and designated by N. The frictional resistance force may then be written:

$f_{\text{friction}} = \mu N$	$\mu$ = coefficient of friction $\mu_k$ = coefficient of kinetic friction $\mu_s$ = coefficient of static friction
-------------------------------	--

The frictional force is also presumed to be proportional to the *coefficient of friction*. However, the amount of force



required to move an object starting from rest is usually greater than the force required to keep it moving at constant velocity once it is started. Therefore two coefficients of friction are sometimes quoted for a given pair of surfaces - a coefficient of static friction and a coefficient of kinetic friction. The force expression above can be called the standard model of surface friction and is dependent upon several *assumptions* about friction.

- Take them through the discussion given in the student's book and emphasise the point that the coefficient of static friction is the ratio of static frictional force to the normal reaction.
- Guide the learners through the examples 2.13 and 2.14 given in the student's book page 51-52.

### Assessment

Ask learners to do question 18 provided in the unit Test 2 pages 53-56.

### Answers to activity 2.9 student's book page 47-48

- In step 3, the force measured when the solid block was pulled across the rough surface is greater than that on the smooth surface. It was easier to move the block across the smooth surface. This is because in smooth surface, the friction force is reduced.

### Answers to activity 2.10 student's book page 48-49

- In step 4, the reaction force should be recorded as shown.

Reaction force (N)	0.5	1.0	1.5	2.0	3.0
--------------------	-----	-----	-----	-----	-----

- In step 5, refer to the discussion given in the student's book pages 49-50.

### Summary of the unit

Summarise the unit by:

- Asking different learners to take the rest through different concepts highlighted in the unit summary given in the student's book page 52-53.
- Now, ask the learners to describe the solution to the problem faced during the unit focus activity at the beginning of the unit. After their respond, ensure that the learners are able to:
  1. Describe and explain what happens to the velocities of the balls in step 3, that is, Velocity of ball A is decreased and ball B is increased. Refer for explanation in the student book pages 25-26.
  2. Compare and explain the difference in velocities of ball B when a small ball C is used in step 4, that is, the velocity of produced by small ball on ball B is lesser than that of ball A. This is because small ball, C has less mass hence lesser momentum as compared to big ball, B.
  3. Give a correct answer to step 5, that is, Momentum and factors are mass and velocity.
  4. Explain how Newton's second law of motion govern the events during and after collision in step 6, that is, total momentum before and after collision remains constant when two bodies collide provide no external force act on them.
  5. Give a reason why the ball B slow down and eventually stops, that

is, because of friction force acting on the surface of the ball and the ground.

### Additional information to the teacher

It is important for the teacher to note the following:

- Momentum is a vector quantity; therefore the direction should be shown in its calculation. Most learners may just give answers without showing the direction. Emphasise the importance of showing the direction because they will be penalised for that.
- The SI unit of impulse is newton-second. It is small 'n' and not capital 'N' when writing in word. We use capital 'N' when writing in symbols, that is, 'Ns' and not 'ns'

### Lesson 7: Unit assessment

Ask the learners to do the Unit Test 2 given in the student's book pages 53-56. Hold a whole class discussion on their result and guide them appropriately.

### Remedial activities/ questions for slow learners

1. (a) Name three Newton's laws of motion.  
(b) Define each law named in (a)
2. State the SI unit for:  
(a) momentum  
(b) impulse
3. A car of mass 2 000 kg moves at a velocity of 80 m/s. Calculate its momentum.
4. State the law of conservation of the momentum.

5. A block of wood weighs 100 N. It is pushed along the horizontal surface by a force of 40 N. Calculate the coefficient of friction given that  $F = \mu R$ .

### Answers to activities/questions for slow learners

1. (a) First, second and third laws  
(b) Refer to student's book on how they state.
2. (a) kilogram-metre/second  
(b) newton-second
3. 160 000 kgm/s
4. When two or more bodies collide, their total momentum remains constant provided no external forces act on them.
5. 0.4

### Remedial activities/ questions for gifted learners

1. Discuss how Newton's first law of motion has improved the live of people.
2. Explain why heavy vehicles are not easily stopped when moving at high speed.
3. What does the area under the graph of Force (N) against time (s) represent? Explain.
4. A text book of mass 400 g is pushed across the table. The force applied to make the text book just to move is 1.2 N and to keep it moving, it requires 3 N. Calculate the static and kinetic coefficient of friction.
5. By giving real life example, explain what elastic and inelastic collisions means.



### Answers to activities/questions for gifted learners

1. The learner should be able to bring the concept of safety belt in his/ her explanation.
2. Because it has high momentum since momentum depends on two factors; mass and velocity.
3. Impulse. Since impulse = Force  $\times$  time
4. static coefficient = 0.3  
kinetic coefficient = 0.75
5. Mark learner's examples and explanation. Guide them appropriately.

### Answers to exercises and unit test

#### Exercise 2.1

(Learner's book page 28)

1. Property of matter to resist change to its state of motion.
2. Law of inertia is the Newton's first law of motion. It states that a body remains in its state of motion or uniform motion in a straight lines unless acted upon by external force.
3. To stop passengers from being ejected forward in case of an accident thus minimizing injuries on them

#### Exercise 2.2

(Learner's book pages 35-36)

1. (a) Newton's second law of motion states that the rate of change of momentum is directly proportional to the resultant force and it takes place in the direction in which the force acts.  
(b) Refer to the discussion given in the student's books pages 32-33

(c) The newton is a force which when it acts on a mass of 1 kg it gives it an acceleration of  $1 \text{ m/s}^2$

2. (a) Impulse of a force if the product of force and duration of the collision.  
(b) The impulse acting on the object is equal to the change in momentum it produces on the object  
(c) When the goalkeeper pulls back the hands while catching hard ball(s) the velocity of the ball is reduced gradually thus reducing the impact of the ball on the goalkeeper.

3. (a) Impulse = change in momentum  
 $= mv - mu$

Where  $m = 0.06 \text{ kg}$ ,  $v = 9.8 \text{ m/s}$   
and  $u = 58 \text{ m/s}$

$$\therefore \text{impulse} = (0.06 \times 9.8) - (0.06 \times 58) \\ = -2.89 \text{ kg m/s}$$

The negative sign shows that the ball was displaced vertically upward after lifting the racquet.

- (b) Impulse = force  $\times$  time

$$-2.89 = F \times 0.025$$

$$F = 115.6 \text{ N}$$

4. (a) 20 cm

(b) 5 N

5. Mass = 0.045 kg,  $v = 30 \text{ m/s}$ ,  $u = 20 \text{ m/s}$

Impulse = change in momentum

$$mv - mu$$

$$= 0.045 \times 30 - (-20 \times 0.045)$$

$$= 2.25 \text{ kg m/s}$$

6. 20 g

7. 1.5 mls

### Exercise 2.3

(Learner's book page 39)

- For every action force there is an equal and opposite reaction force
  - Propulsion of jets and rockets.
  - Rotation of the garden sprinklers.
- (a)** Rockets and jet propulsion use the reaction principle in that they accelerate mass in one direction and from Newton's third law of motion experience thrust in the opposite direction.  
**(b)** The garden sprinklers works on action and reaction principle-water moves out in the forward direction (action) and the sprinkler moves back (reaction)
- (a)** 400 mls  
**(b)** 150 N
- Force = mass x acceleration  
 $= m \times \left( \frac{v-u}{t} \right)$  where  $u = 0$ ,  
 $v = 250 \text{ m/s}$  and  $\frac{m}{t} = 150 \text{ kg/s}$   
 $= \left( \frac{m}{t} \right) (v-u)$   
 $= 150 \times 250$   
 $= 27500 \text{ N}$
- (a)** Refer to the students book fig. 2.10 page 38  
**(b)**  $2 \text{ m/s}^2$   
**(c)** 16 N
- (a)** Weight, Air resistance  
**(b)** Refer to learners book

### Exercise 2.4

(Learner's book page 46-47)

- (a)** Mass = 8 kg with velocity of 2.5 m/s  
Momentum = 8 kg x 2.5 m/s  
 $= 20 \text{ kg m/s}$

For mass of 2 kg with velocity of 30 m/s

$$\begin{aligned}\text{Momentum} &= 2 \times 3.0 \\ &= 6 \text{ kgm/s}\end{aligned}$$

- b)** Total momentum

Momentum before collision =  
momentum after collision

$$\begin{aligned}20 \text{ kg m/s} &+ -6 \text{ kg m/s} \\ &= 14 \text{ kg m/s}\end{aligned}$$

- Mass of moving object = 20 kg  
Mass of stationary object = 10 kg  
Velocity after collision = 5 m/s  
From law of conservation of momentum;  
Momentum before collision =  
momentum after collision  
 $(v \times 20 \text{ kg}) + (10 \text{ kg} \times 0)$   
 $= (20 + 10) 5 \text{ m/s}$   
 $V = 7.5 \text{ m/s}$
- Mass of car = 60 kg  
Speed of car = 20 m/s  
Mass of stationary pick up = 1200 kg
  - Momentum before collision  
= momentum after collision  
 $(600 \times 20) + (1200 \times 0) = (600 + 1200)v$   
Common velocity = 0.33 m/s
- Mass of track = 300 kg  
Speed of track = 3 m/s  
Mass of car = 600 kg  
Momentum before collision =  
momentum after collision  
 $(300 \text{ kg} \times 3 \text{ ms}) + (600 \text{ kg} \times -v) = 0$   
 $V = 1.5 \text{ m/s}$

5. Mass of ball = 2 kg  
 Speed of ball = 6 m/s  
 Speed of another ball = 4 m/s  
 Mass of the other ball = 4 kg  
 Speed of 4 kg ball after collision  
 = 5.5 m/s  
 Momentum before collision  
 = momentum after collision  
 $(2 \text{ kg} \times 6 \text{ m/s}) + (4 \text{ m/s} \times 4 \text{ kg})$   
 $= (5.5 \text{ m/s} \times 4 \text{ kg}) + (2 \text{ kg} \times v)$   
 Its speed decreases to 3 m/s

6. Mass of a small care = 500 kg  
 Mass of heavy car = 4 000 kg  
 Speed of heavy car = 20 m/s  
 Speed after collision = 4 m/s  
 Because after collision the two cars stick together thus may move with same velocity.

From law of conservation of momentum

$\therefore$  momentum before collision  
 = momentum after collision  
 $\therefore (500 \text{ kg} \times v) + (4\,000 \text{ kg} \times 10 \text{ m/s})$   
 $= (4\,000 + 500) 4 \text{ m/s}$

Speed of small car = 124 m/s

7. (a) 34 m/s  
 (b) 20 m/s

## Unit Test 2

( Learner's book pages 53-56 )

1. C  
 2. C  
 3. B

4. B

5. B

6. (a) The property of matter to resist change to its state of motion is called inertia which is Newton's first law

(b) When a moving bus comes to an abrupt stop the passengers lurch forward i.e. tend to keep moving on likewise when a bus surge forward, the passengers are jerked backwards i.e. tend to resist motion

7. (a) Ensure that the graph drawn by students has the correct scale and well plotted

(b) The value from the graph should have a very small error.

8. (a) Ensure that the diagram is drawn

(b) (i)  $204 \text{ cm/S}^2$   
 (ii) 150 N

9. (a) Impulse = force x time

time = 0.7 sec

force = 20 N

impulse =  $20 \times 0.7 = 14 \text{ NS}$

(b) The teacher should ensure that correct graphs are drawn, and the axes labelled and that kids have used the right scale.

10. (a)  $(2.0 \text{ kg} \times 1.5 \text{ m/s}) + (3.0 \text{ kg} \times 0.8 \text{ m/s}) = (2.013)v \Rightarrow v = 1.08 \text{ m/s}$

Both balls move at a velocity of 1.08 m/s

(b) Change in momentum

Change in momentum = Initial momentum – final momentum

For the 2.0 kg

$$\begin{aligned} \text{Change in momentum} &= (2.0 \times 1.5 \text{ m/s}) - (2.0 \text{ kg} \times 1.08) \\ &= 0.84 \text{ kg m/s} \end{aligned}$$

$$\begin{aligned} \text{For the 3 kg ball} \\ (3 \times 0.8 \text{ m/s}) - (3.0 \times 1.08) \\ &= 0.84 \text{ kg m/s} \end{aligned}$$

11. From the law of conservation of momentum

$$(75 \text{ kg} \times 8 \text{ m/s}) + (90 \text{ kg} \times 5.0 \text{ m/s}) = (90 + 75)v \Rightarrow v = 6.36 \text{ m/s}$$

$$\text{Common velocity} = 6.36 \text{ m/s}$$

12. (a) 45 N

(b)  $1.63 \text{ kg}^{-1}$

13. Mass of bullet = 15 g

$$\text{Speed of bullet} = 400 \text{ m/s}$$

$$\text{Mass of wood} = 300 \text{ g}$$

$$\begin{aligned} \text{Momentum of bullet} &= 0.015 \times 400 \\ &= 6 \text{ kg m/s} \end{aligned}$$

$$\begin{aligned} \text{Momentum of wood before collision} \\ &= 0.3 \times 0 = 0 \end{aligned}$$

By law of conservation of momentum

Momentum before collision = momentum after collision

$$6 \text{ kg m/s} + 0 = (0.3 + 0.015)v$$

$$\begin{aligned} \text{Velocity of wood after collision} &= \\ &19.04 \text{ m/s} \end{aligned}$$

14. Mass of bullet 20 g

$$\text{Speed of bullet} = 200 \text{ m/s}$$

$$\text{Mass of block} = 850 \text{ g}$$

$$(0.02 \times 200) + (2850 \times 0) = (0.02 + 0.85)v$$

$$4 = 0.87 v.$$

$$v = 4.6 \text{ m/s}$$

15. (a) 600 kg.m/s

- (b) 360 kg.m/s

- (c) 20 mls

- (d) Direction of block B

16. 35 mls

17.  $\mu_s = 0.275$

$$\mu_k = 0.175$$

18. (a) • Helps slow down moving objects as it acts in opposite direction, especially on slippery road.

- Helps in fixing nail on wood.

- Helps in writing using a pencil.

- (b) • Causes tear and wear in our shoes.

- Reduce motion of moving parts of a machine.

- Leads to bicycles rubber breaks to wear out.

- You can also mark other right answer provided by learners.

19. (a) F and f are the same the net force is zero.

- (b) F is greater net force moves the box to the left.

- (c) F is greater and is increasing as it moves.

- (d) F is greater and it is decreasing as it moves.

## Application of atmospheric pressure

Students book page 57-75 (10 Periods)

### Key Unit Competence

By the end of the unit, the learner should be able to explain the existence of pressure in gas and the application of atmospheric pressure.

### Prerequisite to this unit

For learners to acquire the knowledge, skills, altitude and values envisaged in this unit with ease, they need to have acquired the following:

- Knowledge on representation of a force as a vector, the identification of different types of forces in nature and the skills of measuring force using spring balance. These concepts were covered in S1 unit 3 on the topic of force (I). The teachers should establish through question and answer method whether the learners remember the concepts learnt before introducing the topic of application of atmospheric pressure.
- Knowledge on area of a surface and the skills of calculating the area. These concepts were covered in mathematics. The teacher should establish through question and answer method whether learners are able to describe area of a surface correctly.
- Knowledge on: definition and explanation of pressure in relation to surface area, explanation of how pressure varies with force and area of contact, definition and explanation of atmospheric pressure and its

applications, skills on how to measure atmospheric pressure using barometer, skills on how to solve equations using,  $P = \rho gh$ . These and many more concepts were learnt in *S2 units 6 and 7* on the topics of *density and pressure in solids and fluids and Archimedes principle and atmospheric pressure* respectively. The teacher should use small quiz or question and answer method or both to ensure that learners recall this basic knowledge learnt. This is important because most of the concepts to be covered in the unit will require well understanding of what they learnt as basic.

### Cross cutting issue to be addressed

The specific cross cutting issues to be addressed in the unit are:

- **Environment and sustainability:** Since the unit will involve the use of plastic container, mercury in a barometer and a vacuum cleaner, the attention of the learners at specific point within the unit is drawn to the importance of keeping our environment clean. The teacher should take the chance to emphasise the importance of keeping the places and the general environment where we live clean whether at school, home or anywhere else.
- **Financial education:** The use of coins in one of the activities in the unit to illustrate the existence of atmospheric pressure. The attention

of learners is drawn to the need of being good financial manager with the little finances they may have. This is important because learners will interact with money in their lives and if not well budgeted, it can bring conflicts with other people. The teacher should take this opportunity to sensitise learners on the need of being a good financial manager for their own benefit.

### Generic competences

The specific generic competences to be addressed in this unit include among others the:

- **Communication skills:** The competence will be achieved when the teacher ensure that all learners are participating by giving their views in a discussion of different learning activities given in the unit.
- **Teamwork, cooperation, personal and interpersonal management and life skills:** This competence will be achieved when the teacher organises the learners in groups to do different learning activities in the unit
- **Critical thinking:** This competence will be achieved when the teacher will involve learners in doing activities especially the unit focus activity and answering questions in the exercises 3.1, 3.2,3.4 and unit test 3 that require the learner to explain, discuss and describe the particular concept.
- **Research and Problem solving:** This competence will be achieved when the teacher involves learners in activities that require the use of internet and reference books to find solutions to the task given.

- **ICT:** This competence will be achieved when the teacher involves learners to do research from the internet. e.g when answering 3.1. learners will be able to learn how to use the internet as well as computers.

### Vocabulary /Keywords

In the course of learning the concepts in this unit, the learners will discover the meaning of the following new words:

- Magdeburg hemisphere
- Rubber sucker
- Automatic flashing unit
- Vacuum cleaner

Guide the learners to understand the apparatus named and their function in relation to physics concepts learnt.

### Guide on the problem statement

- For learners to have a general idea of what they will be learning in the activity, the teachers should allow them to do the unit focus activity on their own. The teacher will only be required to provide learners with the suggested learning materials.
- Organise learners into appropriate pairs or groups and provide them with the materials suggested (a glass, straw, cleaning drinking water, two beakers and delivery tube.) Once you have given them the materials (either in pairs or groups depending on the availability of materials) ask the learners to do the unit focus activity given in student's book pages 58-59.
- Allow learners to hold a discussion in their groups as they attempt to respond to all questions asked



in the activity. This will promote *cooperation, communication skills* and *leadership skills* among other competences in the learners.

- Use their feedback to guide them in such away that leads to the correct responses to the questions asked in the activity. The teacher can use probing questions. By doing that, you will be promoting the *critical thinking* of your learners.
- It is most likely that most learners will come up with different observation, explanation, and description that are inaccurate. At this point, show the learners the importance of accepting different opinions given by different learners whether right or wrong. This help to promote *peace* and *harmony* among the learners.
- Use their feedback to trigger their curiosity in order for them to see the need of learn more from the unit.
- Encourage those learners whom may have not responded correctly especially the slow learners that the correct answers will be obtained in the process of learning the unit so that by the end of it, they can be able to respond correctly to all questions asked in the unit focus activity.

### Attention to special needs

In order to involve all learners in the learning process, you must know all your learners especially the special need in your class.

- The unit comprises of numerous activities, you should involve the special need learners in these activities. For example, those activities that require use of both eyes and

hands, for example activity 3.1 in the student's book page 59, learners with sight challenges can use touch while those with disability of the hands (fingers or the hand as whole) can use their sight to observe and contribute during the discussion. Encourage the other student to accept and love learners with disability and not to threat them as those who are unable to participate in any learning activity. Remind learners that *disability is not inability*.

- Some of the questions in the exercises can be given to gifted learners. Prepare additional more challenging questions for them learners. (See remedial questions for gifted learners at the end of this Teacher's guide unit)
- For slow learners, organise remedial lessons for them. Guide them through the activities and exercise once again and more slowly to help them understand.

### List of lessons

Lesson number	Lesson title	Number of periods
1	Existence of atmospheric pressure	2
2	Factors influencing the atmospheric pressure	2
3	Instruments for measuring atmospheric pressures	2
4	Application of atmospheric pressure	2 1
5	Unit assessment	1
	<b>TOTAL</b>	<b>10</b>



## Lesson Development

### Lesson 1: Existence of atmospheric pressure

#### Learning objective

The learner should be able to explain the existence of force exerted by air on a surface.

#### Teaching aids

- A glass tumbler with water
- A cardboard

#### Introduction to the lesson

Learners already have an idea on what atmospheric pressure is and how to demonstrate its existence. Using question and answer method, introduce the lesson by reviewing what the learners learnt in Senior 2 Unit 7 on existence of atmospheric pressure. Ensure that all learners are able to answer and explain questions such as what is atmospheric pressure? How can you demonstrate the existence of atmospheric pressure? This is important for this section of the unit since they will be learning further on how the existence of atmospheric pressure and how to demonstrate it.

#### Learning Activity

##### Teaching guidelines for activity 3.1

- By now the learners should be able to organise themselves appropriately into different groups without your help whenever they are asked to do so. This does not mean you don't need to check and reorganise them where necessary. Therefore, organise them into appropriate groups depending the availability of suggested learning materials and let them be ready to do

activity 3.1. Working in groups will enhance *personal and interpersonal management, teamwork* and *cooperation* among learners.

- Ask the learners to do activity 3.1 in the student's book pages 59, that is, to illustrate the existence of atmospheric pressure using an inverted glass tumbler.
- Guide the learners through the activity and give them time to respond to the questions asked in the activity.
- Go around and listen how the student responds to the questions. Correct any wrong respond and guide them appropriately to understand the objective of the activity i.e. to illustrate the existence of the atmospheric pressure. By doing so, you will ensure all learners are participating by give their views hence promoting *communication skills* in them.

##### Synthesis

Before you ask the learners to do activity 3.2, ensure that they understand the fact that:

- The atmospheric pressure acting on the cardboard from outside is greater than the pressure due to the weight of water acting on the cardboard from inside hence the water in the glass tumbler does not flow when it is inverted.
- Guide them through the discussion given in the student's book to emphasise the fact given above.

##### Teaching guidelines for activity 3.2

- Using the same study groups used in activity 3.1, ask learners to do activity 3.2 in the student's book page 60.

- Guide them through the activity and let them discuss their observation within the group first, and then with other groups in the class. This is important since it will promote *communication skills, teamwork and cooperation* among other competences in the learners.
- Hold a whole class discussion on their findings and take the opportunity to correct any error or omission during the discussion.
- Let the learners give a reason why was it difficult to lift the coin during the discussion in the group. This is important because it will promote *critical thinking* and *communication skills* in learners.
- Summarise the activity by taking them through the discussion on their observations and discussion.
- At this point, draw the attention of the learners to the importance of being *a good financial manager* in managing any small finances that they may be getting (either from parents and guardians or personal sources) in appropriate manner.

### Synthesis

Summarise the discussion by:

- Asking the learners to refer to the discussion given in the student's book pages 60. Take them through the discussion and let them compare the facts discussed therein with what they obtained from the activity.

### Teaching guidelines for activity 3.3

- Still maintaining the same groups used in activity 3.2 or you may consider reorganise them, ask learners to do activity 3.3 in the student's book page 61. It is important learners to work in groups but appropriate one (i.e., gender sensitive and of different abilities). The groups should be as small as possible in terms of membership to reduce cases of some members not participating. This will promote *leadership skills, cooperation and teamwork* among the learners.
- Go around to ensure that everybody does the activity and give his/her observations to the group.

### Synthesis

- Learners having done the activity, emphasise the following fact that the water between the coin and the surface expel air reducing pressure under it, the atmospheric pressure now being great presses the coin towards the surface making it difficult to lift it.
- Conclude this section by taking them through the discussion given in the student's book page 61.

### Assessment

Learners having done activities 3.1 to 3.3 and understood the concepts of existence of atmospheric pressure, Ask them to work in groups of threes to do exercise 3.1 in the student's book as homework. It is important for learners to develop a culture of doing research by their own. This will enhance *research* and *problem solving skills* in them.

### Answers to activity 3.1 student's book page 59

- In step 2, the cardboard does not fall.
- In step 3, the cardboard does not fall.
- In step 4, the cardboard does not fall due to greater atmospheric pressure acting from outside on it than the pressure due to water acting on the cardboard from inside.

### Answers to activity 3.2 student's book page 60

- In step 3, the can is observed to shrink inwards.
- In step 4, refer to the discussion given in the student's book pages 58.

### Answers to activity 3.3 student's book page 61

- In step 3, there was no difficulty in lifting the coin
- In step 4, it was difficult to lift the coin up. Refer to the explanation given in the student's book page 61.
- In step 4, it should be noted lifting a coin without water underneath is easy as compared to when water is. In between the bench and the coin the explanation to this is given in learners book page 61.

## Lesson 2: Factors influencing the atmospheric pressure

### Learning objective

The learner should be able to discuss factors influencing the atmospheric pressure and relate it to density of air and altitude.

### Teaching aids

- Computers connected to internet
- Reference books

### Introduction to the lesson

In the previous section of this unit, the learners have learnt how to demonstrate the existence of atmospheric pressure. They should have appreciated the fact that indeed atmospheric pressure does exist and it is helpful. In S2 unit 4, the learners learnt how to measure atmospheric pressure using barometer. Through question and answer method or a small quiz, let the learners explain the variation of the height of the mercury as they were moving from one place to another on the process of measuring atmospheric pressure. This is important because most of the concept the learners will be learning require this basic knowledge. Therefore ensure that the learners have recalled what they observed and learnt before introducing this part.

### Learning Activity

#### Teaching guidelines for activity 3.4

- Organise learners into appropriate groups, that is, if the class is a mixed one, ensure you have the gender balance (i.e., equally number of boys and girls if possible) and also they are of different abilities. This will help learners to appreciate the factor that all students (whether boys or girls) should be *given equal opportunity* to learn and also to promote *cooperation* among them.
- Ask the learners to do activity 3.4 given in the student's book page 62.
- With your guidance, lead them through the steps of doing a comprehensive research on factors that affects the atmospheric pressure i.e. altitude, temperature, water vapour concentration and wind pattern from internet and reference

books. Note that some student may open different sites such as facebook, twitter and sports thus deviating from the main object of the research. It is therefore important to go around the class and check whether they are doing the right thing. Knowing how to do constructive research is important to learners since it will be promoting their *research and problem solving skills* that will be useful in their life time (*lifelong learning*).

- Give them few minutes to discuss their findings and let the group secretaries write down the main points from the discussion. This will promote *communication* and *leadership skills*.
- Hold a whole class discussion and ask the group secretaries to give the summarise report to the class. Use the opportunity to point out omissions and correct any error in each report presented.

#### Synthesis

Now hold a discussion with learners to emphasise the following facts:

- The factors that affect the atmospheric pressure include,
  - i. Altitude
  - ii. Temperature
  - iii. Water Vapour concentration
  - iv. Wind pattern
- Guide the learners through the discussion given in the student book page 62-64 on the factors affecting atmospheric pressure.

#### Assessment

Ask learners to attempt all questions in the exercise 3.2 in the student's book page

64. Ensure that you have marked their work and guide them appropriately where they have may have challenges.

**N/B:** See answers for the Exercise 3.2 at the end of this unit of the Teacher's guide.

#### Answers to activity 3.4 student's book page 62

- In step 1, factors affecting atmospheric pressure are altitude, temperature and wind pattern
- In step 2, refer to the discussion given in the student's book pages 62-64.
- In step 4, refer to the discussion given in the student's book page 62-63.

### Lesson 3: Instruments for measuring atmospheric pressure

#### Learning objective

The learner should be able to identify instruments used to measure atmospheric pressure and explain how they work.

#### Teaching aid

- Mercury barometer

#### Introduction to the lesson

In Senior 2 unit 7, learners learnt about the instruments for measuring atmospheric pressure. Using question and answer method, ask the learners to name two instruments for measuring atmospheric pressure. Let them draw their simple diagram and explain how they are used to measure the atmospheric pressure. Guide them to understand these concepts before introducing the section. This is important because most of concepts to be learnt by learners later in the section were learnt in S2.

## Learning Activity

### Teaching guidelines for activity 3.5

- Organise the learners into appropriate groups depending on the availability of the suggested material (mercury barometer) in the student's book pages 64-65. You should ensure that the mercury barometer is available for the activity, if not available, you can borrow one from neighbouring school. Remember that it is a good idea for learners to work in groups but those groups formed should reflect *gender balance* (in case of a class comprises of boys and girls) and *different abilities* (slow and faster learners). This is important because it will enhance *cooperation, teamwork* and *personal and interpersonal management* among learners.
- Before they start doing activity 3.5, bring to attention of learners that mercury barometer is *fragile* and *costly*, mercury is also *explosive* and *a pollutant*. They should therefore handle it with a great care.
- Now, ask learners to do activity 3.5 in the student's book pages 64-65, that is, to measure atmospheric pressure using mercury barometer.
- Guide the learners through the activity. Identify raised points and lower ones within the school compound and let them move with the mercury barometer to those points as they note any changes in the level of mercury in the barometer.
- Ask them to return back to class.
- Allow them to discuss their observation from the activity. This will enable learners to realise the importance of *teamwork* and it will enhance *communication skills* in them.

- Go around to ensure that the main objective of this section (i.e. to measure atmospheric pressure) is realised by learners.
- Ask the learners to report their findings through their secretary. Time may be insufficient, so let each group give a brief summary.

### Synthesis

The learners having done and reported their findings hold a class discussion to:

- Understand that at higher points, the level of mercury is less as compare to lower points this is due to decrease in atmospheric pressure acting on the surface of mercury at higher points as compared to lower points.
- Emphasise that mercury barometer, Fortin barometer and aneroid barometer are instrument used to measure atmospheric pressure.
- Guide the learners through the discussion given in the student's books pages 65-67.

### Assessment

Ask learners to do all questions in exercise 3.3 in the student's book page 67.

**N/B:** See answers for the Exercise 3.3 at the end of this unit of the Teacher's guide.

### Answers to activity 3.5 student's book pages 64-65

- In step 1, check the reading of the barometer and mark the recording of the learners. The reading should be recorded in accepted units such as mmHg, cmHg or mHg.
- In step 2, mercury has higher density than water hence it gives a reason length of glass tube to be used during construction of the barometer.



- In steps 4 the mercury level will drop due to decrease in atmospheric pressure.
- In step 5, refer to the discussion given in the student's book pages 65-67.

#### Lesson 4: Application of atmospheric pressure

##### Learning objective

The learner should be able to outline and discuss the applications of atmospheric pressure.

##### Teaching aids

- Drinking straw
- Glass with drinking water
- Flexible pipe
- Rubber sucker
- Empty beakers
- Syringe

##### Introduction to the lesson

In Senior 2 unit 7, learners were introduced to applications of atmospheric pressure. In this unit, they have also learnt other concepts such as existence and factors influencing atmospheric pressure. Using question and answer method inquire whether the learners recall these concept learnt well. Guide them where necessary to ensure that the explanation given by learners is correct. This is important because it lays a foundation on the discussion of applications of atmospheric pressure to discuss in this unit.

##### Learning Activity

###### Teaching guidelines for activity 3.6

- You have already grouped the learners before when they were doing activity 3.5, you may decide to maintain

the groups for this activity or form new groups. Forming new group sometimes is important because it help learners to interact and share new ideas from different learners. It also promotes *teamwork, cooperation* among them.

- Ask learners to do activity 3.6 provided in the student's book pages 67-68, that is, to describe the applications of atmospheric pressure.
- Go around checking whether the learners are doing the right thing. Help those who may have difficult in any step of the activity. The learner with *sight challenges* can be given the straw by the other learner and then helped to dip it in clean what before asked to suck. Note that you school provide learner with *clean drinking water* because some may drink it when asked to suck.
- With your guidance, allow them to discuss their findings for few minutes before asking the secretaries from each group to give a report to the whole class on their findings. This will promote *leadership* and *communication skills* in learners.
- Hold a class discussion on their findings and correct any errors ( if any) in each report given . At this point, help learners to realise the importance of *accepting other people's opinion* whether they are *right or wrong* and *in case they disagree, let them do so constructively*. This will promote *peace* and *harmony* among the learners.

##### Synthesis

- Having discussed learner's finding from the activities, now lead the

learners in the discussion given in the student's book pages 67-72 on the application of atmospheric pressure to verify their points. Assist them to understand how drinking straw, syringe, lift pump, siphon, automatic flushing unit rubber sucker and vacuum cleaner operates.

- At this juncture, draw the attention of learners into the importance of *keeping the environment we live in clean* all the time, that is to minimize the diseases associated with a dirty environment.

### Assessment

Ask learners to attempt all question provided in exercise 3.4 in the student's book page 73. Mark learner's work and guide them appropriately. This part will promote *critical thinking skills* among other competences.

### Answers to activity 3.6 student's book pages 67-68

- In step 2, water rises up the straw. When the straw was sucked, air was drawn from it leaving a partial vacuum. The atmospheric pressure acting on the surface of the water is now greater than the air pressure inside the straw hence the water rises up.
- In step 73, the water is drawn into the barrel of the syringe. Refer explanation given in the student's book 69.

### Summary of unit

- At random, ask different learners to lead others in brief discussion of different concepts highlighted in the unit summary given the student's book page 71. By asking them probing questions, help them recall the concepts.

- Ask learners to go back to the unit forces activity given on pages 58-59. Let them now give the correct solutions to the questions asked therein. Since the questions have been answered at one instance within the unit, help them to understand how to give correct answers. Let them understand that atmospheric pressure can be defined as the force exerted on the surface of the earth due to the weight of air column.

### Additional information to the teacher

It is important the teacher to know the following facts:

- With increase in altitude there is a decrease in atmospheric pressure. For every 110 cm of ascent there is a decrease of 1cm of mercury.
- A gravitational attraction exists between the mass of a planet or natural satellite and the gas molecules and particles in its atmosphere. The force of gravity tends to pull the molecules and particles toward the centre of the body. The weight of the atmosphere pushing down on itself and on the surface of the planet creates atmospheric pressure.

### Lesson 5: Unit assessment

Ask learners to do unit test 3 provided in the student's book pages 74-75 individually. Mark their work and hold a discussion on their results. This is important because it will help you as teacher to assess the *communication skills* when discussing the results and whether the learners have attained the objective of the unit. It will also help to promote *critical thinking* among them.



### Remedial activities/ questions for slow learners

1. What do you observe when the glass tumbler with water was inverted in activity 3.1 given in the student's book? What about when the thin can was corked in activity 3.2? What of when you sucked the straw dipped in water in activity 3.6? **N/B:** Let the learners give observations to these activities and many more in the unit while you ask the gifted learners to explain the observation. Later ask the slow learner to give explanation.
2. (a) Name three factors that affect atmospheric pressure of a place.  
(b) Name two instruments used for measuring atmospheric pressure.
3. Name two areas where atmospheric pressure is applied in our daily lives.

### Answers to questions for slow learners

1. Refer answers for specific activity under the title answer to activities given in this Teacher's guide unit
2. (a) Altitude, temperature and wind pattern  
(b) Mercury barometer, Aneroid barometer
3. When drinking soda using a straw, when a doctor uses an injection. Mark any other relevant answers given by the learners.

### Extended activities/ questions for gifted learners

1. Using reference book and Internet, design an activity not given in the student's book to demonstrate the existence of atmospheric pressure.

2. Discuss how atmospheric pressure is used to improve the well being of the people in Rwanda.
3. Explain how altitude and atmospheric pressure affects Rwandan athletes.

### Answers to the extended activities/ questions for gifted learners

1. Mark the student's work and guide them appropriately.
2. Refer to discussion given in the student's book under applications of atmospheric pressure. Let learners give variety of answers not necessary the one discussed in the student's book. Mark their work and guide them appropriately.
3. Refer to the discussion given in the student's book on factors influencing atmospheric pressure.

### Answers to exercises and unit test 3

#### Exercise 3.1

(Learner's book page 61)

#### Magdeburg Hemisphere

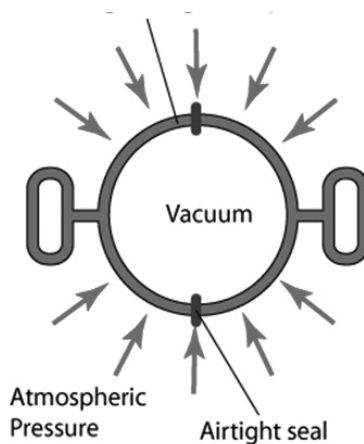

Fig. 3.1: Magdeburg Hemisphere

Figure 3.1 shows a Magdeburg Hemisphere. When the air inside the hemisphere is pumped out so that it becomes a vacuum, even a very great force cannot separate the hemisphere.

### Explanation:

The atmospheric pressure exerts a strong force on the outer surface of the hemisphere, holding the hemisphere tightly together.

### Exercise 3.2

(Learner's book page 64)

1. Altitude, wind pattern, temperature, water vapour concentration
2. At the top of the mountain there is low atmospheric pressure thus lowering the boiling point and thus the food takes long to cook.
3. Refer to discussion given in the student's book on how altitude affects atmospheric pressure and its effect to athletes.
4. Refer to the discussion given in the student's book on factors influencing atmospheric pressure.
5. Refer to discussion given in the student's book on how altitude affects atmospheric pressure and its effect to athletes.

### Exercise 3.3

(Learner's book page 67)

1. Mercury; it has a high density and a low melting point
2. By use of barometer. See discussion on different types of barometers used in learners book page 65-67.
3. (a) A mercury barometer works by measuring the height of the column of mercury in a

sealed tube and supported by atmospheric pressure while an aneroid barometer measures amount of distortion of a sealed metal can due to changes in atmospheric pressure.

- (b) A Fortin's barometer is a modified form of simple barometer, it has mercury and it is used in the laboratories to measure the atmospheric pressure while an aneroid barometer has no liquid, it can be carried from one place to another and it can measure the atmospheric pressure directly.

4. The tube of the barometer is tilted to the order and shaken several times to ensure the air bubbles are seen. Absence of air bubbles indicates a vacuum.

5. Atmospheric pressure = 740 mmHg

$$\text{Liquid pressure} = h\rho g$$

$$= 0.74 \times 13\,600 \times 10$$

$$= 1.064 \times 10^5 \text{ N/m}^2$$

6.  $= 1\,025 \text{ kg/m}^3$

$$p = 104\,000 \text{ N/m}^2$$

$$h = ?$$

$$p = h\rho g$$

$$104\,000 = 1\,025 \times h \times 10$$

$$h = 10.146 \text{ m}$$

### Exercise 3.4

(Learner's book page 73)

1. Sucking through a straw reduces the air pressure inside the straw. The atmospheric pressure forces the water into your mouth through the straw.
2. Refer the discussion given in the student's book

3. Refer the discussion given the student's book
4. Refer the discussion given the student's book
5. Compressed air in a force pump provides pressure that is used in the operation of the pump.

### Unit Test 3

(Learner's book page 74-75)

1. C.
2. B.

3. C.
4. Altitude, temperature, water vapour concentration, wind pattern.
12. Atmosphere, density, atmospheric barometer respectively.

**N/B:** For explanation of the questions in the unit test refer to discussion given in the student's book unit 3. It is also a good idea to refer to other reference books and Internet.

**Key Unit Competence**

By the end of this unit the learners should be able to differentiate between renewable and non-renewable energy sources and give examples.

**Prerequisites to this unit**

For learners to acquire the knowledge skills, attitudes and values envisaged in this unit with ease, they need to have acquired the following:

- Prior knowledge of energy. This unit was introduced to the learners in senior 1. Using the answer and question method, the teacher should establish that the learners remember these concepts before continuing with the unit.
- For some energy sources that are not found around or in the country, you can show them videos of how they are harnessed into other forms of energy or search from the internet.

**Cross cutting issues addressed in this unit**

- **Environment and Sustainability:** The unit is about energy sources which all of them have an effect of the environment. So the unit is drawn to the importance of keeping the environment clean.
- **Inclusive education:** All learners are included in the learning process

Generic competences addressed in this unit.

- Cooperation, interpersonal management and life skills through provision of group work
- Communication through provision of learner's discussion based activities.
- Critical thinking and problem solving through involving the learners in problem solving and discussion.

**Vocabulary/keywords**

In the course of learning the concepts in this unit, the learners will discover the meaning of the following new words:

- Wind power
- Fossil fuels
- Tidal barrage
- Solar panels
- Solar balloon

Guide the learners to understand the meanings of these words, try solving the problems related to them involving them in order to master their meaning and usage.

**Teaching methodologies**

- Group work
- Class discussion
- Question and answers
- Class demonstrations

## Guidance on the problem statement

In order to make learners give special attention into the general direction of the unit, the teacher should organise learner to do some discovery and guiding questions in groups. Remember they already know something about energy sources, such that they head to where you want them to be.

### Unit focus activity (page 77 learners book)

- Divide the students into small groups of between 3-4. Hand out a piece of paper to each group.
- Ask them to write down on a piece of paper the meanings of renewable and non-renewable sources of energy.
- Ask learners to write down at least eight sources of energy.
- Let them classify the sources of energy listed in step 2 as either renewable or non-renewable. Let them organise the classification in table.
- Ask them to discuss ways of conserving non-renewable sources of energy.
- Ask the learners to describe the energy transformations in a swinging pendulum and a loud speaker.
- Ask one person from each group to share their answers to the whole class

## Synthesis

- Allow the learners to hold a discussion in their groups as they attempt to respond to all questions asked in the activity. This will promote cooperation, communication skills and leadership skills among other competences in the learners.
- Use their feedback to guide them in such a way that leads to the correct responses to the questions asked in the activity.

- It is most likely that most learners will come up with different explanation, and description that are inaccurate, encourage the slow learners that the correct answers will be obtained in the process of learning the unit so that by the end of it, they can be able to respond correctly to all questions asked in the unit focus activity.

## Attention to special needs

In order to involve all learners in the learning process, you must know all your learners especially to the special need in your class.

- You should provide for learning of all learners including those with special needs.
- For the slow learners, organise remedial lessons where he/she guides them through the activities once again and more slowly to help them understand the concepts.
- Some of the questions in the exercise can be given to the gifted learners. Prepare additional and more challenging questions for learners. (See remedial questions for gifted learners at the end of this unit Teacher's guide).
- For slow learners, organise remedial lessons for them. Guide them through the activities and exercise once again and more slowly to help them understand.

## List of lessons

Lesson No.	Lesson Title	No. of periods
1.	Definition and Classification of Energy sources	1
2.	Classification and characteristics of energy	2
		2

3.	Energy transformations	2
4.	Unit Assessment	1
	<b>Total</b>	<b>10</b>

## Lesson Development.

### Lesson 1: Energy sources

#### Learning objective

By the end of this section, the learners should be able to define energy sources.

#### Teaching Aids

- A chart showing a picture of different sources of energy

#### Introduction to the lesson

- Using question and answer method, introduce the lesson by reviewing what the learners had studied in senior one unit 6 on work, power and energy. Ensure that all learners are able to answer questions correctly about energy, name some examples of energy sources and explain some found in Rwanda. Check their work to ensure that they have defined and explained the energy sources.

#### Learning Activities

##### Teaching guidelines for Activity 4.1.

- Ask the learners to do activity to 4.1 given in the student's book to identify and define energy sources as outlined on page 78.
- Ask them to use the chart to answer the questions.
- Ask them to give one general name to the objects seen in the chart.
- Ask them to discuss the meaning of the terms source and energy source.

Such discussion and presentation improves the communication skills of the learners.

#### Synthesis

- Having done activity and given the learners a chance to discuss in class, guide them to know that the word source means the beginning of something, and an energy source is a system which produces energy in a certain way. Some examples of energy sources are water, wind, the sun, geothermal sources, and biomass sources.

#### Answer to activity 4.1

- They are called sources of energy
- In step 3, a source is the beginning of something and an energy source is a system which produces energy in a certain way.

### Lesson 2: Classification and characteristics of energy sources

#### Learning objective

The learner should be able to classify and describe features of renewable energy and non-renewable energy sources.

#### Teaching Aids

- Reference books
- Internet,
- Convex lens
- Paper
- Scissor
- A sewing thread
- Light weight basket
- Small trash bag

## Introduction to the lesson

The word renewable source of energy is not new to the learners since they briefly studied it in senior one unit 6. Introduce the lesson through question and answer method to guide learners to review the definition and classification of energy sources as learnt in the previous lesson.

### Teacher guidelines for Activity 4.2

- Ask learners to do activity 4.2 to classify energy sources as outlined in the student book page 78.
- Ask them to distinguish between renewable and non-renewable sources of energy.
- Ask them to categorize the energy sources shown in Fig 4.1 in activity 4.1 on page 78 students book as either renewable or non-renewable sources of energy.

### Synthesis

Before concluding this section, hold a class discussion to ensure that the learners have mastered the following concept;

Renewable energy sources are energy sources that are continually replenished, while non-renewable sources are sources that will run out or will not be replenished in our lifetime or even in many years.

### Answers to activity 4.2

- In step 1, renewable energy sources are energy sources that are continually replenished while non-renewable sources of energy are energy sources that will not be replenished in our life time.
- In step 2, biomass, wind, water and sun are renewable sources of energy and fossil fuels-coal, propane, oil,

natural gas, petroleum, uranium, are non-renewable sources of energy

### Teacher guidelines for Activity 4.3

- Organise the learners into pairs. You should note that grouping learners in small groups increases their participation during their activity. It will also enhance personal and interpersonal management relation in learners.
- Guide them to do activity 4.3 given in the student's book on the definition and characteristics of renewable energy sources as outline in the student book page 79.
- Ask them to discuss in pairs to discuss the meaning of renewable energy sources, identify three characteristics of such sources and give three examples.
- Ask them to share their findings to the rest of the class. By presenting their findings to the rest of the class, nurtures their communication skills.

### Synthesis

Use a class discussion to help learners consolidate the facts in order to clearly understand;

- The definition of renewable sources as those sources that are continually replenished. Examples include solar and water sources.
- The characteristics of renewable sources as discussed in the student book page 79.

### Answers to activity 4.3

- In step 1, renewable energy sources are energy sources that are continually replenished. They exist infinitely.



- In step 2, some characteristics of renewable sources of energy include;
  - i. These resources are capable of regeneration.
  - ii. These are renewed along with exploitation and hence, always available for use.
  - iii. The regeneration of these sources involves some ecological processes on a time scale.
  - iv. The renewable sources become nonrenewable if used at a greater rate than the environment's capacity to replenish them.
  - v. These resources comprise materials like food, timber, raw materials for clothing's, leather.
- In step 3,
  - i) wind energy refers to the energy produced by wind. The wind is produced as a result of giant convection currents in the earth's atmosphere, which are driven by heat energy from the sun. This means that the kinetic energy in wind is a renewable energy resource: as long as the sun exists, the wind will too.
  - ii) Water energy; Moving water mainly produces energy in form of wave power, tidal barrage, and hydroelectric power.
  - iii) Solar power is energy from the sun. Without it, there will be no life. Solar energy is considered as a serious source of energy for many years because of the vast amounts of energy that is made freely available, if harnessed by modern technology

## Wind energy

### Learning objective

The learner should be able to define wind energy, outline advantages and disadvantages of using wind as a source of energy.

### Teaching Aids

- Reference books
- Internet

### Learning Activities

#### Teacher guidelines for Activity 4.4

- Organise the learners in pairs to do activities 4.4 as outline in the student book page 79-80. The activity is meant to help them appreciate the advantages and disadvantages of wind energy as an example of renewable source of energy.
- Encourage the learners to discuss their findings with rest of the class. Such discussion and presentation improves the communication skills of the learners.

### Synthesis

- Through a class discussion, help all learners to fully appreciate that the main advantage of wind energy is the fact that it is cheap and inexhaustible. The main disadvantage is the fact it leads to noise pollution.

### Answers to activity 4.4

- In step 1, the wind is produced as a result of giant convection currents in the Earth's atmosphere, which are driven by heat energy from the sun. This means that the kinetic energy in wind is a renewable energy resource: as long as the sun exists, the wind will too.

- In step 2, advantages of wind energy include it being a **renewable energy resource**, there are no fuel costs, and no harmful polluting gases are produced.
- The disadvantages of wind energy include wind farms being noisy and may cause noise pollution for people living near them. Also the amount of electricity generated depends on the strength of the wind. If there is no wind, there is no electricity.

#### Project work

- To help learners appreciate wind energy guide the learners through project 4.1 on the students book page 81.
- This will enhance their understanding on how wind energy works.

#### Water energy

##### Teaching Aids

- Reference books
- Internet

##### Learning Activities

##### Teaching guidelines for Activity 4.5

- Organise the learners in groups and ask them to do activities 4.5 as outlined in the student book page 82. The activity is meant to help them carry out a research on water energy.
- Ask learners to conduct a research on how electricity is generated using waves, tides and flowing water (HEP). Let them discuss the disadvantages associated with each one of them.
- Keep monitoring the learners to ensure that they are not distracted to visit other sites in the internet as others may want to go to social sites e.g facebook.

- Ask them to compare their findings with the rest of the class, and from what they will have discussed, make some corrections and help them make notes in their note books as given in the students' book 3.

#### Synthesis

Having done the activity, summarise the activity by letting the learners know that;

- Moving water mainly produces energy in form of wave power, tidal barrage, and hydroelectric power.
- Discuss the different forms of water energy as outlined in the student book page 82 and 83.
- Advantages and disadvantages of water energy as outlined in the student book page 84.

#### Answers to activity 4.5

- In step 1,  
Wave energy; the water in the sea rises and falls because of waves on the surface. **Wave machines use the kinetic energy in this movement** to drive electricity generators.  
Tidal barrage; A tidal barrage is a **barrier built over a river estuary** to make use of the kinetic energy in the moving water. The barrage contains electricity generators, which are driven by the water rushing through tubes in the barrage.  
Hydroelectric power (HEP); hydroelectric power stations use the kinetic energy in moving water. But the water comes from vast reservoirs behind a dam built across a river valley. The water high up behind the dam contains gravitational potential energy. This is transferred to kinetic energy as the water rushes down through tubes inside the dam.

The moving water drives electrical generators, which may be built inside the dam.

- In step 2, it has been difficult to scale up the designs for wave machines to produce large amounts of electricity. Tidal barrages **destroy the habitat of estuary species**, including wading birds. Hydroelectricity dams **flood farmland** and push people from their homes. The rotting vegetation underwater releases methane, which is a greenhouse gas.

## Solar energy

### Teaching Aids

- Convex lens
- Thin paper

### Preparation to the lesson

Before the lesson, prepare a set of the materials mentioned above for each of the groups you will work with, and choose a clear bright day with too much sunshine.

### Introduction to the lesson

The word solar energy is not new to the learners. Introduce the lesson by asking the learners to define solar energy. Ask them how it is harnessed to be of very good importance to people, like producing electricity.

### Learning Activities

#### Teaching guidelines for Activity 4.6

- Organise the learners in pairs to do activities 4.6 as outline in the student book page 85. The activity is meant to help them see solar energy at work by burning pieces of paper using a lens.
- Let them take care not to burn their skin with hot solar rays.

- Ask them to name devices that trap and store solar energy.

### Synthesis

- In a class discussion consolidate the observations in the activity to help learners qualify solar energy as a renewable sources of energy based on its characteristics. Guide them to appreciate the many uses of solar energy in our lives including helping us to see, lighting our houses using solar panels, photosynthesis, used in solar heaters etc.

### Answers to activity 4.6

- In step 4, after some minutes, the paper will be seen to burn. This is because the convex lens concentrates all the sun rays to one point increasing the intensity of the rays. The sun rays will end up burning the paper because of the heat from the rays.
- Take the learners through the discussion given in the learners book page 85 to make them appreciate solar energy.

## Solar thermal heaters

### Project 4.2

- Organise the learners and help them to do project 4.2 as outline in the student book 86-87. The project 4.2 is meant to help them to make a solar balloon.
- Let them take care not to cut their bodies with scissors.

### Synthesis

- In a class discussion consolidate the observations in the project 4.2 to help learner know how solar energy can be

used in many ways like making a solar balloon and solar thermal heaters as discussed in the student book page 86-88.

- Guide the learners through a discussion on the advantages and disadvantages of solar energy.
- Also guide the learners to discuss geothermal energy as outlined in the student book page 88.

### Assessment

Ask the learners to do exercise 4.1 in the student book page 89.

### Non-Renewable Sources

#### Learning objective

The learner should be able to describe features of non-renewable energy.

#### Learning Activities

##### Teaching guidelines for Activity 4.7

- Organise the learners into pairs.
- Guide learners to do activity 4.7 given in the student's book on the definition and examples of non-renewable energy sources as outline in the student book page 89.
- Ask learners to identify at least three characteristics and describe some three examples in our country.
- Summarise the activity by asking a member from each group to present to the class their findings. Such discussion and presentation improves the communication skills of the learners.

#### Synthesis

Use a class discussion to help learners consolidate the facts in order to clearly understand that:

- Non-renewable source of energy are sources that will run out or will not be replenished in our life time- or even in many lifetimes. Examples include; fossil fuels, coal, petroleum, and natural gas.
- The characteristics of renewable sources as discussed in the student book page 90.

#### Answers to activity 4.7.

- In step 1, non-renewable energy comes from sources that will run out or will not be replenished in our lifetimes or even in many, many lifetimes.
- In step 2, the characteristics of non-renewable sources of energy include
  1. They are available only in finite quantities and hence termed as "stock resources"
  2. They cannot be regenerated easily.
  3. They are concentrated as minerals usually in lithosphere of earth in a number of forms.
  4. They may be solids (coal, lignite, and minerals), liquids (petroleum) or gases (natural gases)
- In step 3, non-renewable energy sources include nuclear energy, coal, natural gas oil all which are called fossil fuels. Nuclear energy; the main nuclear fuels are uranium and plutonium. These are radioactive metals. Nuclear fuels are not burnt to release energy. Instead, the fuels are involved in nuclear reactions in the nuclear reactor, which leads to heat being released. Fossil fuels are mainly made up of Carbon. It is believed that fossil fuels were formed over 300 million years ago when the earth was a lot different in its landscape. It had

swampy forests and very shallow seas. The fossil fuels are coal, oil and natural gas. They are fuels because they release heat energy when they are burned. They have chemical energy stored within them.

## **Fossil fuels**

### **Learning objective**

The learner should be able to define fossil fuels and discover the extent to which the energy is consumed from fossil fuels.

### **Teaching Aids**

- Internet
- Reference books

### **Learning activities**

#### **Teaching guidelines for Activity 4.8**

- Provide a group of two students with a student's book; ask them to do activity 4.8 on page 90. The activity is meant to find out the extent to which fossil fuels are used, their advantages and disadvantages.
- Ask them to tell how many use kerosene, gas or none for cooking in their homes, and record it down. Let them in a class discussion identify the advantages and disadvantages of using fossil fuels as a source of energy.
- After the discussion for some minutes let each member present the outcomes from their discussion to the rest of the class. By each learner presenting to the class it helps them increase their communication skills.

### **Synthesis**

Before concluding this section, hold a class discussion to emphasise on the following concepts

- The origin of fossil fuels is 300 million years ago and are found usually in one location as their formation is from similar processes (see pages 88-89)
- Let them know that the main advantages of using fossil fuels is that they are relatively cheap and easy to obtain and that the main disadvantage is fossil fuels are non-renewable energy resources and that they release carbon dioxide when they burn, which adds to the greenhouse effect and increases global warming.
- Guide a discussion about the usage of fossil fuels in Rwanda as discussed in the book(see page 93)

### **Assessment**

- Ask the learners to do Exercise 4.2 given in the student book page 93-94.

### **Answer to Activity 4.8**

- In step 2, the main advantage of fossil fuels is they are relatively cheap and easy to obtain. While the disadvantages include they are non-renewable energy resources, they release carbon dioxide when they burn, which adds to the greenhouse effect and increases global warming, Coal and oil release sulphur dioxide gas when they burn, which causes breathing problems for living creatures and contributes to acid rain.
- In step 3, Fossil fuels release carbon dioxide when they burn, which adds to the greenhouse effect and increases global warming.



## Nuclear energy

### Learning objective

The learner should be able to be aware of the moral and ethical issues associated with using nuclear energy.

### Synthesis

- Through a class discussion, guide the learners through what nuclear energy means as discussed in the learners book page 94-95.
- Take learners through Fig 4.13 showing a nuclear power plant on page 95 students book.
- The main advantages of nuclear fuels is that nuclear fuels do not produce carbon dioxide or sulfur dioxide. The disadvantages of nuclear fuels that if there is an accident, large amounts of radioactive material could be released into the environment and nuclear waste remains are radioactive and hazardous to health.

### Assessment

- Ask the learners to do Exercise 4.3 given in the student book pages 96-97.

## Lesson 4; Energy Transformations

### Potential energy to kinetic energy and vice versa

#### Learning objective

The learner should be able to analyse transformation of energy into different forms.

#### Teaching Aids

- clamp and stand
- 1 m of string
- pendulum bob

- calculator
- Weighing scale.

### Introduction to the lesson

The learners have already encountered energy transformation in Senior 1. Introduce the lesson by asking learners to define energy transformations and state some examples of transformations.

### Preparation to the lesson

Before the lesson, make sure that the materials that are going to be used have been organised and ready.

### Learning Activities

#### Teaching guidelines for Activity 4.9

- Organise the learners into groups. It is better if you can change members or form new groups. Forming new groups sometimes is important because it help learners interact and share new ideas from different learners. This will promote togetherness, teamwork and cooperation.
- Guide them to do activity 4.9 given in the student's on demonstrating transformation of potential energy to kinetic energy and vice versa as outline in the student book page 97-98.
- Go around the class checking whether the learners are following the instructions stated to the later. Help those who may have difficulty in any step of the activity.
- Let them discuss in their groups where the pendulum has the greatest potential energy and where it has the greatest kinetic energy.
- Ask them to calculate the theoretical velocity at the bottom of the swing. This will help in promoting communication skills in learners.

### Synthesis

Having done the activity, hold a class discussion to emphasize the following points:

- Different groups have obtained different values of potential and kinetic energy from the use of different heights, and pendulum bobs having different masses.

### Answer to activity 4.9

- In step 7(a) the bob has greatest potential energy at the highest point.
- In step 7(b) the bob has greatest kinetic energy at the lowest point.
- In step 8 and 9, the values here vary. The teacher is advised to supervise every group carefully so that all the measurements can at least be accurate.

### Conversion of Electrical Energy into Mechanical Energy and vice versa.

#### Learning objective

The learner should be able to analyse transformation of energy into different forms.

#### Teaching Aids

- Safety pins
- Nails (screws)
- Battery holder
- Wood block
- Disk magnet
- Wire
- Scotch tape.

#### Learning Activities

##### Teaching guidelines for Activity 4.10

- Organise the learners into groups. It is better if you can change members or

form new groups. Forming new groups sometimes is important because it helps learners interact and share new ideas from different learners. This will promote togetherness, teamwork and cooperation.

- Guide them to do activity 4.10 given in the student's on making a simple motor as outlined in the student book page 99-100.
- Go around the class checking whether the learners are doing the right thing. Help those who may have difficulty in any step of the activity.
- Let them take care not to hurt their bodies with the knife, nails and safety pins.
- In case the motor does not work, ask them to repeat the procedures from the first one and mostly that of cutting the upper part of the wire not both parts.

### Synthesis

In a class discussion consolidate the observations in the activity to help learners know that an electric motor is a device that changes electrical energy into mechanical energy. Use this discussion to tell the learner that the motor is used in devices like electric fans, VCRs, CD players, computers, hair driers and others.

### Answers to activity 4.10

The teacher is advised to supervise every group carefully so that when the learners have a confusing step in the activity, the teacher can be near to help them.

In step 11 the motor converts mechanical energy to electrical energy.



## To demonstrate transformation of mechanical energy to electrical energy

### Learning objective

The learner should be able to demonstrate the transformation of mechanical energy to electrical energy.

### Teaching Aids

- Galvanometer
- Connecting wires
- Coil (solenoid)
- Bar magnet
- Insulated copper wire

### Learning Activities

#### Teaching guidelines for Activity 4.11

- Organise the learners into groups. This will promote togetherness, teamwork and cooperation.
- Guide them to do activity 4.11 demonstrating transformation of mechanical energy to electrical energy as outlined in the student book pages 100-101.
- Go around checking whether the learners are doing the right thing. Help those who may have difficulty in any step of the activity.

### Synthesis

Use a class discussion to explain to the learners that electromagnetic induction is the induction of an electric current in a conductor moving inside a magnetic field.

### Assessment

- Ask the learners to do an exercise 4.4 in the student's book on pages 101-103.

### Answer to Activity 4.11

The teacher is advised to supervise every group carefully so that when the learners have a confusing step in the activity, the teacher can be near to help them.

### Summary of Unit

Summarise the unit by:

- Asking different learners to state the different concepts highlighted in the unit summary given in the learner's book pages 103-104. Ask the class probing questions to help them recall the concepts correctly.
- Now ask the learners to describe the solution to the problem faced during the unit focus activity at the beginning of the unit. After their response, ensure that the learners are able to
  - i. Define an energy source.
  - ii. Classify different sources of energy as renewable and non-renewable sources.
  - iii. Explain the characteristics of renewable and non-renewable sources of energy.

### Additional information to the teacher.

It is important for the teacher to note the following;

- Sunlight is by far the predominant source of energy, and it contains a surprisingly large amount of energy. Virtually all the energy originates in the power of the atom. Nuclear reactions energize stars, including the sun.
- Primary source of energy is one that occurs naturally, e.g. fossil fuels, biofuels, wind, waves, solar radiation and nuclear fuels.

- A secondary energy source is one that is made using a primary resource, and can be generated by a number of different primary sources.
  - Coal is one of the best contributors to greenhouse gases and global warming. It emits more carbon dioxide than any other fossil fuel when it is burned. Making it worse, coal mining produces methane, a greenhouse gas with a global warming potential 25 times greater than that of carbon dioxide on a 100 year timeline. Giving information from student's book page 92.
3. The solar collectors have photovoltaic cells or PV devices which convert solar energy directly into electrical energy.

#### **Remedial activity for gifted learners.**

1. How do wind turbines work?
2. What is a wind farm?
3. Why is solar sometimes termed as the primary renewable energy?
4. Why is solar energy really a form of nuclear energy?
5. What is the difference between stored and instantaneous renewable energy?

#### **Remedial activity for slow learners.**

1. Explain giving examples what renewable energy is and why it is called 'clean energy' or 'green power'.
2. Why don't we use renewable energy all the time?
3. How do solar panels work?

#### **Answers to remedial activities/questions for slow learners**

1. Renewable energy is energy made from resources that can be renewed by Mother Nature. Examples include wind, water, sunshine and biomass.  
It is called clean energy because it does not produce harmful pollution.
2. Renewable energy is not there all the time, for example, we cannot store wind and sunshine to use if we need to make electricity. If the wind does not blow or if it does not shine, there would not be electricity from wind or solar energy.  
Also it costs more money to make electricity from wind for example than using natural gas.

#### **Answers for remedial activity for gifted students**

1. A wind turbines uses wind to make electricity. The wind turns the blades which spin a shaft, which connects to a generator and makes electricity. The electricity is sent through distribution lines to substations and then to places of consumption like homes.
2. It is a power plant made up entirely of wind turbines. They can be one or two or as many as 100. Its called a farm because they are usually found in the rural areas.
3. It is because it is the origin of many other energies. It is the most abundant renewable energy resource.
4. It is because the solar energy which arrives on the earth is part of a spectrum of radiation types emitted by thermonuclear fusion reactions which take place on the sun. This is the hydrogen bomb nuclear reaction. In this reaction, the deuterium atoms are combined to make helium plus energy.
5. Instantaneous renewable energy gets used right away and stored renewable

energy is stored before it can be used or such that it is used later at a stage when there is no supply.

### End of unit assessment

- Ask the learners to the Unit Test 4 given in the student book page 104-106

### Answers to Exercises and Unit Test

#### Answers to exercise 4.1 on page 89

1. Renewable energy is energy from a source that is not depleted when used. It is energy that is collected from renewable resources, which are naturally replenished. Such as wind, solar power, tides, waves and geothermal heat.
2. Renewable energy is preferable because of the following:
  - i) It is sustainable and so will never run out.
  - ii) Renewable energy facilities generally require less maintenance than traditional generators. Their fuel being derived from natural and available resources reduces the costs of operation.
  - iii) Renewable energy produces little or no waste products such as carbon dioxide or other chemical pollutants so has minimal impact on the environment.
  - iv) Renewable energy projects can also bring economic benefits to many regional areas as most projects are located away from large urban Centre's and suburbs of the capital cities.
3.
  - a) geothermal energy, solar energy
  - b) Infrared radiations.
  - c) Heat energy, electrical energy, light energy
  - d) Infrared radiation
  - e) drying clothes and food grains, used in lighting
  - f) black surface
  - g) solar cells
  - h) silicon and germanium
4. As the sun warms the earth's surface, the atmosphere warms too. Some parts of the earth receive direct rays from the sun all year and are always warm. Other places receive indirect rays, so the climate is colder. Warm air which weighs less than cold air, rises. Then cool air moves in and replaces the rising warm air. This movement of air is what makes the wind blow.
5. Characteristics of a source of energy include:
  - i) It should easily be accessible.
  - ii) It should be easy to store and transport.-most common sources of energy such as coal, petrol need to be transported to users from their points of production.
  - iii) It should be safe and convenient to use-energy sources should be safe as it is used by large number of people and should be convenient.
  - iv) It should be economical.
  - v) It should not leave residue after burning, i.e. it should burn completely
  - vi) It should burn without producing too many pollutants.

6. – Wood for cooking and heating  
– Wind and water for milling grain  
– Geothermal in hot springs for bathing to cure diseases.
7. Refer to work in the student book
8. Solar energy.
  - (i) Crop & slab engineer
  - (ii) Quality insurance manager
  - (iii) Wirw technology engineer
  - (iv) Production planner
  - (v) Laser operation technician
1. In the correct order. Dead Sea organisms, plants, animals, energy, sun's energy, photosynthesis, impermeable, matter, movements, shifts, well defined, technology, sea bed, and stored energy.
2. A
3. B
4. A
5. C
6. C
7. B

Answers to exercise 4.2 on pages 93-94.

8.

1. Petroleum (oil)		Black rock burned to make electricity
2. wind		Energy from heat inside the Earth
3. biomass		Energy from flowing water
4. uranium		Energy from wood, waste, and garbage.
5. propane		Energy from moving air
6. solar		Energy from splitting atoms
7. geothermal		Portable fossil fuel gas often used in used in grills
8. hydropower		Fossil fuel for cars, trucks, and jets
9. coal		Fossil fuel gas moved by pipeline
10. natural gas		Energy in rays from the sun

9. Fossils fuels such as oil, coal and natural gas formed by natural processes such as anaerobic decomposition of buried Dead Sea organisms, plants and animals containing energy originating in ancient photosynthesis. This happened a million years ago when the sea plants and animals could die, they could sink to the ocean floor where the anaerobic decomposition could take place. With time, sand and impermeable rocks settled on them trapping the energy within the porous rocks. This formed pockets of coal, oil and natural gas.
10. Fossil fuels are non-renewable because they are not or will not be replenished in our life time. They take a million years to be formed. This means the process of making them is slower than the process of consumption so they can easily get exhausted.
11. Burning fossil fuels puts carbon into the atmosphere. Fossil fuels provide most of the energy that supports human transportation and electricity. This adds enormous amounts of greenhouse gases to those naturally occurring in the atmosphere,

increasing the greenhouse effect and global warming. This emission increases the trapping of the sun's heat and stopping it from leaking back into the space.

**Answer to exercise 4.3 on page 96-97**

1. A
2. B
3. C
4. A
5. C
6. A
7. Fission, splitting, fusion, fused respectively.
8. See discussion given in students book page 94-95.
9. The deposit of the reactants that produces nuclear energy are finite.
10. i) Radioactive waste- the waste from nuclear power plants falls into two categories. High level waste is the left over fuel from the reactor after the reaction is finished, and it is extremely dangerous and can remain so for hundreds of years. Low level waste includes safety gear and incidental items that have picked up radioactive contamination but enough to remain dangerous to human life. Both types of waste require storage until the radioactive material decays enough to become harmless, requiring secure containment facilities that will last centuries
- ii) Nuclear accidents- this is an ecological danger that releases radiation. Some of the devastating

effects can show symptoms like diarrhea, vomiting, nausea and fatigue. People who work at nuclear power plants and live near those areas are at risk of facing nuclear radiations, if it happens.

- iii) High cost- this is another practical disadvantage of using nuclear energy is that it needs a lot of investment to set up a nuclear power station it is not always possible by the developing countries to afford such costly source of alternative energy.
- iv) National risk- nuclear energy has given us the power to produce more weapons than to produce things that can make the world a better place to live in. they are hot targets for militants and terrorist organization.
- v) Fuel availability- unlike fossil fuels, which are available to most of the countries, uranium, is very scarce resource and exists in only few countries.

**Answer to exercise 4.4 on page 101-103.**

1. B
2. A
3. B
4. B
5. D
6. B
7. Fill in answers in the right order.  
Chemical  
Kinetic  
Thermal  
Sound

8. i) bulb - electrical to light  
 ii) Guitar wire – mechanical to sound  
 iii) Athlete running – chemical to mechanical  
 iv) Candle – thermal to mechanical  
 v) Motor – chemical to light and thermal  
 vi) A battery in use – chemical to electrical  
 vii) Hot air balloon – thermal to mechanical
9. At the point of projection, the stone has maximum kinetic energy, as it moves up, it gains potential energy and kinetic reduces. At the highest point, it will have maximum potential energy and zero kinetic energy because it momentarily stops moving, then starts falling back. Amidst its falling back, it will have potential energy and kinetic energy and maximum kinetic energy when it reaches the initial point of projection and zero potential energy at the same point.
10. Mechanical energy in the rotating wheel is changed into electrical energy in the motor. The electrical energy will be converted to heat along the wire and the filament in the bulb and lastly light energy.

Potential energy of the water is changed into kinetic energy in the falling water and rotating turbines, heat and sound as the water falls on the turbines. The mechanical energy of the rotating turbines is changed into electrical energy.

**Answer to unit test on page 104-106.**

1. B                      6. E  
 2. A                      7. D

3. B                      8. D  
 4. A                      9. E  
 5. B                      10. B

**Discussion Questions**

11. The advantage of fossil fuels include;- fossil fuels are relatively cheap and easy to obtain, transporting oil and natural gas to the power stations can be made through the use of pipes making it an easy task.

The disadvantages of fossil fuels include;-

- i) Fossil fuels are non-renewable resources, that is their supply is limited and eventually can run out  
 ii) Pollution is the major disadvantage. When they are burnt, they produce carbon dioxide which adds to the greenhouse effect and increases global warming.  
 iii) Coal and oil release sulphur dioxide which causes breathing problems for living creatures and contributes to acidic rain  
 iv) Use of natural gas can cause unpleasant odors and some problems especially with transportation.  
 v) Environmentally the mining of coal results in the destruction of wide areas of land.
12. Fossil fuels are buried combustible geologic deposits of organic materials formed from decayed sea plants and animals a million years ago, that have been converted to crude oil, coal and natural gas by exposure to heat from continental drifts and pressure being under rocks and sand.



13. Fuel oil, gasoline and liquefied petroleum gas.

14. They are considered non-renewable because their formation is slower than their consumption. They take very many years to be formed which in people's life time can't happen.

15. The radiant energy transmutes into other forms, for example, it is the source of wind and water energy. That is to say, wind exists because the sun heats parts of the earth differently. As air masses warm and cool, wind results.

The sun's energy helps in the chemical reaction of photosynthesis in plants. The energy from sun passes from the plants to animals.

The oil and natural gas are the decomposed plants and animals of a million years ago. These lived because of energy from plants.

Electrical energy is changed by solar panels

All the above are all from solar energy.

16. The advantages of solar energy include;-

- i) It is a renewable source of energy so it will never run out
- ii) It has no fuel costs
- iii) No harmful polluting gases are

produced

The disadvantages of solar energy include;-

- i) Solar panels (cells) are expensive and inefficient.
- ii) Solar panels are useful on sunny days but not cloudy days.

17. Geothermal energy heat energy from the earth's crust. The sites where geothermal energy can be got from are not so easy to find.

18. Solar energy can be used to;-

- i) Solar hot water systems; they harness heat from the sun by capturing the sun's radiation using solar panel. The heat is used to heat water in the pipes which can be used for bathing
- ii) Solar photovoltaic cells;- these are devices that convert solar energy to electrical energy.
- iii) Solar energy can be used for sun bathing.
- iv) Solar energy can be used for drying crops, and clothes.

19. They all involve the turning of generators that produce the electricity.



# UNIT 5

## Heat Transfer and Quantity of Heat

Students book page 107-166 (9 Periods)

### Key Unit Competence

By the end of this unit, the learners should be able to evaluate mode of heat transfer and determine specific heat capacity of metal block.

### Learning objectives

#### Prerequisite to this unit

For learners to acquire the knowledge, skills, altitude and values required in this unit with ease, they should have acquired the following concepts.

- Knowledge on temperature and heat, the units of measuring temperature and heat (that is degree Celsius/

kelvin and joules. Knowledge on thermometers and the skills of reading the values from a thermometer. These concepts were learnt in S1. They are important for this unit since most of the discussion therein will require the application of what the learner have already learnt.

- Knowledge on behaviour of molecules of substances when heated and the skill of solving for unknown value in an equation. This is important because some of the question to be encountered in the unit requires the understanding of these concepts.

### Cross cutting issues to be addressed

Cross cutting issue	Addressing the issue	Outcome
Environment & Sustainability	Heating may be obtained from different sources of heat	The choice of source of heat should be that does not affect the environment and in sustainable e.g. new and renewal source. The teacher should take the opportunity to sensitize on the need of choosing a environmental friendly source.
Gender	Cooking involves heating. This is mostly associated with women	Encourage boys to also be involved in cooking. form groups where boys and girls work together
Peace and values	Encourage learners to work in groups of mixed gender and different abilities.	This brings peace and assurance that the life of learners is not at stake
Standard culture	Use standard methods of heat instrument	A Bunsen burner with all parts working should be used
Inclusive education	Involve all the learners in performing activities	Equip the labs such that no one is a spectator. Remind learners that <i>disability is not inability.</i>

### Generic competence

- *Teamwork, cooperation, personal and interpersonal management*- may be achieved by choosing groups in doing experiment.
- *Solving problems* within the unit will require critical thinking.
- *Communication skills*- It may be achieved when learners are asked to give their views over a particular concept within the unit.

### Vocabulary/ key words in the unit

*Key words*-Latent, convectional, radiation, thermostat, solar heater

*Vocabulary* – Smoldering, breeze, fusion

*Concepts*- Coefficient of expansion, heat capacity

Take a deliberate effort to explain to the learners and encourage them to practice to use them correctly.

### Guidance on the problem statement

In order to motivate learners and make them eager, attentive and active when learning the concepts in this unit, facilitate them to do the unit focus activity (Try this) outlined in the learner's book page 108.

### Teaching aids required

- Saucepan
- Electric coil

### Learning activity for unit focus

- Organise learners into appropriate groups. Prompt them to see the need of having a group leader and secretary. This will promote leadership skills among the learners.

- Ask the group leaders to lead their members in doing unit focus activity given in the student's book page 108.
- Allow learners to hold a discussion in their groups as they attempt to respond to all questions asked in the activity. This will promote communication skills and among other competences in the learners.
- Use their feedback to guide them in such away that leads to the correct responses to the questions asked in the activity. The teacher can use probing questions. By doing that, you will be promoting the critical thinking of your learners.
- It is most likely that most learners will come up with different identification, explanation, and description that are inaccurate. At this point, show the learners the importance of accepting different opinions given by different learners whether right or wrong. This help to promote peace and harmony among the learners.
- Use their feedback to trigger their curiosity in order for them to see the need of learning more from the unit.
- Encourage those learners whom may have not responded correctly especially the slow learners that the correct answers will be obtained in the process of learning the unit, so that by the end of it, they will also be able to respond correctly to all questions asked in the unit focus activity and the questionnaire given.

### Attention to special need

- The unit comprises of numerous activities, you should involve the special need learners in these activities. For example, those activities that require use of hands they can be assisted by others to observe and give their suggestion. Encourage the other student to appreciate suggestions of every student whether right or wrong.
- Some of the questions in the exercises can be given to gifted learners. Prepare additional more challenging questions for them learners. (See remedial questions for gifted learners at the end of this Teacher's guide unit)
- For slow learners, organise remedial lessons for them. Guide them through the activities and exercise once again and more slowly to help them understand.

### List of lessons

Lesson No.	Lesson title	Number of period
1	Heat and temperature	1
2	Modes of heat transfer	2
3	Thermal expansion	1
4	Quantity of heat	2 2
5	Unit assessment	1
	TOTAL	9

### Lesson development

#### Lesson 1: Heat and temperature

#### Learning objective

The learner should be able to recall differences between heat and temperature.

### Teaching aids

- Water
- Two identical test tubes
- A stirrer
- Measuring cylinder
- Cooking oil (about 200 g)
- Bunsen burner (source of heat)
- A beaker
- Two clamps and stand
- Two thermometers

### Introduction to the lesson

In S1 learners learnt about heat and temperature and its SI units, using the question answer method, ensure that they recall what they learnt before introducing this part of the unit. This is important because it will give learners a foundation to the concepts to be learnt in this section.

### Learning activity

#### Teaching guideline for activity 5.1

- Organize the learner into suitable groups to perform activity 5.1. This is important because it will enhance teamwork and cooperation among the learners.
- When they have formed the groups, ask learners to do activity 5.1 given in the student's book page 109.
- Develop a work sheet where the student should record their observation to avoid them filling in the book.
- Care must be taken for the learner not to burn their fingers. It is advisable to try this activity well in advance to know the safe quantity of water to heat.

- Allow learners to discuss their findings among themselves. This will promote communication and critical thinking skills.
- Hold a class discussion on their findings. Use the opportunity to point out errors in their findings as well as any omission.

### Synthesis

Through class discussion ensure that the learners understand the:

- Differentiate between heat and temperature, that is, Heat is a form of energy while temperature is the degree of hotness or coldness of a body.
- Units and instruments for measuring temperature and heat, that is,
  - i. Temperature-measured in Degree Celsius or kelvin
  - ii. Heat- measured in joules.
  - iii. Thermometer is the instrument for measuring the heat and temperature.

### Assessment

Ask learners to do question 1 of exercise 5.1 in the student's book page 122.

### Answers to activity 5.1

In step 3, the answer is NO. Refer to the explanation given in the student's book page 110.

## Lesson 2: Modes of heat transfer

### Learning objective

The learner should be able to explain the different modes of heat transfer

### Teaching aids

- A stirrer
- Water
- Source of heat
- A beaker
- Measuring cylinders

### Introduction to the lesson

- Use activity 5.2 given in the student's book page 110 to help the learners recall the three modes of heat transfer.
- Try and simplify the term "modes of heat transfer" e.g. methods or ways heat move through matter.

### Learning activities

#### Teaching guidelines for Activity 5.3

- Maintaining the same groups used in activity 5.1,ask learners to do activity 5.3 given in the student's book page 110, that is, to investigate heat transfer in solids.
- Guide them through the activity and let them discuss how heat is transferred by conduction.
- Go around the class listening to their discussion and help them where necessary. This will promote communication skills among them.
- Hold a discussion with learners to summarise their discussion.

### Synthesis

- Having done the activity and discussed their findings, emphasis the following facts:
- There are three modes of heat transfer; conduction, convection and radiation.

- Heat transfer by conduction and convection require a media while by radiation a media is not required.
- Conduction is energy transferred by vibration of the molecules. It takes place from a region of higher temperature to that of lower temperature.
- Let the learners realize that temperature difference or gradient (activity 5.3) is needed for heat to flow in a solid.

#### Teaching guidelines for Activity 5.4

- Using the same groups used in activity 5.3 or may consider regrouping the learners again. Working in groups will promote personal and interpersonal management and cooperation among learners.
- Once you have been satisfied with the groups the learners have formed, provide them with the suggested materials.
- Lead the learners through the steps of the activity and allow them to discuss their findings.

#### Synthesis

- Summarise the discussion by letting the learners to understand that a temperature difference or gradient is needed for heat to flow in solid.
- Guide through the discussion given in the student's book page 112 to clarify the findings from their discussion.

#### Teaching guidelines for Activity 5.5

- By now learners should be aware of forming suitable groups, that is, taking consideration of gender balance and different abilities of learners. Now organise them into suitable groups and provide them with the suggested materials to be ready for the activity.

- Ask learners to do activity 5.5 in the student's book page 112, that is, to show that heat transfer in solids depend on the material. The activity involves use of fire; great care must be taken by learners to avoid any incident that may be caused by fire if handled carelessly.
- Guide the learners through the activity and allow them to discuss their findings

#### Synthesis

Hold a discussion with learners to ensure they have understood that:

- Copper is good conductor of heat, followed by aluminum and iron in that order.

Lead them through the discussion given in the student's book to clarify the points.

#### Teaching guidelines for Activity 5.6

- Working with the same groups used in activity 5.5, ask learners to do activity 5.6 in the student's book page 113, that is, to observe convection current in water. Working in groups is important since it will promote teamwork and cooperation in learners.
- Guide them through the steps of the activity and allow them to do and discussion their findings on their own.
- Hold a discussion with the learners on their finds.

#### Synthesis

Having done the activity, hold a discussion with the learners to emphasise that convection is the heat energy transferred by the convection current in the liquid.

### Teaching guidelines for activities 5.7 and 5.8

- Organise learners into appropriate groups depending on the availability of suggested materials. Prompt them to see the need of having a group leader and the secretary.
- Ask the group leaders and the secretaries to lead their members to do activities 5.7 and 5.8 given in the student's book pages 114-115, that is, to illustrate convection in air and to illustrate that convection current possesses energy respectively. This will promote leadership skills, cooperation and teamwork among the learners.
- Allow the learners to discuss their findings among themselves. Listen how they discuss and guide them where necessary. This is important since it will give you opportunity to monitor and promote the communication skills of your learners.
- Go around to ensure that the main objectives of these activities, that is, to observe and illustrate that convection current possesses energy.
- Hold a whole class discussion and ask the group secretaries to give the summarised report to the class. Use the opportunity to point out omissions and correct any error in each report presented.

### Synthesis

- The learner having done the two activities (5.7 and 5.8), let them understand the fact that heat is transferred in air through convection current. This convection current possesses energy.

### Teaching guidelines for activities 5.9, 5.10 and 5.11

- Organise learners into appropriate groups, that is, if the class is mixed, ensure you have the gender balance (i.e., equal number of boys and girls, if possible) and also they are of different abilities (slow and gifted learners). This will help learners to appreciate the fact that all students (whether boys or girls) should be given equal opportunity to learn and also to promote the sharing of ideas and cooperation among them.
- Ask the learners to do activities 5.9 to 5.11 given in the student's book pages 116-118, that is, to demonstrate heat transfer by radiation, to illustrate good and bad absorbers and to illustrate good and bad emitter respectively.
- With your guidance, lead them through the steps of doing the activities.
- Give them a few minutes to discuss their findings and let the group secretaries write down the main points from the discussion. This will promote communication and leadership skills.
- Hold a whole class discussion and ask the group secretaries to give the summarised report to the class. Use the opportunity to point out omissions and correct any error in each report presented.

### Synthesis

Hold a class discussion with learners to emphasize the following facts:

- Radiation is the emission or transmission of energy in the form of electromagnetic waves or particles.



- Radiation involves the method of transferring heat without contact or in a vacuum.
- A dull black surface is a good absorber while a shiny one is bad absorber
- A dull black surface is a good emitter of heat while a shiny surface is a bad one.

### Assessment

Ask learners to do questions 2-6 of exercise 5.1 given in the student's book page 122.

### Answers to activity 5.2 learner's book page 96

Mode of heat transfers is conduction, convection. Refer to the discussion given in the student's book for the difference.

### Answers to activity 5.3 learner's book page 110

In step one, the wax melts and you feel warmth when you touch the spoon.

In step 2, refer to the discussion given in the student's book.

### Answers to activities 5.4, 5.5, 5.6, 5.7, 5.8, 5.9, 5.10 and 5.11 learner's book pages 108-116.

Refer to the discussion given in the student's book on the mentioned pages.

### Application of heat transfer

#### Learning objective

The learner should be able to state the application of heat transfer

#### Teaching aids

- Vacuum flasks
- Ventilators in building charts or photographs
- Electrical devices
- Hot water system

- Solar heaters
- Solar concentrator

### Introduction to the lesson

Learners have interacted with vacuum flask, they have seen ventilation on their houses, they may have seen solar heater and domestic water system. Through question and answer method inquire whether the learners have any idea on each of them. Use their suggestions whether wrong or right to introduce this part of the unit. This is important because it will raise the curiosity of learners to understand each of them well.

### Learning activities

#### Teaching guidelines for 5.12

- Organise learners into appropriate groups, that is, if the class is mixed, ensure you have the gender balance (i.e., equally number of boys and girls, if possible) and also they are of different abilities (slow and gifted learners). This will help learners to appreciate the factor that all students (whether boys or girls) should be given equal opportunity to learn and also to promote the sharing of ideas and cooperation among them.
- Ask the learners to do activity 5.12 given in the student's book pages 118-119, that is, to carry out a research on the applications of heat transfer.
- With your guidance, lead them through the steps of doing a comprehensive research on application of heat transfer. Note that some student may open different sites such as Facebook, twitter and instagram thus deviating from the main object of the research. It is therefore important to go around

the class and check whether they are doing the right thing. It is very important for Learners to know how to do a constructive research by their own since it will be promoting their research and problem solving skills that will be useful in their life time (lifelong learning).

- Give them few minutes to discuss their findings and let the group secretaries write down the main points from the discussion. This will promote communication and leadership skills.
- Hold a whole class discussion and ask the group secretaries to give the summarise report to the class. Use the opportunity to point out omissions and correct any error in each report presented.
- Use field trips to show the learners more devices that apply heat transfer and are not available near your school

#### Synthesis

- In the devices used to show the application of heat transfer, allow the learners to explore how the 3 modes of heat are employed
- Emphasize on which mode is predominantly used and why. Refer to the discussion given in the student's book for explanation.
- Guide the learners through the discussion given in the student's book on applications of heat transfer.
- Choose one device e.g solar heating and develop a project engage all the learners in this project

#### Assessment

- Mark the projects as a sign of understanding of the application of heat transfer
- The marking scheme should show the acquisition of knowledge, skills and attitude envisaged in the syllabus.
- In addition, ask the learners to do question 7 of exercise 5.1 given in the student's book page 122.

#### Answers to activity 5.12 learner's book pages 118-119

- In step 1, refer to the discussion given in the student's book.
- In step 4, mark the student's work and guide them appropriately.

#### Lesson 3: Thermal expansion

The learner should be able to;

- i. Explain thermal expansion of solids
- ii. Solve problem related to expansion

#### Teaching aids

- Bar and gauge apparatus
- Bimetallic strip
- Ball and ring
- Electric iron box

#### Introduction to the lesson

In senior 1, learners were introduced to temperature and heat. They learnt about thermal equilibrium. Using question answer method, establish whether they still recall what they learnt. Build on their foundation by asking them the probing question such as what is thermal expansion? What do you think it is important to learn about thermal

expansion? This is important for laying a foundation towards learning the concepts in this section.

#### **Teaching guidelines for activities 5.13, 5.14, 5.15 and 5.16**

- Organising learners into suitable groups to perform activities 5.13, 5.14, 5.15 and 5.16 in a rotation basis.
- You may consider making a trip to a railway tracks near or far from your school with your students. Identify the rail, gap rigid support and fishplate. Let the students suggest why they are there.
- Allow the learners to report their finding to class.
- Hold a class discussion on their finding from each activity.

#### **Synthesis**

- In S1, we learnt that the molecules in solid are closely packed and are in continuous vibration about a fixed position. Use this to help the learners explain why solids expand on heating
- Use model of marbles in a tray to also explain the behavior of molecules in solids.
- Allow the learners to discuss the application thermal expansion
- Emphasize that when you are talking about expansion, contraction is implied i.e. heating and cooling usually go together.

#### **Assessment.**

- Discuss with learners Example 5.1, 5.2, 5.3 and 5.4 in the student's book on the chalkboard to explain the coefficient of expansion.

- Give exercise 5.2 given in the student's book page 130 as take away assignment. Mark and use it to judge the learners competence use.

#### **Answers to activities 5.13, 5.14, 5.15 and 5.16**

Refer to the discussion given in the student's book after each activity.

#### **Teaching guidelines for activities 5.17, 5.18 and 5.19**

- The teacher may do these activities as additional activity. Therefore the he / she may decide to maintain the groups formed earlier.
- Ask them to do activities 5.17-5.19 in the student's book pages 131-134.
- Lead the learners through the activities.

#### **Synthesis**

Having done the activity, hold a discussion with learners on the concepts discussed in the student's book after each activity.

#### **Answers to activities 5.17, 5.18 and 5.19**

Refer to the discussion given in the student's book after each activity.

#### **Teaching guidelines for activities 5.20**

- Organise the learners into appropriate groups depending on the suggested materials in the student's book page 132. The teacher should always remember that it is good for learners to work in groups but those groups formed should reflect gender balance (in case of a class comprises of boys and girls) and different abilities (slow and faster learners).
- Ask learners to do activity 5.20 in the student's book page 132, that is, to conduct a research on expansion and contraction.

- Guide the learners on how to conduct a research from Internet. Note that some learners may open different sites from the expected one; therefore it is important for the teacher to go around and guide them properly. This will promote research skill in learners.
- Allow them to discuss their observation from the activity. This will enable learners to realise the importance of teamwork and it will enhance communication skills in them.
- Go around to ensure that the main objective of this section (i.e. Able to highlight and explain dangers associated with power generation and transmission) is realised by learners.
- Ask the learners to report their findings through their secretaries. Time may be insufficient, so let each group give a brief summary.

#### Answers to activities 5.20

Refer to the discussion given in the student's book after the activity.

#### Assessment

- Ask learners, to do activity 5.21 to explain applications of heat transfer.
- Give exercise 5.3 as take away assignment. Mark and use it to judge the learners' competence use.

### Lesson 4: Quantity of heat

#### Learning objective

The learner should be able to;

- Define heat capacity
- Define specific heat capacity
- Define specific latent heat of vapourization and fusion

- Describe experiments to determine specific heat capacity

#### Teaching aids

- Calorimeter (complete)
- Ammeter
- Voltmeter
- Variable resistor
- Immersion heater
- Stop watch

#### Introduction to the lesson

- Use activity 5.22 in the student's book page 138-139 to introduce the lesson.
- Let the learners realize that cold substances absorb heat energy while hot ones lose heat energy.
- Declare that, this section deals with a measure of capacities of substances to gain or lose heat energy.

#### Learning activities

#### Teaching guidelines for activities 5.23

- Now, organise the learners in groups to perform activity 5.23 in the student's book page 139.
- Through probing question and results in activity 5.23, guide the learners to develop an equation of calculating quantity of heat i.e  $Q = mc\Delta\theta$ .

#### Synthesis

- Hold a discussion with learners on examples 5.4, 5.5, 5.6, 5.7, 5.8, 5.9 on the chalkboard that gives the practice on the heat energy lost or gained.
- Through the above activities, question and answer method help the learners to realize;  
 $Q = mc\Delta\theta$ .

- Ask the students to practice examples after every lesson.

#### Assessment

- Insist that after every lesson learners should do the relevant exercise. Exercise 5.4 and 5.5 given in the student's book pages 141-143 respectively.

#### Answers to activities 5.22 and 5.23

Refer to the discussion given in the student's book.

#### Teaching for activities 5.24-5.25 (pages 143-145)

- In each activity, ensure that you have grouped learners into convenient pairs, small groups or large one depending on the availability of the suggested materials. It is good idea to reorganise the groups after every activity or two if you think it is important to do so.
- Let them choose group leader and secretary who will be leading them through the activities.
- In each activity, provide learners with the materials suggested in the student's book on each of them.
- Every time, ask learners to do the activity and discuss their finding within the group.
- Once they finish the activity, ask the secretaries to give a brief summary on their findings to the whole class.
- Guide them through the discussion on their findings appropriately.

#### Synthesis

Learners having done the activity hold a constructive and discuss the facts given in the student's book after every activity from activity 5.26 to 5.27. This is important because it will help learners to see errors on their finding and correct them hence enabling them to understand the concepts required in each section.

Hold the discussion on the use of the equation  $Q=mc\Delta\theta$ ,  $Q=ml_f$  and  $Q=ml_v$

Discuss examples 5.8 to 5.11 with learners on the chalkboard. Help those who may have challenges in any part of calculation.

#### Assessment

Ask learners to do exercises 5.6 after they have done and discussed activities 5.24-5.25 and exercise 5.7 after they have done and discussed activities 5.26 to 5.31 and the discussion given there after in the student's book.

#### Summary of the unit

- Organize learners into groups and give the each some points in the summary of the unit and let them discuss and report to the class
- Let the groups also identify vocabulary, key words and concepts that are main areas of achieving the learning objectives.

#### Additional information

Heat activities are sources of danger to the learners. Be alert all the time. Make sure you have first aid kit, firefighting equipment (that are working) to address the dangers posed by heating of thing.

## Unit assessment

Unit 5, combines many concepts that are related to heat. We have deliberately given many questions to cover the unit successfully use different methods of teaching to ensure learners benefit from unit test 5

### Remedial activities/ Questions

Not all learners have the same ability in understanding concepts in this unit. Think of many activities depending of the concept involved and the level of your learners.

In addition, let them attempt the following questions

Where necessary take

specific heat capacity of water = 4 200 J kg<sup>-1</sup> K<sup>-1</sup>

Ice = 336 000 J kg<sup>-1</sup>

Water = 2 260 000 J kg<sup>-1</sup>

density of ice = 900 kg/m<sup>3</sup>

density of water = 1 000 kg/m<sup>3</sup>

1. An electric kettle rated 1 kW is filled with 5.0 kg of water of known SHC at 20 °C and a current of 4 A flows for 10 minutes through the filament of the kettle. Calculate
  - (i) the operating voltage of the kettle,
  - (ii) the final temperature of water, stating any assumptions made.
2. 2 kg of hot water at 98 °C is quickly transferred into some cold water at 20°C. The final resulting temperature of the mixture is 51.2 °C. Stating any assumptions made, calculate the mass of the cold water.
3. An electric immersion heater works on the mains power supply of 240 V. It takes 20 minutes for the heater to raise

the temperature of 10 kg of water from 20 °C to 60 °C. Show that the current through the heater is about 6 A.

### Answers to remedial activities/questions

1. (i) 250 V (ii) 48.6 °C
2. 3 kg
3. Mark student's work

### Extended activities

This includes more activities more questions to bring out the understanding of the concepts in questions.

In addition, let them attempt the following questions

1. 5 kg of steam at 100°C is condensed fully till it becomes ice at 0°C. Calculate the quantity of heat given out in this process.
2. It takes 3 minutes for an electrical heater to raise the temperature of 1 kg of ice at -10°C to its melting point and another 50 minutes to raise the temperature of water to its boiling point, both under standard pressure. Calculate the ratio of the S.H.C's of water and ice. State any assumption you have made.
3. 450 kg of ice at 0°C is converted into water at 0°C under standard pressure. Calculate
  - (i) the quantity of heat energy required for the process.
  - (ii) the change in volume which occurs during this process.
4. An electric heater takes 36 minutes to completely melt 1 kg of ice at 0°C. Calculate the time it would take to completely convert 1 kg of water into steam at 100°C.



### Answers to extended activities/questions

- 15.08 MJ
- 5 : 3, assuming the power of the heater remains the same.
- (i) 151.2 MJ  
(ii) volume decreases by  $0.05 \text{ m}^3$
- 242 minutes

### Answers to exercise and unit test

#### Exercise 5.1

(Learner's book page 122)

- Heat is a form of energy while temperature is the degree of hotness or coldness of a substance.
- Conduction; transfer of heat from one substance to another there are in direct contact. E.g a spoon inside hot water become hot

Convention; Heat is transferred convection currents in liquids.

Radiation; Heat transfer by emission or transimission of energy in the form of a wave or particales.

- Conductivity of the metal  
Thickness of the material  
Area of the material  
Temperature difference across the material
- Mark according to the experiement the learner has described
- Refer to mechanism of conduction of heat in learners book page 111.
- Refer to activity 5.9 in learners book page 116.
- Refer to learners book page 119.

### Exercise 5.2

(Learner's book page 130)

- Coefficient of linear expansion is the fractional increase in length per unit rise in temperature.
- 26 m
- $0.013889/\text{k}$
- $1.075 \text{ cm}^3$ ,  $241.075 \text{ cm}^3$
- $0.4454 \text{ cm}^3$ ,  $96.4454 \text{ cm}^2$
- $200.166 \text{ cm}^3$

### Exercise 5.3

(Learner's book page 138)

- When solids are heated the molecules vibrate with larger amplitude about a fixed position. This makes them to collide with each other with larger forces which pushes them far a part. The distance between the materials increases and so the solid expands.
- (a) During hot or cold weather the change in length may take place freely without damaging the structure.  
(b) The coops changes slightly when hot or cold water passes through allowing necessary movement of the pipes to take place.
- Making steel bridge  
Construction of railways tracks  
Construction of steam pipes  
Manufacture of glass items
- Length, volume, thickness and area.

### Exercise 5.4

(Learner's book page 141)

- FALSE
- $26.7 \text{ J/K}$
- 13 J

### Exercise 5.5

(Learner's book page 143)

1. 35 °C
2. Heat capacity is the heat energy required to raise the temperature of a substance by 1K while specific heat capacity is the heat energy required to change the temperature of a substance of mass 1kg by 1Kelvin
3. 11.1°C

### Exercise 5.6

(Learner's book pages 151-152)

1. **(a)** Heat capacity is the heat energy required to raise the temperature of a substance by 1K  
**(b)** Specific heat capacity is the heat energy required to change the temperature of a substance of mass 1kg by 1kelvin.
2. **(a)** 26 000 J  
**(b)** 391 000 J
3. Refer to learners book activity 5.26 page 146-147.
4. Its the quantity of heat energy required to change the temperature of 1 kg of water by 1 k. For discussion refer to learners book.
5. 3.27 s
6. 25.9 °C
7. 10.7 kg
8. 630 Jkg<sup>-1</sup>K<sup>-1</sup>
9. Refer to learners book activity 5.27 page 149-150.
10. 63.7°C
11. 4 000 JKg<sup>-1</sup>K<sup>-2</sup>

### Exercise 5.7

(Learner's book page 160-161)

1. Melting is the change of state from solid to liquid of a substance.  
Boiling is the change of state from liquid to vapour.  
Melting point is the fixed temperature at which solid changes to its liquid state.  
Boiling point is the fixed temperature at which a liquid changes state to vapour.
2. Refer to graph in fig. 5.42 learners book page 159.
3. **(a) (i)** Latent heat of fusion of a substance is the quantity of heat energy required to change the substance from the solid to the liquid state without any change in temperature.  
**(ii)** Latent heat of vaporization of a substance is the quantity of heat energy required to change 1kg of a substance from liquid state to vapour state without change in temperature  
**(b)** Because as much as there is no change in temperature heat is being supplied.
4. **(a)** The quantity of heat energy required to change 1kg of a substance from the solid state to liquid state.  
**(b)** Refer to learners book activity 5.29 page 155-156.
5. 8.40x 10<sup>5</sup> J
6. **(a)** 882 000  
**(b)** 882 s; There was no heat loss

7. (a) The quantity of heat energy required to change the substance from liquid to vapour state without any change in temperature.
- (b) Refer to activity 5.30 in learners book page 157-158.

8. 0.398 Kg  
9. 403.5 s

### Unit test 5

(Learner's book page 163-166)

1. D  
2. B  
3. B  
4. C  
5. D

6. **Conduction** – Transfer of vibrational energy from particle to particle

**Evaporation** – Escaping of particles from the surface of a liquid

**Radiation** – electromagnetic waves

**Convection** – Movement of particles due to changes in density.

7. In the correct order ;
- (a) Melt  
(b) vapourise,  
(b) temperatures, ones
8. (a) Quantity of heat energy required to change the temperature substance by 1K.  
(b) Quantity of heat energy of heat required to change the temperature of 1Kg of the substance by 1K.
9. 133.3 J kg<sup>-1</sup>K<sup>-1</sup>

10. (a) 26 000 J (b) 391 000 J  
11. – Water is cheap and readily available  
– It has a high heat capacity  
12. 33 600 J  
13. 8.67 °C  
14. 1 771.4 J/kg<sup>-1</sup>  
15. 1 515 400 J

16. (a) Though both seats may receive same amount of heat a metal surface is a better absorber and emmitter of heat.

(b) Black is a good absorber of heat

(c) Wood is a poor conductor of heat.

17. (a) The dull black surface is to maximize absorbtion of heat while the shinny alluminium foil is to reflect back the heat that may be lost.

(b) Prevent the bounced back rays.

18. 382.5 J/Kg<sup>-1</sup>

19. Total heat = MCAθ + ML + MCAθ  
= (1 × 25 × 4 200) + (1 × 33 400) + 1 × 5 × 2 100  
= 10 500 + 33 400 + 10 500

Total heat = 449 500 J

but

$$\text{Power} = \frac{\text{energy}}{\text{time}}$$

$$1\text{hr} = 3\,600\text{ s}$$

$$\text{Power} = \frac{449\,500}{9\,000}$$

$$2.5\text{hr} = 2.5 \times 3\,600$$

$$2.5\text{hr} = 9\,000\text{ sec}$$

$$\text{Power} = \frac{50\text{ J}}{\text{s}}$$

20. 22 400 JKg<sup>-1</sup>

21. (a) The energy supplied at °C is to increase of give the atoms in ice enough kinetic energy to break/ weaken the intermolecu forces between ice particles.

(b) 45 000 J/kg

**Key Unit Competence**

By the end of this unit, the learners should be able to describe the internal energy of a system by applying laws of thermodynamics.

**Prerequisites to this unit**

For the learners to be able to gain the skills, attitudes and values that will help them in this unit with ease, they need to have acquired the following:

- Knowledge of **heat and work**. These concepts were introduced to learners in S1 and S2 in the topic on work, power and energy and heat. Using question and answer method, the teacher should establish that the learners remember these concepts. Also finding the work done by an object and quantity of heat
- Skills on interpreting heat loss and gain when work is done.

**Cross-cutting issues to be addressed**

The specific cross cutting issues to be addressed in this unit are:

- Include education. All learners are involved in the activities to be performed.
- Environment & sustainability: Heating is some activities using sources of energy which are environment friendly are addressed in the unit. The effect of refrigerators to global warming had to be noted by the teacher as the insulating foam in the innard is made

of a gas that is 1000 times worse than carbon dioxide.

**Generic competences**

The specific generic competences to be addressed in this unit are

- **Cooperation**, interpersonal management and life skills through provision of group work. This will be generated as the teacher involves the learners more in group work.
- **Communication** through provision of discussion based activities. The teacher should encourage all the learners to actively participate in their groups.
- **Critical thinking** and problem solving through involving the learners in problem solving and analyzing concepts of heat being added and removed from a system and what happens to the internal energy of the system.

**Vocabulary/ keywords**

In the course of learning the concepts in this unit, the learners will discover the meaning of the following new words:

- Thermodynamics
- System
- Open system
- Closed system
- Isolated system

Guide the learners to understand the meaning of these words. Construct and

speak out mathematical statements involving vocabularies in order to master their meaning and usage.

### Guidance on the problem statement

To make the learners get prepared and give attention to the unit, the teacher should organize learner to do the following introductory activity in groups, remember it's their first time to learn about thermodynamics. Help them quickly transfer knowledge from heat and work and that even if it's their first time, they can still understand it since it is a practical unit which they themselves experience at home.

### Teaching Aids

- Beaker
- Tripod stand
- Thermometer
- Bunsen burner
- Wire gauze
- Water

### Unit focus activity

- Divide the students into small groups of 4-5 students.
- Guide them to do the Unit Focus Activity Part 1 in the students' book and part 2 as outlined in the student's book on page 168 and 169.
- Learners to define entropy and state how entropy changes in water during heating and cooling.
- Learners to discuss the first and second laws of thermodynamics in their groups.
- Then they explain how the two laws govern the changes in thermal energy of the water during heating and cooling.

- Let them explain how the principle of heat exchange is demonstrated during the cooling of water.
- Ask one student from each group to discuss briefly to the whole class their findings to the class.

### Synthesis

- Let the learners hold a discussion in their groups as they attempt to respond to the questions asked in the activity.
- It is most likely that most learners will come up with different explanations and answers which are incorrect. Encourage them especially the slow learners that the correct answers will be obtained in the process of learning the unit so that by the end of it, they can be able to respond correctly to all questions asked in the unit focus activity.

### Attention to special needs

- Involve all learners including those with special needs during learning activities.
- For the slow learners, organize remedial lessons to guide them through the activities once again and more slowly to help them understand the concepts easily.

### List of lessons

Lesson No.	Lesson Title	No. of periods
1.	Introduction to thermodynamic	1
2.	Internal energy of a system	1
3.	First law of thermodynamics	1
4.	Second law of thermodynamics	1
5.	Heat exchange	1

6.	Change of state and kinetic theory	2
7.	Applications of the principle of thermodynamics (refrigerator) functioning	2
	TOTAL	9

### Note

Remember a period was used on the problem statement activity

### Lesson Development

#### Lesson 1: Introduction to thermodynamic

#### Learning objective

By the end of this section, the learners should be able to define thermodynamic as applied to heat transfer.

#### Teaching Aids

- Water in a beaker
- Thermometer
- Bunsen burner
- Solid ice

#### Preparation to the lesson

Before the lesson, prepare a set of the materials mentioned above for each of the groups.

#### Learning Activities

##### Teaching guidelines for Activity 6.1

- Organize the learners into convenient groups
- Learners to do activity 6.1 as outlined in the student's book page 169. This activity is meant to make the learners understand thermodynamics as a unit in physics.
- Ask them to explain from their previous encounter in unit 5 how

heat travels from one end to another in different states of matter.

- Ask them if particles move from one point to another during heat transfer and define dynamics as applied to heat transfer.
- Ask them to measure the temperature of water in the beaker and heat the water in the beaker until it boils. Then measure the temperature again. Let them compare the readings and tell what they observe.
- Ask them to dip solid ice into the boiled water and measure the temperature of the mixture after all the ice has melted.
- Ask them to explain the laws of thermodynamics in a class discussion.

#### Synthesis

Use a class discussion to help learners consolidate the facts in order to clearly understand;

- The definition of thermodynamics, system, the types of systems and internal energy as discussed in the student book page 170.

#### Answers to activity 6.1

1. Heat travels in three different ways in three different states that is conduction in solids, convection in fluids (liquids and gases) and radiation in a vacuum.
2. It depends on which form of heat transfer. For example in conduction, there is no movement of particle from one place to another, while in convection, hot particles which are less dense move upwards and they are replaced by cold particles which are more dense hence movement of particles.



3. Dynamics is the study of why things move the way they do.
  4. The temperature of the liquid increases.
  5. Ice melts and the temperature of the mixture reduces.
  6. The first law is another way of stating the law of conservation of energy which states that the change in the **internal energy** ( $\Delta U$ ) of a system is equal to the sum of the **heat** ( $q$ ) that flows across its boundaries and the **work** ( $w$ ) done on the system by the surroundings. The second law can be stated as Heat flows spontaneously from a hotter object to a colder one, but not in the opposite direction; the reverse cannot happen without the addition of energy or the spontaneous change for an irreversible process in an isolated system always proceeds in the direction of increasing entropy. In other words, the entropy of any isolated system always increases.
- Guide them to do activity 6.2 given in the student's book on demonstrating and explaining internal energy of a system as outlined in the student's book page 170-171.
  - Ask them to drop three marbles in the transparent container and shake it. Let them observe what happens to the marbles positions.
  - Ask them to explain internal energy in relation to thermodynamics taking the container as a system and the marbles as internal energy.
  - Let them research from the internet and reference books on internal energy.
  - Learners to share their findings to the rest of the class.

## Lesson 2: First law of thermodynamic

### Learning objective

By the end of this lesson, the learner should be able to describe the internal energy of a system.

### Teaching Aids

- Marbles of two different colours.
- Transparent container
- Reference books
- Internet

### Learning activity

#### Teaching guidelines for Activity 6.2

- Organize the learners into pairs.

### Synthesis

Through a class discussion, help all the learners to fully appreciate that:

- The internal energy of a system is identified with the random, disordered motion of molecules. The total(internal) energy in a system includes
  - i) Translational kinetic energy
  - ii) Vibrational and rotational kinetic energy
  - iii) Potential energy from intermolecular forces.

### Answers to activity 6.2

Each colored marble will be seen to change its original position. The marbles don't remain in their original position.

The internal energy of a system is identified with the random, disordered motion of

molecules. The total internal energy in a system is the translational kinetic energy, vibrational and rotational kinetic energy and potential energy from intermolecular forces.

### Lesson 3: First law of thermodynamics

#### Learning objective

The learner should be able to explain the first law of thermodynamic.

#### Teaching Aids

- Beaker
- Water
- Bunsen burner
- Thermometer

#### Preparation for the activity

Before the lesson, prepare a set of the materials mentioned above for each of the groups that will be formed.

#### Learning activity

##### Teaching guidelines for Activity 6.3

- Organize the learners into groups of five students.
- Guide the learners to do activity 6.3 given in the student's book page 171 on demonstrating the first law of thermodynamics as outlined in the student book page 171-172.
- From the activity, let them explain the first law of thermodynamics.
- Ask them to write down their deduction, complete their finding with the teacher and write down the notes in their books.

#### Synthesis

Use a class discussion to help learners consolidate the facts in order to clearly;

- The law of conservation of energy is summarised in the first law of thermodynamics. It states that the change in the internal energy ( $\Delta U$ ) of a system is equal to the sum of the heat ( $Q$ ) that flows across its boundaries and the work ( $W$ ) done on the system by the surroundings.
- The main things to note about the first law are
  - i) The absorption of heat by the system tends to raise the energy of the system and vice versa. Therefore, in the equation, we take heat ( $Q$ ) to be positive if it is supplied to the system and negative if heat is dissipated (removed) from the system.
  - ii) Also that the performance of work by the system requires expenditure of energy hence lowers the energy of the system, and vice versa. Therefore, in the equation, we take work done as positive if it is done on to the system and negative if it is done by the system.
- Guide them in a discussion on example 6.1, 6.2 and 6.3 given in the student's book page 172-173.

#### Assessment

- Ask the learners to do exercise 6.1 on page 174

#### Answers to activity 6.3

2. According to the first law of thermodynamics, the increase in internal energy of a system equals the work done on the system plus the heat transferred to the system. Doing work on a system is a way of adding energy to the system, as a

result its temperature can be increased by adding heat to the system or doing work to the system or both. It is another way of stating the law of conservation of energy.

#### Lesson 4: Second Law of Thermodynamics

##### Learning objective

The learner should be able to state and explain the second law of thermodynamics.

##### Teaching Aids

- 20 red marbles
- 20 green marbles
- Tray
- Reference books
- Internet

##### Learning Activities

###### Teaching guidelines for Activity 6.4

- Organize the learners into convenient groups of five
- Ask them to do activity 6.4 as outlined in the student's book on page 174-175 that is to define and explain the term entropy.
- Ask them to do research on entropy and discuss their findings in a class discussion.

###### Synthesis

- Through a class discussion, help the learners to fully appreciate that the concept of entropy that nature tends to move from order to disorder in isolated systems and that the state of confusion or disorganization always increases to a state that can't make them be returned to their original

state. Entropy is the measure of a systems thermal energy per unit temperature that is not available to do useful work. In other words it's the measure of the molecular disorder or randomness of a system.

##### Answers to activity 6.4

3. They are in a disorganized state. Mixed up.
4. When the internal energy of a body is increased by heating, the translational kinetic energy, vibrational and rotational kinetic energy are all increased which increases their movement within the body. Hence the change in most particles from their original positions and thus getting disorderly.
5. Entropy is the measure of the molecular disorder, or randomness of a system or the measure of the systems thermal energy per unit temperature that is not available to do useful work.

##### Teaching aids

- Beaker
- Ice burner
- Water
- Thermometer

##### Learning activity

###### Teaching guidelines for Activity 6.5

- Organize the learners into pairs.
- Guide them to do activity 6.5 given in the student book that is to demonstrating the second law of thermodynamics as outlined in the student book page 175.

- The learners to discuss with their partners whether the two processes that took place in step 3 of the activity would be reversed, similarly if after taking place, the beaker is heated again.

#### Synthesis

Use a class discussion to help consolidate the facts that:

- When a block of ice is placed on a hot stove it surely melts, and at the same time stove cools. Such a process is called irreversible because after taking place, heating the stove again will not make the melted water to freeze back to ice again.
- The increase in thermal energy of a cool object equals the decrease in thermal energy of the warm object.
- Summarize the activities by stating for the learners the second law of thermodynamics as outlined in the student book.

#### Assessment

- Ask the learners to do Exercise 6.2 on learners book page 176.

#### Answers to activity 6.5

2. The temperature can be any figure depending on the time taken to heat it. Let the temperature be 20.
3. When ice is dropped into the heated water, the temperature as the ice melts until all the ice melts.
4. They can't be reversed.

### Lesson 5: Heat exchange

#### Learning objective

The learner should be able to describe heat exchange, explain the work done on

a system when heat energy increases or reduces and determine the quantity of heat using the method of mixtures.

#### Teaching Aids

- Water
- Beakers
- Thermometers
- tripod stand
- Bunsen burner
- wire gauze
- stirrer

#### Preparation to the lesson

Before the lesson, make sure that the set of the materials mentioned above for each of the activities are ready.

#### Introduction to the lesson

Introduce the lesson by using question and answer method to guide the learners to review the definition of heat, heat transfer and why heat transfers.

#### Learning Activities

##### Activity 6.6

- Organize the learners into convenient groups.
- Then they do Activity 6.6 as outlined in the student book on demonstrating heat exchange using cold and hot water on page 177.
- Ask them to state the direction of heat flow during the mixing of hot and cold substances.

#### Synthesis

Use a class discussion to help the learners to consolidate the facts in order to clearly understand;

- Heat transfer is the exchange of thermal energy between physical systems. It moves from one system to another because of temperature difference in the given systems. The direction of heat transfer is from the region of high temperature to that of lower temperature as discussed in the student book page 177-178.
- Guide the learners through example 6.4 in the learner's book pages 178-179

#### Teaching guidelines for Answers to activity 6.6

- In step 1, the temperature beaker B is 15.
- In step 3, the temperature in beaker A is higher and it is 25
- In step 5, the final mixture has a temperature of 20.
- In step 6, the final temperature of the mixture is more than the initial temperature in beaker B. the temperature in beaker B has increased. Because of the transfer of heat from a hotter liquid to a colder one (in B), the temperature of B increases.
- In step 7, the direction of heat is A to B.
- In step 8, heat always moves from where it is much to where it is less.

#### Teaching Aids

- Water
- Tripod stand
- Stirrer and beam balance
- Beakers
- Bunsen burner
- Thermometer

- Wire gauze

#### Learning activity

##### Teaching guidelines for Activity 6.7

- In their convenient groups ask them to do activity 6.7 on showing the quantity of heat using the principle of heat exchange as outlined in the student book on page 178.

#### Synthesis

Having done the activity, guide the learners through a class discussion to do example 6.4 on page 178-179.

### Lesson 6: Change of state and kinetic theory of matter

#### Learning objective

The learner should be able to state the kinetic theory of matter, demonstrate change of state as a result of internal energy, and describe the three states of matter using the kinetic theory of matter.

#### Teaching aids

- Reference books
- internet

#### Learning activity

##### Teaching guidelines for Activity 6.8

- Organise the learners into convenient groups and guide them to do activity 6.8 given in the student's book on kinetic theory and the three different states of matter as outlined in the student's book page 179-180.
- They to identify the three states of matter. Using figure 6.2, let them

identify the different changes of state A to F.

- Ask a few students to come and present their findings to the rest of the class in a class discussion.

### Synthesis

Having done the activity, guide the learners through a class discussion to understand that:

- The three states of matter are solid, liquid, and gas. The processes taking place in the diagram are A-sublimation, B-Melting, C-boiling/evaporation, D- freezing/solidifying, E-condensing and F- deposition.
- During the changing of state, the temperature of the gas/liquid/solid is constant.
- The changes of state can be explained by using the kinetic theory of matter as outlined in the students book .
- The kinetic theory of matter is theory that tries to explain the properties and behaviors of the three states of matter. It makes the following 3 assumptions as given in the student's book on pages 180-182.

### Answers to activity 6.8

- In step 1, solid, liquid and gas.
- In step 2, A-sublimation, B-melting, C-boiling, D-freezing/solidification, E-condensation, F-deposition
- In step 3, matter (solid, liquid, and gas) is made up of tiny particles called atoms, or atoms that are joined to form molecules. The second assumption describes the separation of the particles. In a gas, the separation between particles is very large compared to their size, such that

there are no attractive or repulsive forces between the molecules. In a liquid, the particles are still far apart, but now they are close enough that attractive forces confine the material to the shape of its container.

In a solid, the particles are so close that the forces of attraction confine the material to a specific shape. The third assumption is that each particle in matter is in constant motion.

## Lesson 7: Applications of the principle of thermodynamics

### Refrigerator functioning

#### Learning objective

The learner should be able to explain basic working principle of a refrigerator.

#### Teaching Aids

- Tomato
- Ether

#### Learning Activities

##### Teaching guidelines for Activity 6.9

- Organize the learners into convenient groups
- Guide them to do activity 6.9 given in the student's book on the basic working principle of a refrigerator as outlined in the students' book page 183.
- Ask them to discuss why there is a change in the temperature of the apple after ether was poured on it.
- Ask them to share their findings to the rest of the class

#### Synthesis

Having done the activity, guide the learners through a class discussion to



understand that:

- The temperatures are different and that before ether was poured on the Tomato, the temperatures were high but when ether is poured on, the temperatures of the Tomato reduces. The reason is that when a volatile liquid is poured onto a surface, it quickly evaporates absorbing the heat from that surface and as a result, the surface is cooled. Let them know that this is the same way a refrigerator works to keep food stuffs or drinks cold or makes them cold.
- Explain the working of the refrigerator as outlined in the student's book on pages 184-185.

#### Assessment.

- Ask the learners to do exercise 6.3 in learners book page 182-183.

#### Answers to activity 6.9

- In step 1, the temperature is normal.
- In step 2, the temperature reduces than normal
- In step 3, the temperature in step 2 is less than the temperature in step 1. The temperature in step 1 is higher.
- In step 4, the temperature in step 3 is less because the heat in the apple has been taken away by ether thus reducing the temperature.

### Lesson 8: Melting and solidification

#### Learning objective

By the end of this section, learners should be able to differentiate and explain melting from solidification.

Safety; learners must be warned to take care while using the Bunsen burner to avoid accident. In fact the teacher or the lab attendant should help in lighting it.

#### Teaching Aids

- Thermometer
- glass beaker
- crushed ice
- tripod stand
- Bunsen burner
- wire gauze
- Stop clock watch or clock.

#### Learning Activities

##### Teaching guidelines for Activity 6.10

- Organize learners into convenient groups of three or five to do activity 6.10 as outlined in the student book page 185. This activity is meant to help the learners understand the steps of a melting substance.
- Learners to plot a graph of temperature against time for the results obtained in the table 6.1. Let them use their knowledge of matter to explain the shape of the graph.

#### Synthesis

Having done the activity, guide the learners through a class discussion to understand that:

- Melting is the change of state from solid to liquid at the melting point of the substance. Explain the parts of the graph as outlined in the student's book on page 185-186.
- Solidification is the change of state from a liquid to a solid. Explain the cooling curve for water as outlined in the student's book on page 186.
- The factors that affect melting/ freezing point of a substance as pressure and impurities as outlined in the student book.

### Answer to activity 6.10 page 185

- In step 2, the temperature is -10
- In step 5, the tale of results is as below

Time (s)	0	30	60	90	120
Temp (°C)	-10	0	0	50	100

In step 7, use the graph in the student book on page 186.

- In step 8, the temperature of ice rises steadily from -10 °C to 0 °C. During this time, along AB, the ice remains as solid. At 0 °C, along the line BC, the temperature remains constant for a period of time. During this period, the ice is observed to be melting. During the melting process, solid and liquid exist in equilibrium. After all the ice has melted, the temperature of water starts rising again as seen along the line CD of the graph.

### Factors affecting melting point

#### Teaching aids

- Ice block
- Soft pad
- 2 Cement blocks
- 2 equal weights
- Wire

#### Learning activity

##### Teaching guidelines for Activity 6.11

- Organize the learners into convenient groups
- Ask them to do activity 6.11 given in the student's book on showing the effect of pressure on the melting point of ice as outlined in the students' book page 188.

### Synthesis

Having done the activity, guide the learners through a class discussion to understand that;

- If a substance expands on solidifying then application of pressure on it will lower its melting point. On the other hand, substances that contract in volume on solidifying, their melting points raises.
- The phenomenon where ice melts when pressure is increased and solidifies again when the pressure is reduced is called regelation as outlined in the student book on page 188.

### Assessment

- Ask the learners to do exercise 6.4

### Answer to activity 6.11

When the wire with weights is put on the ice block, the ice melts and the wire enters into the water from the melted ice. As the wire is descending down, it is seen that the water at the top becoming ice again until the wire falls through the piece of ice.

### Answers to unit focus activity

#### Part 1.

The initial temperature can be any temperature say 15, when water is heated for two minutes, its temperature rises to 19. When it's allowed to cool for one minute, the temperature becomes 17.

#### Part 2.

1. (a) Entropy is the measure of the molecular disorder, or randomness of a system.

- (b) (i) during heating the entropy of a system increases because as particles are given more kinetic energy because of the increase in temperature, they move about so fast and in a disorganized manner.
- (ii) During cooling, heat will transfer and get distributed over two bodies that is water and the vessel it is in, the environment and therefore leading to a disorganized state. The entropy of the water is going to decrease but the one of the vessel plus the environment will increase.
2. (a) The first law of thermodynamics states that the change in the internal energy of a system is equal to the sum of the heat that flows across its boundaries and the work done on the system by the surroundings. The second law of thermodynamics states that the spontaneous change for an irreversible process in an isolated system always proceeds in the direction of increasing entropy.
- (b) (i) During heating, the heat applied will be equal to the increase in internal energy of the body if there is no work done on that same body from the first law of thermodynamics. According to the second law of thermodynamics, there is increase in the general entropy of the system when it is heated.
- (ii) During cooling, it's the hot object that loses heat to the surrounding as stated in the second law of thermodynamics that heat flows from a hotter object to a colder one. And from the first law of thermodynamics, the loss in heat by the hot object is directly equal to the gain in heat by the cooler surrounding.
3. The principle of heat exchange shows that the direction of heat transfer is always from the hot to cold because of a difference in temperature. When hot water is left in a container for some time, its temperature will reduce as heat goes into the surrounding ( into the container and the environment). As heat is lost, its temperature reduces thus cooling.

### Summary of Unit.

Summarize the unit by:

- Asking different learners to take the class through the different concepts highlighted in the unit summary given in the learner's book page 190-191. Ask the class probing questions to help them recall the concepts correctly.

### Additional information to the teacher.

- Heat can be converted to work. It may not violate the first law of thermodynamics but it is forbidden by the second law of thermodynamics. However it is because of the second law that we can build devices that convert heat to work. A devices that convert heat into work is an heat engine. A car's engine is an example of

a heat engine. A car's engine converts chemical energy in gasoline into heat. The engine then changes some of the heat energy into work by rotating the car's wheel.

- Air conditioners; an air conditioner is a type of heat mover which operates just like the refrigerator, except that the warm air from the room is forced to pass over the tubes containing a coolant. The warm air is cooled and is forced back into the room. The thermal energy that is absorbed by the coolant is transferred to the air outdoors. Air conditioners and refrigerators are heat engines working in reverse that is to say they use mechanical energy supplied by the compressor motor to move thermal energy from cooler to warmer areas.
- Zeroth law of thermodynamics – If two thermodynamic systems are each in thermal equilibrium with a third, then they are in thermal equilibrium with each other.
- Third law of thermodynamics – As temperature approaches absolute zero, the entropy of a system approaches a constant minimum.

#### **Remedial activity for slow learners.**

1. In a certain process, 675 J of heat is absorbed by a system while 290 J of work is work done on the system. What is the change in internal energy for the process?
2. In a certain process, 12 000 J of heat is added to a system while the system does work equivalent to 18 000 J by expanding against the surrounding atmosphere. What is the change in internal energy for the system?
3. In a certain process, 500 J of work is done on the system which gives off 150 J of heat. What is the change of internal energy for the process?
4. Describe the thermal energy of an object when the object's temperature changes.

#### **Answers to remedial activities/ questions for slow learners.**

1. 300 J
2. 280 J
3. 32 J
4. When the temperature of an object changes, since thermal energy is the total of the kinetic and potential energies of particles in a body, it will change as the temperature determines the average kinetic energy of the particles

#### **Remedial activities for gifted learners**

1. Predict whether energy will ever spontaneously transfer from a cold sauce pan of water to a hot stove.
2. Explain how the thermal energy of an isolated system changes with time if the mechanical energy of that system is constant.
3. Think critically and explain whether or not the following statement is true: for any two objects, the one with the higher temperature always has more thermal energy.
4. Explain when heat flows between two objects, does the temperature increase of one object always equals the temperature decrease of another object?
5. Explain how the temperature of the juice in the bottle will change if the bottle is shaken vigorously.

### Answers to remedial activities for gifted students

1. According to the second law of thermodynamics, energy can only be transferred from a hot region (higher concentration) to cold regions (lower concentrations) but it is not possible for it to move from lower concentrations to higher concentrations just spontaneously.
2. Thermal energy of an isolated system changes with time if the mechanical energy of the system is constant according to the first law of thermodynamics, which states that the thermal energy of an isolated system can still change as long as the energy of the system does not change
3. It is not true that the one with the highest temperature has the most thermal energy. This is because a big object (big mass) may have less temperature but with more particles so its average kinetic energy of the particles is less but its thermal energy is high because it talks about the total kinetic energy. In other words a small object (small mass) needs less thermal energy to heat up.
4. The temperature increase will not be equal to temperature decrease of another because the temperature increase or decrease depends on the specific heat capacity of objects and their masses. When the two are different so is the temperature increase or decrease going to be different.
5. When a bottle of juice is shaken vigorously, the temperature of the juice will change because of the different energy transformations that take place. Shaking will most likely

bring about particles moving faster thus increasing the kinetic energy. Since temperature is the average kinetic energy of the particles, the temperature of juice will become warmer.

### End of unit assessment

- Ask the learners to do the unit test 6 given in the student book on page 191-193.

### Answers to exercises.

#### Answers to exercise 6.1 on page 174

1. B
2. B
3. B
4. Internal energy
5. decrease, increase

#### Answers to exercise 6.2 on page 176

1. B
2. C
3. D
4. C
5. A

#### Answers to exercise 6.3 on page 182-183

- |      |       |
|------|-------|
| 1. C | 6. D  |
| 2. B | 7. C  |
| 3. C | 8. B  |
| 4. B | 9. C  |
| 5. B | 10. B |

#### Answers to exercises 6.4 on page 189-190

1. D
2. A
3. A

#### 4. Functions of the parts of the refrigerator

- (a) Compressor- the compressor is located at the back of the refrigerator and in the bottom area. The compressor sucks the refrigerant from the evaporator and discharges it at high pressure and temperature. Its main function is to transform a low temperature vapor into a high temperature vapor, to increase pressure. The compressor is driven by the electric motor and it is the major power consuming device of the refrigerator.
- (b) Condensing coil- the heat in the refrigerant is absorbed by the condensing coil. It changes the gas to liquid form. Its main purpose is to liquefy the refrigerant gas sucked by the compressor from the evaporator
- (c) Evaporator - it turns any liquid material into gas. In this process, heat is absorbed. The evaporator transfers heat from the refrigerated space into a heat pump through a liquid refrigerant, which boils in the evaporator at a low pressure. In achieving heat transfer, the liquid refrigerant should be lower than the goods being cooled. After the transfer, liquid refrigerant is drawn by the compressor from the evaporator through a suction line. Liquid refrigerant will be in vapor form upon leaving the evaporator coil
- (d) A refrigerator thermostat/ cold control is found inside the refrigerator and has a knob which allows users to adjust the

temperature setting. When the user sets the desired temperature, the thermostat maintains the temperature by controlling the flow of electric current to the compressor. When the air inside refrigerator is at the required temperature, it stops the flow of electricity and if it senses too much heat, it allows electricity to flow to the compressor.

- 5. At the end of the refrigerator is the condensing coils in which there is latent heat of fission given out as the gas is changed into the liquid. If the refrigerator is near the wall, this heat destroys the wall by burning it.
- 6. (a) Melting is the change of state from solid to liquid at the melting point of the substance.  
(b) Solidification is the change of state from a liquid to a solid.
- 7. Refer to discussion in students book page 186. Explain the cooling curve for ice
- 8. (a) Condensation  
(b) Internal energy  
(c) increases  
(d) Heat  
(e) Entropy

#### Unit test 6 on page 191-193

- 1. B
- 2. A
- 3. B
- 4. B
- 5. A
- 6. D
- 7. B



8. D
9. D
10. The law states that the change in the internal energy ( $\Delta U$ ) of a system is equal to the sum of the heat ( $q$ ) that flows across its boundaries and the work ( $w$ ) done on the system by the surroundings.
11. When kinetic energy of a gas is reduced the particles vibration decreases and thus the spaces between the molecules is reduced and this causes cooling down of the gas thus turning into a liquid through a process of condensation. Further cooling causes the liquid to turn into a solid through freezing.
12. (i) Through reducing pressure by pulling out the piston.
- (ii) By increasing the temperature of the gas by heating the metal can.
13. – ice melting  
– salt or sugar dissolving  
– making popcorn.
14. Thermol equilibrium is the state of a system in which heat flow is balanced with surroundings.
15. (a) Open system is one in which there is exchange of matter with its environment while a closed system is one in which it is isolated from their environment.
- (b) Reversible process is one which can be retracted without producing any effect on the environment e.g melting ice while irreversable process is one which can not be retracted back in the opposite order r.g burning of wood.
16. 350 J
17. 1000 J

**Key Unit Competence**

By the end of this unit, the learners should be able to apply the principal of electromagnetic induction.

**Prerequisites of this unit**

This unit deals with generation of an electric current using a magnetic field. You should therefore review work done in magnets (S1), simple electric current done in S1 and S2. For electric current emphasize should be on the direction of electric current i.e. conventional direction. For magnets emphasize on how to change magnetic field strength of a permanent or/and temporary magnets. Making and destroying a magnet needs a mention.

**Cross cutting issues to be addressed**

The following gender issues have been addressed.

*Gender*

- In forming working groups encourage groups that have both males and female in case the class is mixed one.
- The language used in describing the participation of students in activities is carefully selected to avoid she, he, chairman, chairlady etc. Use chairperson.

*Peace and value education*

- The teacher is encouraged to form working groups that do not have permanent members. Students should

work without any conflict all the time.

- In class discussion students are encouraged to respect each other's opinion no matter how wild the opinion. It is the work of the teacher to harmonize such opinions.

*Inclusive education*

- All students irrespective of their learning abilities and disabilities learn together as in performing activities and class discussion. The use of Flemings' law using fingers is required. The use of other methods is applied to address this disability.

*Standardization culture*

- The use of standard apparatus culture e.g. Galvanometer, magnets, ideal transformers emphasizes the culture of buying and using standard items. Cheap is expensive!
- In drawing of circuit's diagram, care is taken in using standard symbol of electric circuit. These symbols were introduced in S1 and S2.

*Environment and sustainability*

- The unit has dealt with Transformer use oil for cooling. The oil leaks from transformer destroys our environment. The use of air-cooled transformer is suggested which are sustainable and friendly to human beings, animals and plants.

### Generic competences

The specific generic competences to be addressed in this unit include among others the:

- *Critical thinking*: This competence will be achieved when the teacher will involve learners in doing activities especially the unit focus activity and answering questions in the exercises 7.1, 7.2, 7.3, 7.4 and unit test 7 that require the learner to explain, discuss and describe the particular concept.
- *ICT*: This competence will be achieved when the teacher will involve learners in conducting research from Internet on electromagnetic induction.
- *Problem solving*: This competence will be achieved when the teacher involve learners in activities and exercises on electromagnetic induction.

### Vocabulary /Keywords

In the course of learning the concepts in this unit, the learners will discover the meaning of the following new words:

- Electromagnetic induction
- Faraday's law
- Lenz's law
- Root-mean-square
- Peak value
- Angular velocity

Guide the learners to understand and explain these words in sentences relating to Physics concepts.

### Guide on the problem statement

In order to motivate learners and make them eager, attentive and active when learning the concepts in this unit, facilitate

them to do the unit focus activity (Try this) outlined in the student's book page 195-196.

### Teaching aids required

- Microphone
- Chart showing parts of a simple a.c generator

### Teaching guidelines for unit focus

- Organise learners into appropriate groups. Prompt them to see the need of having a group leader and secretary. This will promote leadership skills among the learners.
- Provide them with the microscope and the chart.
- Let them suggest the use of a microphone and tell whether they have ever seen the device in picture on the chart. This will promote critical thinking in learners.
- Ask them to do unit focus activity given in the student's book pages 195-196.
- Allow learners to hold a discussion in their groups as they attempt to respond to all questions asked in the activity. This will promote cooperation, communication skills and leadership skills among other competences in the learners.
- Use their feedback to guide them in such way that leads to the correct responses to the questions asked in the activity. The teacher can use probing questions. By doing that, you will be promoting critical thinking of your learners.

- It is most likely that most learners will come up with different observation, explanation, and description that are inaccurate. At this point, show the learners the importance of accepting different opinions given by different learners whether right or wrong. This help to promote peace and harmony among the learners.
- Use their feedback to trigger their curiosity in order for them to see the need of learn more from the unit.
- Encourage those learners who may have not responded correctly especially the slow learners that the correct answers will be obtained in the process of learning the unit so

that by the end of it, they can be able to respond correctly to all questions asked in the unit focus activity.

#### Attention to special educational needs

- The unit demands a lot of observations in different activities given, for example observation on the galvanometer. Students with eye challenges should be involved in the activities in different ways such as giving them a magnet and told to move it into the coil as the other student observe what happens to the pointer of the galvanometer.
- The use of remedial extended activities to encourage those students with special educational needs.

#### List of lessons

Lesson No.	Lesson title	Number of period
1	demonstration of electromagnetic induction	1
2	Factors affecting the magnitude of emf induced	1
3	Laws of electromagnetic induction	1
4	E.M.F induced in a straight conductor moving in a straight field	1
5	E.M.F induced in a coil rotating in uniform magnetic field	1
6	Alternating current (a.c )generator	1
7	Root-mean-square (r.m.s) value	2
8	Other applications of electromagnetic induction	1
9.	Unit assesment	1
	TOTAL	10

#### Lesson 1: Demonstrating of electromagnetic induction

##### Learning objective

By the end of this lesson, the learner should be able to explain electromagnetic induction

##### Teaching aids

- Source of power
- Copper wire (conductor)
- Bar magnet
- Magnet
- Conducting wire
- Switch
- Galvanometer
- U-shaped magnet

### Introduction to the lesson

In S1, learners learnt about electric circuit. They also learnt about electric components and symbols. Using a simple circuit, introduce the lesson by connecting simple circuits. Use it to ask questions such as why does the bulb light?

Also, through questions and answers method let the learners realize the importance of a visible power source to have the bulbs light. Inform the learners that the bulb can light even if there is no visible source of power.

### Learning activities. Activity

#### Teaching guidelines for activities 7.1, 7.2 and 7.3

- Organise learners into convenient groups depending on the availability of suggested materials. Working in groups will promote cooperation, interpersonal relation among other competences.
- With your guidance, let them do activities 7.1 to 7.3 provided in the student's book pages 196-199.
- These activities demonstrate the generation of electric current. Guide them through the activities by demonstration. Allow them to do the activities on their own.
- Give learners few minutes to discuss their observations and results obtained from the activity. Ensure that all group members are participating in the discussion. This will promote communication skills and critical thinking among themselves.

- Ask the group secretaries to give a brief report to the whole class on their findings. By doing so, leadership skills and communication skills are enhanced in learners.
- Point out any errors or omission in each report given. At this point, let the learner know that it is always crucial to appreciate other student's views whether right or wrong and if they disagree, let them do so constructively. Hence they will be learning how to be tolerant to one another and therefore promoting peace and harmony among themselves.

### Synthesis

Having done the activities, hold a discussion with learners to emphasize the need of relative motion for this generation. This relative motion is such that the wire "cuts" the magnetic field line of force.

Use figures 7.8 and 7.9 to introduce the concept of change in magnetic flux  $\Phi = B.A$ . Fig 7.10 shows when magnetic flux is directly proportional to the number of magnetic field and area of the loop of the coil.

Change in magnetic flux is responsible for generation of electric current. The change can be from high to low or low to high. The only thing that changes in the flow of electric current is the direction.

### Assessment

Ask the students to do exercise 7.1 questions 1, 4 and 5.

### Answers to activities 7.1-7.3

Refer to the discussion given in the student's book after each activity.

### Lesson 2: Factors affecting the magnitude of emf induced

#### Learning objective

The learner should be able to explain factors affecting the magnitude of emf induced

#### Teaching aids

- Insulated copper wire
- Galvanometer
- Bar magnet
- Connecting wire

#### Introduction to the lesson

In this unit, learners have learnt how induced emf is produced. They have carried out activities that demonstrate the production of emf. Using activity 7.4 given in the student's book page 201, let learners suggest factors that affect the magnitude of emf induced. This activity will demonstrate clearly how the speed affects the induced emf. Use this as a foundation to build up the lesson on other factors.

#### Teaching aids

- Insulated copper wire
- Galvanometer
- Bar magnet
- Connecting wire
- Ceramic magnet
- Iron rod

### Learning activities

#### Teaching guidelines for activity 7.4

- By now the learners should be able to organise themselves appropriately into different groups without your help whenever they are asked to do so. This does not mean you don't need to check and reorganise them where necessary. Therefore, organise them into convenient groups depending the availability of suggested learning materials and let them be ready to do activity 7.4. Working in groups will enhance *personal* and *interpersonal management, teamwork* and *cooperation* among learners.
- Prompt them to see the need of having a group leader and a secretary.
- Provide them with the suggested materials in the activity, that is, Insulated copper wire, bar magnet, galvanometer, and connecting wires.
- Lead by the group leader, now ask the learners to do activity 7.4 in the student's book pages 201, that is, to investigate the magnitude of the induced emf. This will promote *leadership skills* in learners.
- Visit different groups to ensure that they are doing the right thing. They should be able to connect the galvanometer to the coil they have made.
- Hold a discussion on their findings. Allow learners to give their observations and explanation to the class and guide them appropriately.



### Synthesis

Learners having done the activity and discussed the findings, let them understand the following facts the magnitude of induced emf is directly proportion to:

- The induced emf is much higher in the presence of a soft iron core
- The number of turns in the coil.
- The strength of magnetic field
- The rate of change of the magnetic flux linked to the coil

### Answers to activity 7.4

- In step 3, the pointer of galvanometer moves quickly when the motion of the magnet is increased.
- In step 4, when the coil is wound on a soft core, the pointer moves faster than without core.
- In step 5, core with more turns result to a faster movement of the pointer than with the few turns.
- In step 6, when permanent magnet is used it results to faster movement of the pointer than when temporarily magnet is used.

## Lesson 3: Laws of electromagnetic induction

### Learning objective

By the end of this lesson, the learner should be able to state the laws of electromagnetic induction

### Teaching aids

- Magnet
- Centre- zero –galvanometer
- Insulated copper wire
- Connecting wires

### Introduction to the lesson

Review what has been covered so far emphasis the results of activity 7.2. Link the results with the lesson of the day.

### Learning activities

#### Teaching guidelines for activity 7.5

- Maintaining the groups used in activities 7.1-7.4. Working in groups promotes cooperation, personal and interpersonal management among learners.
- Now, ask learners to do activity 7.5 in the student's book page 202, that is, to state the laws of electromagnetic induction. This activity involves the use of hands. Those learners with any disability of hands should be involved by being asked to observe keenly and contribute by giving their observations. By doing so, you have ensured that all learners are involved in the learning activity.
- Guide the learners in determining the factors affecting the size of magnitude of induced e.m.f.
- Let the learners state the Faraday's law their own words. As a conclusion or summary to activity 7.5 state the Faraday law as it should be stated in words and mathematically in the mathematical expression introduce a minus sign. This will promote communication skills in learners.
- Emphasis the statement "change producing". Demonstrate the "change producing" as suggested in the students book using; a coil, bar

magnet and a galvanometer. Use and explain direction of current in straight conductor using Fleming's right hand rule.

### Synthesis

Summarise the two laws of electromagnetic induction both in words and mathematical expressions

Fleming's right hand rule

ThMb	SeCond	First
o	u	i
t	r	e
i	r	l
o	e	d
n	n	
	t	

When stating Faraday's laws in reference to a coil, you should define magnetic flux as a product of magnetic field strength, B and area, A threaded by the field line. The magnetic flux changes when the magnetic is withdrawn from the coil.

### Assessment

Ask the students to attempt questions 2,3,6 of exercise 7.1 pages 206-207 as a takeaway assignment. You should mark and discuss with the learners the assignment before moving to the next lesson.

### Answers to activity 7.5

Refer to the discussion given in the student's book.

## Lesson 4: E.M.F induction in a straight conductor field

### Learning objective

By the end of this lesson, the learner should be able to derive an expression of induced EMF in a straight conductor.

### Teaching aids

- Connecting wires
- Two permanent magnets
- Centre zero galvanometer
- Conductors

### Introduction to the lesson

Let the students set up the magnet and the conductor as shown in the fig. 7.19 in the student's book page 208.

### Learning activities

#### Teaching guidelines for activity 7.6

- Organise your learners into appropriate groups depending the availability of suggested learning materials. Ensure that the groups formed are gender sensitive (in case your class has boys and girls) and of different abilities. Working in groups will enhance teamwork and cooperation among learners.
- With your guidance, ask them to do activity 7.6 given in the student's book page 207-208, that is to determine the magnitude of induced e.m.f in a straight conductor.
- The activity may be enjoyable and amazing to the learners, but let them not lose the main concept of the activity i.e. the movement of the magnet in and out of the coil results to production of emf.
- Let the learners discuss their observation from the activity. This will promote communication skills among your learners,
- Using their discuss with them on the chalkboard how the rate of changed area and magnetic flux are related

mathematically. This will enhance critical thinking, communication, and writing problem solving skills among other competences in learners.

#### Synthesis

Having done activity and held comprehensive discussion, highlight the discussion in the students book page 208-209:

- Discuss with the learners example and 7.3 and 7.4 on page 209 in the student's book.

#### Assessment

Select some question in exercise 7.3 student's book page 213-214 and give as supervised practice.

#### Answers to activity 7.6

Refer to the discussion given in the student's book page 208 - 209.

### Lesson 5: E.M.F induction in a coil rotating in uniform magnet field

#### Learning objective

By the end of this lesson, the learner should be able to derive an expression of induced EMF in a coil rotating in a uniform magnet field.

#### Teaching aids

- A coil
- Centre-zero galvanometer
- Two permanent magnet
- Connecting wires

#### Teaching guidelines for activity 7.7

- Using the same groups used in activity 7.5, ask learner to do activity 7.9 given in the student's book page 210.

- Guide the learners through the activity to realize the difference in the deflection of the pointer of the galvanometer when the area of the loop of wire is changed.
- Let learners suggest the reasons for the difference and allow them to come up with the relationship between induced emf and area of conducted used.
- Hold a discussion with learners on their findings.

#### Synthesis

Discuss with the learners how the question of induced emf can be derived. Use the chalkboard to do this.

Ensure the learners have understood the equation  $\varepsilon = -BA \omega \sin \omega t$  and  $\varepsilon = \varepsilon_0 \sin \omega t$  Discuss the examples 7.5 given in the student's book page 212 on the chalkboard to emphasise the concepts.

#### Assessment

Ask learners to do exercise 7.2 given in the student's book page 213-214 question 8 and 9.

#### Answers to activity 7.7

Refer to the discussion given in the student's book page 210-212.

### Lesson 6: Alternative current (a.c) generators

#### Learning objective

By the end of this lesson, the learner should be able to explain the operation of an A.c generator.

#### Teaching aids

- Model of a.c generator

- Manila paper

### Introduction to the lesson

Review the energy conversions before defining what a generator is. Give practical areas where generators are used. A mention of a bicycle dynamo will go a long way in assisting the learners to do properly focused on the topic.

### Learning activities.

#### Teaching guidelines for activity 7.8

- In this activity, you may decide to use the groups formed in activity 7.7 or form the new groups. Note that when learners are working in groups, competences such as *cooperation*, *teamwork*, and *leadership skills* among others are enhanced.
- Ask learners to do Activity 7.8 in the student's book page 215, that is, to describe the working of an a.c generator. This activity should be performed to demonstrate the working of a.c generator. You may have to draw on a manila paper a chart the diagram of a generator to save on time. You may also need to model a generator for the learners to concretise the idea of a generator and its operation. Emphasis should be put on the slip ring comutators.
- Guide them through the activity to ensure they are doing the right thing. Then allow them to continue doing the activity on their own.
- Allow them to discuss their findings from the activity. This will promote *teamwork*, *cooperation*, *communication skills* *critical thinking* among other competences in learners.
- Hold a discussion with learners on

their findings on how an a.c generator works.

### Synthesis

Having done the activity holds a discussion with learners to emphasise the following facts:

- A current that flows back and forth in a circuit is called an alternative current.
- The number of cycles it completes in one second is known as the frequency of the alternating current and is measured in hertz.
- During the first quarter of rotation, the induced emf increases from zero to a maximum value or peak value.

### Assessment

Ask the students to attempt questions 4 and 6 in exercise 7.2 page 213-214.

### Answers to activity 7.6

Refer to the discussion given in the student's book page 208 - 209.

## Lesson 7: Root-mean-square (r.m.s) value

### Learning objective

The learner should be able to relate peak and root-mean square

### Teaching aids

- Mains power supply 2V, 50 HZ
- A ammeter
- Resistor 10  $\Omega$
- d.c and a.c power supply
- bulb 2.5 V, 0.3 A
- switch which selects between two

connections

- d.c power supply 3V

### Introduction to the lesson

In mathematics, learners have learnt how to find a square root of a number. They also learnt about power, that is  $P=IR^2$  in Senior 1 Physics. Using a small quiz establish whether the learners recall these concepts. Help them to remember what they learnt on these areas before learning about the root mean square in this section.

### Learning activities

#### Teaching guidelines for activity 7.9

- Organise learners into convenient groups depending on the availability of learning materials. Remember the groups formed should observe *different abilities* and *gender balance* in case of a mixed class.
- Once you have been satisfied by the group composition, ask learners to do activity 7.9 in the learner's book page 218 that is to deduce an expression for root-mean-square current.
- Go around the class to ensure that learners are doing the correct thing. Guide those with challenges especially in ensuring that the circuit is working.
- Allow learners to hold a discussion in their groups as they attempt to respond to all questions asked in the activity. This will promote cooperation, *communication skills* and *leadership skills* among other competences in the learners.
- Hold a class discussion with them on their findings especially the values they have obtained. Use their findings

whether right or wrong to guide them appropriately. At this point, remind the learners the importance of accepting and accommodating other people's opinion whether they agree with us or not. This is important since it will be promoting peace values in them.

### Synthesis

Having done the activity and discussed the learner's findings have a whole class discussion to emphasise the following facts:

- Root-mean-value is the steady direct current, which convert electrical energy to other form of energy in a given resistor at the same rate as the a.c.
- $E_{r.m.s}=0.707E^o$
- $V_{r.m.s}=0.707V^o$

Guide the learners in a discussion of example 7.6 given in the student's book page 220 to emphasise the use of root-mean value concepts.

### Assessment

Ask learners to do exercise 7.3 in the student's book page 220.

### Answers to activity 7.9

Mark the values of root-mean-value obtained by learners and refer to the discussion given in the student's book for further clarification.

## Lesson 8: Other applications of electromagnetic induction

### Learning materials

- Small external speakers

- Two stereo cables
- Small radio

### Teaching guidelines

Organize learners in pairs to do activity 7.10 in students book page 220-221 The teacher should always remember that it is good for learners to work in groups but those groups formed should reflect gender balance (incase of a class that comprises of boys and girls) and different abilities (slow learners and quick learners)

- Ask learners to do activity 7.10 in students book that is to establish the application of electromagnetic induction.
- After the learners have done the activity let them discuss their findings. Guide them appropriately.

### Synthesis

Hold a discussion with the learners on the facts discussed in the student's book.

Ensure that they master how an induction coil works.

Guide them through the discussion on the moving coil microphone as discussed in the student's book page 221 to 222.

### Assessment

Ask the learners to do exercise 7.4 in the student's book page 222-223.

### Answers to activity 7.10

Refer to the discussion given in the student's book page 221-222

### Summary of unit

- At random, ask different learners to lead others in brief discussion of

different concepts highlighted in the unit summary given the student's book page 223-224. By asking them probing questions, help them recall the concepts.

- Ask learners to go back to the unit focus activity given on pages 195-196. Let them now give the correct solutions to the questions asked therein. Since the questions have been answered at one instance within the unit, help them to understand how to give correct answers.

### Additional information

The teacher may find it important to guide the learner to construct a simple a.c generator or to convert electric motors to A.C generators. The output of the generator may then be connected to oscilloscope or a centre –zero galvanometer, to display the variation of e.m.f from the generator, emphasis on uniform rotation of coil, position of the coil when giving maximum or minimum induced e.m.f change in direction of the induced e.m.f as the coil rotates.

### Lesson 9: Unit assessment

Ask learners to do unit test 7 provided in the student's book pages 224-227, individually. Mark their work and hold a discussion on their results. This is important because it will help you as teacher to assess the *communication skills* when discussing the results and whether the learners have attained the objective of the unit. It will also help to promote **critical thinking** among them.

### Remedial questions for slow learners

1. Define the terms electromagnetic



induction.

2. What do you understand by the term emf?
3. State one observation when a magnet is passed through the coil connected to a galvanometer

#### Answers to remedial questions for slow learners

1. Electromagnetic induction (or sometimes just induction) is a process where a conductor placed in a changing magnetic field (or a conductor moving through a stationary magnetic field) causes the production of a voltage across the conductor.
2. Electromotive force, also called emf (denoted and measured in volts), is the voltage developed by any source of electrical energy such as a battery or dynamo. It is generally defined as the electrical potential for a source in a circuit.
3. The pointer of the galvanometer deflects.

#### Extended question for gifted learners.

1. Given magnets, conductors, connecting wires and galvanometer, describe how you can demonstrate the factors that affect the magnitude of emf induced.
2. Discuss briefly why you should learn the topic electromagnetic induction.
3. Design a simple a.c generator using the material available in your school or at home and demonstrate how it works to your classmate.
4. With the aid of a diagram explain the function of split and slip ring(s) in a generator.

#### Answers to extended questions for gifted learners

Mark the student's work and guide them appropriately. You may refer to the discussion given in the student's book or use internet and reference books.

#### Answers to numerical questions of exercises and unit test 7

##### Exercise 7.1

(Learner's book page 206-207)

9. 0.016 V
10. 7.85 MV
11. 1.5 MV

##### Exercise 7.2

(Learner's book page 213-214)

2.  $3 \times 10^{-3} \text{A}$
3. (a) 50 HZ  
(b) 659.4 V
6. 1 V
7. 2 V
8.  $1.5 \times 10^{-4} \text{V}$
9. 0.173V
10. (a) when  $\phi = 0$  and  $\frac{\Delta\phi}{\Delta t}$  is max  
(b) Yes, when  $\phi$  is max and  $\frac{\Delta\phi}{\Delta t} = 0$   
(c) 47 V
11. 0.75 V

##### Exercise 7.3

(Learner's book page 220)

1. (a) 9.9 A  
(b) 588 W
2. 12.9 A

# UNIT 8

## Electrical Power Transmission

Student's book pages 228-252 (10 Periods)

### Key Unit Competence

By the end of the unit, the learner should be able to analyse the transmission of electrical power.

### Prerequisite to this unit

For learners to acquire the knowledge, skills, altitude and values visualized in this unit with ease, they should have acquired the following concepts.

- Knowledge on simple electric circuit components, effect of electric current and applications of earth wire, fuse and circuit breaker and the skills on set up simple electric circuit. These concepts were learnt in S1 unit 12 on the topic of current electricity. The learners also have knowledge on work, power and energy and the skills of calculating and relating power and energy learnt in S2 unit 8 on the topic of work, power and energy. Using small quiz and then question and answer method ensure that learners recall and understand these concepts well before introducing this topic. This is important because the concept learnt prior to this topic will be helpful to the learners in understanding concepts to be learnt on electrical power transmission.
- Slight knowledge on transformers, electrical line and power plant. Learners may have a slight idea on what they are and the role they

play. Through question and answer method, the teacher should build on any idea on these concepts so that learner's curiosity of wanting to understand more is increased.

### Crosscutting issue to be addressed

The specific crosscutting issue to be addressed in the unit is:

- *Environment and sustainability:* Since the unit involves learning of how electrical power is produced then transmitted to various places of need, the learners at specific instance within the unit will learn how the construction of power plant can have negative impact to the immediate environment. It is important for learners to be aware of this because at a point in their lives, they may encounter with the situation either as an engineer working for the project, resident of the areas to be affected or any other citizen so that they can know how to respond appropriately for the benefit of all.

### Generic competences

The specific generic competences to be addressed in this unit include among others, the:

- *Critical thinking:* This competence will be achieved when the teacher will involve learners in doing activities especially the unit focus activity and answering questions in the exercises

8.1, 8.2, 8.3 and unit test 8 that require the learner to explain, discuss and describe the particular concept.

- *Teamwork, cooperation, personal and interpersonal management and life skills*: This competence will be achieved when the teacher will be organising the learners in groups to do different learning activities (that is, unit activities, project activity, doing exercises and unit test).
- *Communication skills*: The competence will be achieved when the teacher ensure that all learners are participating by giving their views in a discussion of different learning activities given in the unit.
- *Research and Problem solving*: This competence will be achieved when the teacher involve learners in activities that require the use of internet and reference books to find solutions to the task given.

### Vocabulary /Keywords

In the course of learning the concepts in this unit, the learners will discover the meaning of the following new words:

- Eddy current
- Hysteresis losses
- Magnetic flux leakage

Guide the learners to understand and explain these words in sentences relating to physics concepts.

### Guide on the problem statement

For learners to have a general idea of what they will be learning in the unit, the teachers should allow them to do the unit focus activity on their own.

### Teaching aids required

- A nearby transformer
- A nearby electricity transmission lines
- Questionnaire on electrical power transmission

### Learning activity for unit focus

- Organise learners into appropriate groups. Prompt them to see the need of having a group leader and secretary. This will promote **leadership skills** among the learners.
- Give each group the questionnaire you prepared for them. Let the question in the questionnaire be on the idea you want them to get from the observation when they will be visiting a nearby transformer and electricity transmission lines.
- Take them to nearby transformers and electricity transmission lines.
- Separate the groups and with the guidance of group leader and secretary, let them observe the transformer and electrical lines first then use the questionnaire provided to know what is required of them. Guide those who may be stranded to understand what they are supposed to do. Working in groups will not only promote **teamwork** but also **cooperation, leadership skills, organization skills** and **interpersonal relation** among the learners.
- Now ask them to go back to class. In the same groups, ask the learners to do unit focus activity given in the student's book pages 229-230.
- Allow learners to hold a discussion in their groups as they attempt to respond to all questions asked in the activity.

This will promote **communication skills** and among other competences in the learners.

- Use their feedback to guide them in such away that leads to the correct responses to the questions asked in the activity. The teacher can use probing questions. By doing that, you will be promoting the **critical thinking** of your learners.
- It is most likely that most learners will come up with different observation, explanation, and description that are inaccurate. At this point, show the learners the importance of accepting different opinions given by different learners whether right or wrong. This help to promote **peace** and **harmony** among the learners.
- Use their feedback to trigger their curiosity in order for them to see the need of learning more from the unit.
- Encourage those learners whom may have not responded correctly especially the slow learners that the correct answers will be obtained in the process of learning the unit , so that by the end of it, they will also be able to respond correctly to all questions asked in the unit focus activity and the questionnaire given.

#### Attention to special needs

In order to involve all learners in the learning process, you must know all your learners especially the special need in your class.

- The unit comprises of numerous activities, you should involve the special need learners in these activities. For example, those activities that require use of both eyes and hands, for

example activity 8.4 in the student's book pages 235-236, learners with sight challenges can use touch while those with disability of the hands (fingers or the hand as whole) can use their sight to observe and contribute during the discussion. Encourage the other student to accept and love learners with disability and not to threat them as those who are unable to participate in any learning activity. Remind learners that **disability is not inability**.

- For slow learners, organise remedial lessons for them. Guide them through the activities and exercise once again and more slowly to help them understand.
- Some of the questions in the exercises can be given to gifted learners. Prepare additional more challenging questions for them learners. (See remedial questions for gifted learners at the end of this Teacher's guide unit)

#### List of lessons

Lesson number	Lesson title	Number of periods
1	Structure and working of transformer	2
2	Types of transformers	1
3	Transformer equations	2
4	Power loses in a real transformer	1
5	Applications of transformers	2
6	Electric power transmission	1
7	Unit assessment	1
	Total	10

## Lesson Development

### Lesson 1: Structure and working of a transformers

#### Learning objective

The learner should be able to describe a transformer.

#### Teaching aids

- A transformer (within or near the school compound)
- Relevant Reference
- Computers with internet connectivity

#### Introduction to the lesson

In unit 7 of this book, learners already learnt about transformers. They learnt what a transformers is (i.e. an electrical device that transfers electrical energy from one circuit to another by electromagnetic induction) and the coils in the transformer (i.e. Primary and secondary coil). Using question and answer method, ensure that the learners recall these and others concept covered in unit 7 before introducing this part of the lesson. This is crucial because most of the concepts to be learnt require the good foundation of what the learners learnt.

#### Learning Activity

##### Teaching guidelines for activity 8.1

- The learners already made groups used in doing the unit focus activity. Ask learners to organise themselves into the same groups and do activity 8.1 given the student's book page 230. Ensure that no member move to a near group unless under certain circumstances. This is important because they may not need to go back

to the transformer once again as by the requirement of the activity but they can apply the concepts learnt and use the questionnaire given earlier to do the activity.

- Guide them through the activity and help them to do a constructive research from internet and reference books on transformer for more information.
- Allow them to discuss their observation from the activity. This will enable learners to realise the importance of teamwork and it will enhance communication skills in them.
- Go around to ensure that the main objective of this activity, that is, to describe the structure and working of a transformer is realised by learners.
- Hold a whole class discussion and ask the group secretaries to give the summarised report to the class. Use the opportunity to point out omissions and correct any error in each report presented.

#### Synthesis

- Learners having done the activity and discussed their finding with them, ensure they understand that:
  1. A transformer is an electrical device that transfers electrical energy from one circuit to another by electromagnetic induction.
  2. A transformer consists of two coils; primary and secondary coils.
  3. A transformer works on the principle of mutual induction
- Guide the learners through the discussion given in the student's book page 231 before asking them to do activity 8.2.



### Teaching guidelines for activity 8.2

- Still maintaining the same groups used in activity 8.1 or you may consider reorganise them, ask learners to do activity 8.2 in the student's book pages 231-232. It is important learners to work in groups but appropriate one (i.e., gender sensitive and of different abilities). The groups should be as small as possible in terms of membership to reduce cases of some members not participating. This will promote *leadership skills, cooperation and teamwork* among the learners.
- Go around to every group to ensure they are doing the right thing. Guide them through the activity. Ensure that all learners are included in the learning process. Those with the *disability of hands* should be given opportunity to observe and give their opinion during the discussion.
- Allow learners to hold a brief discussion on their observations and findings.
- Lead them through the whole class discussion on their findings. Correct any wrong responses given by learners.

### Synthesis

- Before you conclude this section of the unit, ensure that learners understand that
  1. Mutual induction is the production of an electromotive force in a circuit by a change in the current in an adjacent circuit that is linked to the first by the flux lines of a magnetic field.
  2. The circuit that induces electromotive force is called

primary circuit while the circuit in which the electromotive force is induced is called the secondary circuit.

3. The induced electromotive force in secondary circuit is in opposed direction accordance with Lenz's law.
- Now take the learners through the discussion given in the student's book pages 232-233 as you conclude this part.

### Assessment

Learns having done activities 8.1 and 8.2 and understood the concepts on structure and mode of action of transformers, Ask them to do question 1 (b) and (c) of exercise 8.1 in the student's book page 242. This will enhance critical thinking and problem solving skills in them.

**N/B:** See answers for the Exercise 8.1 at the end of this unit of the Teacher's guide.

### Answers to activity 8.1 student's book pages 230.

- In step 1, refer to the discussion given in the student's book.
- In step 2, A transformer is an electrical device that transfers electrical energy from one circuit to another by electromagnetic induction. Refer to the discussion given in the student's book for its structures .

### Answers to activity student's book pages 231-232

- In step 2, the galvanometer deflects. Refer explanation in the discussion given in the student book.
- In step 3, the galvanometer shows deflection. Refer explanation in the discussion given in the student book.



## Lesson 2: Types of transformers

### Learning objective

The learner should be able to explain the types of transformers.

### Teaching aid

- A transformer (within or near the school compound)
- Internet
- Reference books

### Introduction to the lesson

In the lesson 1 of this unit, the learners have learnt about the structure and working of transformer. They have already known that transformer work on the principle of mutual induction. Using question and answer method, introduce this part by first building on these and other concepts learnt. This is very important because it will help learners to analyse and discuss the other concepts to be learnt in this section.

### Learning Activity

#### Teaching guidelines for activity 8.3.

- Organise learners into appropriate groups depending on the availability of suggested materials. Prompt them to see the need of having a group leader and the secretary.
- Ask the group leaders and the secretaries to lead their members to a nearby transformer. This will promote *leadership skills, cooperation* and *teamwork* among the learners.
- Ask them to do activity 8.3 given in the student's book pages 233- 234, that is, to find out the types of transformers and their uses.

- Allow the learners to discuss their findings among themselves. Listen to how they discuss and guide them where necessary. This is important since it will give you opportunity to monitor and promote the *communication skills* of your learners.

### Synthesis

Hold a class discussion with learners to emphasize the following facts:

- They are two types of transformer; step down and step up
- Step down transformer has fewer turns in secondary coil than the primary coil and it is used to step down (decrease) large amount of voltage for use.
- Step up transformer has many turns in the secondary coil than in the primary coil and it is used to step up (increase) the amount of voltage for transmission.

### Assessment

Ask learners to do question 1 of unit test 1 in the student's book page 251.

**N/B:** See answers for the Unit test 8 at the end of this unit of the Teacher's guide.

#### Answers to activity 8.3 student's book page 233-234

- In step 1, the two types are step down and step up transformer
- In step 2, vandalism of transformers will cause a blackout. Mark appropriate explanation given by learners.

## Lesson 3: Transformer equation

### Learning objective

The learner should be able to explain operation and calculate the efficiency of transformer.

### Teaching aids

- Connecting wires
- Galvanometer
- A switch
- Insulated copper wire
- Source of current

### Introduction to the lesson

In mathematics, learners have learnt ratio, proportional and percentage. They have also learnt about the structure and working of transformers. Through a small quiz and question/answer method, ensure that the learners understand very well these and any other concepts learnt as an introduction. This is important since the section will require learners to recall and apply some of the concepts.

### Learning Activity

#### Teaching guidelines for activity 8.4

- Organise learners into appropriate groups, that is, if the class is a mixed one, ensure you have the gender balance (i.e., equally number of boys and girls if possible) and also they are of different abilities. This will help learners to appreciate the factor that all students (whether boys or girls) should be *given equal opportunity* to learn and also to promote *cooperation* among them.
- Ask the learners to do activity 8.4 given in the student's book pages 235-236.
- With your guidance, lead them through the steps of doing the activity. Help those who may be having difficulties.
- Give them few minutes to discuss their findings and let the group secretaries write down the main points from the discussion. This will promote *communication* and *leadership skills*.
- Hold a whole class discussion and ask the group secretaries to give the summarise report to the class. Use the opportunity to point out omissions and correct any error in each report presented.

### Synthesis

Now ensure that learners have understood the following facts:

- As the transformer is basically a linear device, a ratio now exists between the numbers of turns of the primary coil divided by the number of turns of the secondary coil. This ratio, called the ratio of transformation, more commonly known as a transformers "turns ratio", (TR ). This turns ratio value dictates the operation of the transformer and the corresponding voltage available on the secondary winding.
- It is necessary to know the ratio of the number of turns of wire on the primary winding compared to the secondary winding. The turns ratio, which has no units, compares the two windings in order and is written with a colon, such as 3:1 (3-to-1). This means in this example, that if there are 3 volts on the primary winding there will be 1 volt on the secondary winding, 3 volts-to-1 volt. Then we can see that if the ratio between the numbers of turns changes the resulting voltages must also change by the same ratio, and this is true.

- Transformers are all about “ratios”. The ratio of the primary to the secondary, the ratio of the input to the output, and the turn’s ratio of any given transformer will be the same as its voltage ratio. In other words for a transformer: “turns ratio = voltage ratio”. The actual number of turns of wire on any winding is generally not important, just the turns ratio and this relationship is given as:

$$\frac{N_p}{N_s} = \frac{V_p}{V_s} = n = \text{Turns Ratio}$$

- Efficiency of a transformer = power output / power input  $\times 100\%$
- The efficiency of an ideal transformer is  $100\%$ .
- Current passing through the coils of the transformer can be calculated using the equation,  $N_p I_p = N_s I_s$ .

Guide the learners through the discussion and examples 8.1-8.4 given in the student book pages 238-240. Ensure that learners have understood the working in the examples. Help those who may have challenges in the calculation.

### Assessment

Ask learners to do question 2 of exercise 8.1 in the student’s book page 243. Ensure that you have marked their work and guide them appropriately.

**N/B:** See answers for the Exercise 8.1 at the end of this unit of the Teacher’s guide.

### Answers to activity 8.4 student’s book page 235-236

- In step 4, the galvanometer deflects. Check and mark the reading obtained by learners.

- In step 6, the reading recorded was higher with more turns than less than. This is because the more the turn the more the emf induced .
- In step 7, refer to the discussion given in the student’s book page 236-237.

## Lesson 4: Power losses in a real transformer

### Learning objective

The learner should be able to outline and explain the reasons for power losses in a real transformer.

### Teaching aid

- Computers connected to internet (in extreme cases you can use cellphones)
- Physics reference books and any other relevant reference materials

### Introduction to the lesson

In this unit, learners have already learnt about transformer and its operation. They have done calculation on finding current, number of turns, power and efficiency. By the method of question and answer or a small quiz, establish whether the learners mastered these concepts as you introduce this section. Use probing questions such as does a transformer lose power? How? Let them attempt to answers. This is crucial because it will assist you to lay a good foundation for what the learners are about to learn in this section.

### Learning Activity

#### Teaching guidelines for activity 8.5

- By now the learners should be able to organise themselves appropriately into different groups without your

help whenever they are asked to do so. This does not mean you don't need to check and reorganise them where necessary. Therefore, organise them into appropriate groups depending the availability of suggested learning materials and let them be ready to do activity 8.5. Working in groups will enhance **personal and interpersonal management, teamwork and cooperation** among learners.

- Ask the learners to do activity 8.5 in the student's book page 240-241.
- With your guidance, lead them through the steps of doing a comprehensive research on factors that contributes to power losses i.e. resistance, eddy current, hysteresis losses, magnetic leakage from internet and reference books. Note that some student may open different sites such as Facebook, twitter and instagram thus deviating from the main object of the research. It is therefore important to go around the class and check whether they are doing the right thing. Knowing how to do constructive research is important to learners since it will be promoting their **research and problem solving skills** that will be useful in their life time (**lifelong learning**).
- Give them few minutes to discuss their findings and let the group secretaries write down the main points from the discussion. This will promote **communication and leadership skills**.
- Hold a whole class discussion and ask the group secretaries to give the summarise report to the class. Use the opportunity to point out omissions and correct any error in each report presented.

## Synthesis

- Having done the activity, guide them to understand that since electrical transformer is a static device, mechanical loss in transformer normally does not come into picture. We generally consider only electrical losses in transformer. Loss in any machine is broadly defined as difference between input power and output power. When input power is supplied to the primary of transformer, some portion of that power is used to compensate core losses in transformer i.e. Hysteresis loss in transformer and Eddy current loss in transformer core and some portion of the input power is lost as  $I^2R$  loss and dissipated as heat in the primary and secondary windings, because these windings have some internal resistance in them. The first one is called core loss or iron loss in transformer and the later is known as ohmic loss or copper loss in transformer. Another loss occurs in transformer, known as Stray Loss, due to Stray fluxes link with the mechanical structure and winding conductors.
- Now lead them to understand the discussion given in the student's book pages 241-242 on factors contributes to power losses and application of transformers.

## Assessment

Ask learners to do question 3 of exercise 8.2 given in the student's book page 249.

**N/B:** See answers for the Exercise 8.2 at the end of this unit of the Teacher's guide.

## Answers to activity 8.5 student's book page 241

1. In step 1, factors that contribute to power losses include resistance of the coils, eddy currents, hysteresis losses, Flux or magnetic leakage. Refer to explanation given in the student's book.

### Lesson 5: Applications of transformers

#### Learning objective

By the end of the lesson the learner should be able to state applications of a transformer.

#### Introduction to the lesson

Learners having covered the types of transformers and their calculations use questions and answers to evaluate if learners can be able to remember their concepts.

#### Learning Activity

- Review activity 8.5 in learners book page 240-241 use this activity to form a basis for this lesson. Ask learners to state some of the applications they may have noted from the previous activities.
- After the learners give their suggestions go through the discussion given on the student's book page 242 on applications of transformers.

### Lesson 6: Electric power transmission

#### Learning objective

The learner should be able to explain the electrical power transmission.

#### Teaching aids

- Cables of different thickness made of different metals

- Internet
- Reference books

#### Introduction to the lesson

In unit 7 of this book, learners learnt about the a.c generator and its operation. In this unit learners have already learnt on step up and step down transformers and their functions. Using question and answer method inquire whether the learners recall these concepts already learnt well. Guide them where necessary to ensure that the explanation given by learners is correct. This is important because it lays a foundation on the discussion of electric power transmission.

#### Learning Activity

#### Teaching guidelines for activity 8.6

- You have already grouped the learners before when they were doing activity 8.5, you may decide to maintain the groups for this activity or form new groups. Forming new groups sometimes is important because it helps learners to interact and share new ideas from different learners. It also promotes *teamwork, cooperation* among them.
- Provide the learners with the suggested materials
- Ask learners to do activity 8.6 provided in the student's book pages 244, that is, to describe the transmission of electric power.
- Guide them through the steps of the activity especially step 3 on conducting a comprehensive research from Internet and reference books.
- Go around checking whether the learners are doing the right thing.



Help those who may have difficulty in any step of the activity. Learners with *sight challenges* can be given the cables by the others to feel them and then determine their thickness.

- With your guidance, allow them to discuss their findings for a few minutes before asking the secretaries from each group to give a report to the whole class on their findings. This will promote *leadership* and *communication skills* in learners.
- Hold a class discussion on their findings and correct any errors (if any) in each report given. At this point, help learners to realise the importance of *accepting other people's opinion* whether they are *right or wrong* and *in case they disagree, let them do so constructively*. This will promote *peace* and *harmony* among the learners.

#### Synthesis

- Having discussed learner's findings from the activities, now lead the learners in the discussion to understand the following facts
- a. Transmission lines are sets of wires, called conductors that carry electric power from generating plants to the substations that deliver power to customers. At a generating plant, electric power is "stepped up" to several thousand volts by a transformer and delivered to the transmission line. At numerous substations on the transmission system, transformers step down the power to a lower voltage and deliver it to distribution lines. Distribution lines carry power to farms, homes and businesses. The type of transmission structures used

for any project is determined by the characteristics of the transmission line's route, including terrain and existing infrastructure.

- b. Due to electrical resistance of the transmitting cables, some electric power is lost.
  - i. To reduce power losses in transmission lines, very thick wires are used
  - ii. The transmission wires are made of metals like copper that are very good conductors of electricity.
  - iii. Electric current is transmitted at a very high voltage and low current.
- An a.c voltage can be easily and cheaply changed from one voltage to another by a transformer. The d.c voltage cannot.
- Guide them through the discussion given in the student's book pages 243-245 to emphasize the facts learnt.

#### Assessment

Ask learners to do question 1 of exercise 8.2 in the student's book page 247. Mark learner's work and guide them appropriately. This part will promote *critical thinking skills* among the learners.

#### Dangers of high voltage transmission

##### Teaching guidelines for activity 8.7

- Maintaining the same groups formed in activity 8.6, ask learners to do activity 8.7 given in the learner's book page 246.
- Guide them through the steps of conducting a research from Internet or reference book on the dangers associated with high voltage



transmission. This section of the unit is very important because it touches on the *safety of the student*. Ensure that the learners are doing constructive research. This will promote in the learners among other competences the *teamwork, cooperation* and *research skill*.

- Give learners few minutes to discuss their findings and let the group secretaries of each group give a summarised report on their findings.
- Lead the whole class in a discussion of their findings and allow the learners to point out the omission and errors (if any) in each report presented.

#### Synthesis

The learners having done the activity and discussed their findings now lead them to understand the following facts:

- The dangers of living or working near a high voltage power line includes
  - a. Risk of electric shock
  - b. Risk of fire outbreak
  - c. Childhood leukemia
  - d. Risk of getting cancer
  - e. Depression
- At this juncture, draw the learners to safety measures given in the student's book, that is, *Avoid touching loosely hanging electric cables. You will be electrocuted!!*

#### Assessment

Ask learners to do question 1 exercise 8.2 given in the student's book page 249. Mark their work and guide them appropriately. This will promote *critical thinking* in learners.

**Answers to activity 8.6 student's book page 244.**

- In step 1, the materials can be of copper or aluminium.
- In step 3, the water is drawn into the barrel of the syringe. Refer explanation given in the student's book.

**Answers to activity 8.7 student's book page 246**

In step 1, the dangers involves in transmission of high voltage are

- a. Risk of electric shock
- b. Risk of fire outbreak
- c. Childhood leukaemia
- d. Risk of getting cancer
- e. Depression

**Environmental impact of power generation and transmission**

#### Learning objective

The learner should be able to state dangers of staying near high voltage power lines.

- Reference books
- Internet

#### Learning Activity

**Teaching guidelines for activity 8.8**

- Organise the learners into appropriate groups depending on the suggested materials in the student's book page 248. The teacher should always remember that it is good for learners to work in groups but those groups formed should reflect **gender balance** (in case of a class comprises of boys and girls) and **different abilities** (slow and faster learners).

- Ask learners to do activity 8.8 in the student's book page 248, that is, to find out the environmental impact of power generation and transmission.
- Guide the learners on how to conduct a research from the internet. Note that some learners may open different sites from the expected one, therefore it is important for the teacher to go around and guide them properly. This will promote research skill in learners.
- Allow them to discuss their observation from the activity. This will enable learners to realise the importance of *teamwork* and it will enhance *communication skills* in them.
- Go around to ensure that the main objective of this section (i.e. Able to highlight and explain dangers associated with power generation and transmission) is realised by learners.
- Ask the learners to report their findings through their secretaries. Time may be insufficient, so let each group give a brief summary.

#### Synthesis

The learners having done and reported their findings hold a class discussion to emphasise the following facts:

- Some of the negative impacts associated with generation of electricity are:
  - a. Dislocation of people
  - b. Release of carbon dioxide
  - c. Disrupting ecosystem

Hold a discussion with the learners on the discussion given in the student's book to clarify the facts. At this point draw attention of the learners to the danger of malaria and how to prevent it.

#### Assessment

In groups, ask learners to attempt to answer the question on how the electricity transmission impacts the environment. Let them do it as homework. This question will promote critical thinking in learners. In addition, ask them to do Exercise 8.2 in the student's book page 249. Mark the work of learners and guide them appropriately.

#### Guidelines on Project work 8.1 in the student's book pages 250.

- Project work is vital in the learning process. It gives learners the opportunity to make use of their creativity and innovation acquired throughout their lives. It is important for the teacher to ensure his/her learners have done the suggested project.
- Group the learners appropriately and provide them with the following suggested materials: Dry cells, bulb, soft iron sheet, connecting wires, sheet of paper, insulated copper wires, masking tape.
- Ask them to choose a group leader and secretary.
- Let the group leaders and the secretaries lead others to do the project within two weeks.
- Within the two weeks, let the group leaders give the update of the progress of the project.
- Check the progress of the project twice a week before its completion. Guide the learners where necessary.
- After two weeks, let each group give a presentation on their project. Guide them appropriately.

### Answers to activity 8.8 student's book page 248.

- In step 1, some of the impacts of generation of electricity to environment are:
  - i. Dislocation of people
  - ii. Release of carbon dioxide
  - iii. Disrupting ecosystem

### Summary of unit

- At random, ask different learners to lead others in brief discussion of different concepts highlighted in the unit summary given the student's book page 250-251. By asking them probing questions, help them recall the concepts.
- Ask learners to go back to the unit focus activity given on pages 229-230. Let them now give the correct solutions to the questions asked therein. Since the questions have been answered at one instance within the unit, help them to understand how to give correct answers.

### Additional information to the teacher

It is important the teacher to know the following facts:

- Electrical power is generated at different generating stations. These generating stations are not necessarily situated at the load centre. To transmission the electrical power generated over a long distance has been one of the major challenges of the electrical age. The goals, which engineers have been working towards, have remained the same despite many other things changing over the years. They include

1. **Efficiency** - transport electric power over distance with minimal losses
2. **Safety** - transport power through urban and rural areas minimizing harm to people and animals.
3. **Cost** - use the minimal raw materials and building/operating costs possible
4. **Robustness** - create a system which is not vulnerable to surges from lightning, solar flares, earthquakes, ice storms, wind storms and have the system be able to 'heal' itself when outages occur, isolating problem area

### Lesson 7: Unit assessment

Ask learners to do unit Test 8 provided in the student's book pages 251-252, individually. Mark their work and hold a discussion on their results. This is important because it will help you as teacher to assess the **communication skills** when discussing the results and whether the learners have attained the objective of the unit. It will also help to promote **critical thinking** among them.

### Remedial activities/ questions for slow learners

1. Define the following terms:
  - i. Power station
  - ii. Mutual induction
  - iii. Efficiency of transformer
2. Name two coils found in a transformer
3. List three ways of reducing power loss in a transformer

- Name two environmental impacts of electrical power generation and transmission.

**Answers to activity/questions for slow learner**

- A power station, also referred to as a power plant or powerhouse and sometimes generating station or generating plant, is an industrial facility for the generation of electric power. Most power stations contain one or more generators, a rotating machine that converts mechanical power into electrical power.
  - Refer to explanation given in the student's book.
  - Refer to explanation given in the student's book
- Primary and secondary coils
- To reduce power losses in transmission lines,
  - a very thick wires are used
  - the transmission wires are made of metals like copper that are very good conductors of electricity.
  - electric current is transmitted at a very high voltage and low current.
- Dislocation of people
  - Disrupting ecosystem

**Extended activities/ questions for gifted learners**

- Explain the process of power transmission from power plant to homes.
- Discuss ways through which power generation and transmission has contributed to the growth of Rwanda's economy.

- Explain how the impact caused on the environment by the generation of electrical power and transmission of it can be reduced.

**Answers to the extended activities/ questions for gifted learners**

- Mark the student's work and guide them appropriately. Refer to the picture given in the student's book for guidance.
- By creating more jobs, improving security, used in industries for its operation among many others points. Mark the student's work and guide them appropriately.
- Refer to discussion given in the student's book. Let learners give variety of answers not necessary the one discussed in the student's book. Mark their work and guide them appropriately. Use the reference books and internet for more information.

**Answers to exercises and unit test 8**

**Exercise 8.1**

(Learner's book page 242-243)

- Step up transformer and step down transformer
  - A step down transformer has many turns in the primary and few turns on the secondary coil while a step up transformer has few turns in the primary coil and many turns in the secondary coil
  - Refer to discussion in students book
- $V_s = 60\text{v}$   $I_s = 10\text{A}$   
 Power =  $V_s I_s$   
 $P_o = 60 \times 10 = 600\text{W}$   
 Efficiency of transformer is 80%

$$\begin{aligned} \text{Power supplied} &= \frac{100\% \times 600\text{W}}{80\%} \\ &= 750\text{W} \end{aligned}$$

(b)  $P_v = 750$     $V_p = 240$  v

$$\begin{aligned} I_p &= \frac{P_i}{V_p} \\ &= \frac{750}{240} \\ &= 3.13 \text{ A} \end{aligned}$$

3. When the primary coil of a transformer is connected to a.c. mains the ac produces a changing magnetic flux in the iron core. The change in magnetic flux induces current in the secondary coil. The magnitude of this induced emf depends upon the number of turns in both coils.

4. Resistance of the coils  
Flux and magnetic leakage

5. (a) Step up transformer

(b) 400 V

(c) There is no power loss in the transformer

6. (a) A large current is carried in the primary coil thus should be made thicker to minimize power loss.

(b)  $V_p = 240$  v    $V_s = 9$ V    $N_s = 54$  turns

$$\begin{aligned} &= \frac{V_s}{V_p} = \frac{N_s}{N_p} \\ &= \frac{9\text{v}}{240} = \frac{54}{N_p} \end{aligned}$$

$$N_p = 1440 \text{ turns}$$

(c) There will be no emf induced in the secondary coil as there is no alternating current when 240v dc is used.

7. (a)  $N_p = 800$  turns

$N_s = 100$  turns

$V_p = 240$ v

$$\begin{aligned} &= \frac{N_s}{N_p} = \frac{V_s}{V_p} \\ &= \frac{100}{800} = \frac{V_s}{240} \end{aligned}$$

$$V_s = 30 \text{ V}$$

(b) Efficiency  $E = \frac{P_i}{P_o} \times 100$

$$= \frac{V_s I_s}{V_p I_p} \times 100\%$$

$$E = \frac{30 \times 0.72}{240 \times 0.10}$$

$$= 90\%$$

### Exercise 8.2

(Learner's book pages 249)

1. Mark learner's work accordingly

2. 0.048W

3. (a) (i) 66 A                      (ii) 5 A

(iii) 1 000 V                      (iv) 5 Kw

(v) 655 Kw

(b) (i) 66 A                      (ii) 33 A

(iii) 6 600 V                      (iv) 217.8 Kw

(v) 442.2 Kw

(c) – Resistance of the coils

– Eddy currents

– Hysteresis losses

– Flux or magnet leakage

4. – Using thick copper wires

– Transporting electricity in high voltage.

## Unit Test 8

(Learner's book page 251-252)

1. B

2. C

3. A

4. A

5. (a) Mutual induction is the effect of production of an emf in a coil because of change in current in a coupled coil.

(b) To reduce loss of current through magnetic leakage.

(c) A step up transformer is one with higher number of turns in the secondary than the primary coil while a step down transformer is one with lesser number of turns in the secondary coil and more turns in the primary coil.

(d) Transformers can only work with alternating current because without alternating current no emf can be induced in the coupled core.

6. (a)  $N_p = 400$  turns

$N_s = 10$  turns

$V_p = 250$ v

$I_p = 2.0$ A

$$= \frac{V_s}{V_p} = \frac{N_s}{N_p}$$

$$= \frac{V_s}{250 \text{ v}} = \frac{10 \text{ turns}}{400 \text{ turns}}$$

$V_s = 6.25$  v

(b)  $P_i = P_o; V_s I_s = V_p I_p$

$$6.25 \times I_s = 250 \times 2.0$$

$$I_s = 80 \text{ A}$$

(c) Refer to discussion given the student's book.

7. Refer to discussion given the student's book

8. (a)  $V_s = 12$  v  $N_p = 500$  turns

$N_s = 250$  turns

$$\frac{N_s}{N_p} = \frac{V_s}{V_p}$$

$$= \frac{250}{500} = \frac{12}{V_p}$$

$$V_p = 24\text{V}$$

(b)  $P = 40\text{W}$

$V = 12\text{V}$

$$I = \frac{P}{V}$$

$$= \frac{40}{12}$$

$$= 3.33\text{A}$$

(c)  $P = 40\text{W}$

$$\text{Efficiency} = \frac{P_i}{P_o} \times 100\% \%$$

$$\text{Power supplied} = \frac{100\% \times 40\text{W}}{90\%}$$
$$= 44.4 \text{ W}$$

9. (a) 95 000 W

(b) 2.88 A

(c) 6635.52 W

(d) 1600 V

(e) 2.88 A



**Electric Field Intensity**

Students book page 253-276 (9 Periods)

**Key Unit Competence**

By the end of this unit the learners should be able to calculate intensity of electric field due to one or more point charges.

**Prerequisites to this unit**

In a bid to make learners acquire the knowledge skills, attitudes and values stated in this unit with ease, there is need for learners to have acquired the following:

- Knowledge and understanding of the types of charges, how bodies get charged, and some basic laws of electrostatics like unlike charges attract and like charges repel learnt in Senior 1.

**Cross-cutting issues to be addressed**

The specific cross-cutting issues to be addressed in this unit are:

- Inclusive education; this unit has a wide range of activities that encourage inclusiveness of every learner. This is seen when making groups in that every member of the class will have a group and tasks for anyone of the members of the group.

**Generic competences addressed in this unit**

- Cooperation, interpersonal management and life skills through provision of group work.

- Communication through provision of learner's discussion based activities.
- Critical thinking and problem solving through involving the learners in problem solving and discussion.

**Vocabulary/keywords**

In the course of learning the concepts in this unit, the learners will discover the meaning of the following new words:

- Electrostatic force/ coulomb force.
- Superposition of forces
- Electric field intensity

Guide the learners to understand the meanings of these words and construct and speak out mathematical statements involving them in order to master their meaning and usage.

**Guidance on the problem statement**

In a way to make the learners get prepared and give attention to the unit, the teacher should organize learner to do the unit focus activity in groups, remember they already know something about electrostatics from S1 and S2.

**Unit focus activity**

- Divide the students into small groups, for example a group of 4-5.
- Ask them to draw the magnetic field pattern between positive and a negative charges and between two positive charges.

- Ask them to explain the meaning of electric field intensity, and state the factors that determine its magnitude.
- Ask them to compare the electric field intensity around three charges in fig 9.1 page 254.
- Ask them to answer questions on number three using fig 9.2 page 255.
- Ask one person from each group to discuss briefly to the whole class their findings to the class.

#### Synthesis

- Allow the learners to hold discussions in their groups in a way to answer the set questions. Working in groups improves their **communication skills** and **cooperation**.
- It is most likely that some will come up with the right answers as they studied it in S2 and some like weak learners may not.
- From their discussion, use that feedback to trigger their curiosity in order for them to see the need to learn more from the unit.
- Encourage the learners more especially the slow learners that the correct answer will be obtained in the process of learning the unit so that by the end of it, they can be able to respond correctly to all the questions asked in the unit activity.

#### Attention to special needs

- You should provide for learning of all learners including those with special needs.
- The calculations in this unit may not be challenging to the specially gifted

learners hence they may finish doing the task so fast then get bored and start distracting others. Prepare additional more challenging questions for these learners.

- For the slow learners, organize remedial lessons where you guide them through the activities once again and more slowly to help them understand the concepts.

#### List of lessons

Lesson No.	Lesson Title	No. of periods
1.	Electrostatic force and coulomb law	1
2.	Superposition of forces	1
3.	Electric field	2
4.	Electric field intensity	2
5.	Electric field patterns	1
6.	Unit assessment	2
	Total	9

Remember one period was about the problem statement activity

#### Lesson Development

##### Lesson 1: Electrostatic force and coulombs law

#### Learning objective

The learners should be able to appreciate the applications of electrostatic force, define it and solve problems related to it.

#### Teaching Aids

- Two identical polythene rods A and B
- clamp and a stand
- silk cloth
- Thread.

## Introduction to the lesson

Before the lesson, prepare a set of the materials mentioned above for each of the groups that will be formed.

Introduce the lesson by using question and answer method to guide the learners to review the definition of electrostatic force and statement of coulombs law as learnt in previous lessons.

## Learning Activities

### Teaching guidelines for Activity 9.1

- Organize the learners into convenient groups to do activity 9.1 as outlined in the student's book page 255. The activity is meant to show the learners the force of repulsion between negatively charged polythene rods.
- Let them know that if bodies were charged differently and they have unlike charges, the force between them is an attraction force.
- Ask them to state the effect of amount of charge on the force of repulsion, and discuss their observation made with the other members in the group. Let them choose one person to present to the class in a few minutes. Such discussions will improve their communication skills.

### Synthesis

- Having done the activity, guide the learners through a class discussion to understand that when the distance of separation increases between charged bodies, even the force reduces but as the distances becomes shorter, the force increases. The other observation is that if the amount of charge increases, the force of repulsion also increases as well.

- Let them know that coulombs law states that the force of attraction or repulsion between two electrically charged particles is directly proportional to the magnitude of their charges and inversely proportional to the square of the distance between them.
- Guide them in a discussion on example 9.1 and 9.2 in the student book pages 256-257

### Assessment

- Ask the learners to do exercise 9.1 in the students book pages 257-258.

### Answer to activity 9.1

- In step 3, there is repulsion between the rods where rod A will be pushed away. The repulsion increases as rod B gets near rod A that is to say, when it is closer to A, there is more repulsion.
- In step 4, there is still repulsion but here rod A is pushed further at the same distance near rod B. And when it is brought closer, it is seen to be pushed further than before.
- In step 5, it is clearly seen that when the rods are charged vigorously, the force of repulsion between the two charged rods increases.

## Lesson 2: Superposition of forces

### Learning objective

The learner should be able to state the superposition principle for point charges in an electric field and explain superposition of parallel electric fields.

## Teaching Aids

- Reference materials including books..
- internet

## Learning Activities

### Teaching guidelines for Activity 9.2

- Ask learners to activity 9.2 given in the student's book page 258 to research from the internet and text books the principle of superposition for point charges in an electric field and explain superposition of parallel electric fields.
- Ask them individually to present to the class their findings.

### Synthesis

- Having done the activity, help the learners through a class discussion to appreciate that for a number of forces, the net force on any one charge is simply the vector sum of the forces exerted on it by the other charges. This is what is termed as the superposition principle (superposition property), which states that for all linear forces the total force is a vector sum of individual forces. This principle holds for linear systems.
- Guide the learners through examples 9.3 and 9.4 discussed in the learner's book pages 259-260.

### Assessment

- Ask the learners to do exercise 9.2 provided in the student's book pages 260-261.

### Answer to activity 9.2

- In step 1 and 2, the superposition of forces is a principle that is applied when getting the resultant or net

force on a charge when more than two charges are present. It states that for all linear forces, the total force is a vector sum of individual forces.

## Lesson 3: electric field

### Learning objective

The learner should be able to explain and differentiate electric field and electric force and describe electric field patterns for two point charges.

### Learning activity

### Teaching Aids

- Internet enabled computers
- Related books

### Introduction to the lesson

Introduce the lesson by using question and answer method to guide the learners to review the meaning of an electric field.

### Teaching guidelines for Activity 9.3

- Organize them in pairs
- Ask them to do activity 9.3 on doing research on electric field as outlined in the student's book page 261.

### Synthesis

Use a class discussion to the learners come up with the best definition of electric field. Help them to consolidate that a charged object affects other objects without touching them in what is called action at a distance which is explained by electric field.

### Answer to activity 9.3

- In step 1, an electric field is the region where a charged body experiences a force

## Teaching guidelines for activity 9.4

### Teaching aids required

- Glass dish
- Castor oil
- Electrodes
- Connecting wires

### Learning activity

#### Preparation for the lesson

Before the lesson, prepare a set of the materials mentioned above for each of the groups that will be formed.

In case you cannot get grass seeds, you can also use semolina powder.

#### Teaching guidelines for Activity 9.4

- Organize the learners into convenient groups.
- Ask them to do activity 9.4 as outlined in the students' book page 261-262. This activity is meant to show the learners and demonstrate to them the electric fields produced by charged bodies.

#### Synthesis

Use a class discussion to help the learners consolidate the facts in order to clearly understand that;

- The alignment of glass seeds as seen in the experiment represents the electric field produced by different arrangement of charges as outlined in the student book page 262-263.
- An electric field is a region or space surrounding a charge where a charged body experiences a force.
- A body which is charged or not when brought into the electric field of a

charged body, may be attracted or repelled away.

#### Answers to activity 9.4

- In step 4, the seeds spread and appear like in Fig.9.7 (a) in the student book on page 262.
- In step 5 and 6, the seeds spread and appear like in Fig.9.7 (b), (c), (d), (e), and (f) on page 262 - 263.

## Teaching guidelines for activity 9.5

### Teaching aids required

- Internet
- Reference books

### Learning activity

#### Teaching guidelines for Activity 9.5

- Divide learners into pairs.
- Ask them to do activity 9.5 on determining the direction of electric field and the line of force as outline in the student's book on page 264.
- Ask them to discuss the properties of electric lines of force with the rest of the class

#### Synthesis

Through a class discussion, help all the learners appreciate that;

- Electric fields may be represented by electric field lines.
- The direction of the electric field at a particular point is defined as the direction in which the unit positive charge is free to move when placed at that point or the direction of the force on a small positive charge placed at the point.

- An electric field line is a line drawn in an electric field such that its direction at any point gives the direction of the electric field at that point or is the path along which a unit positive charge would tend to move if placed at that point.
- The properties of electric field lines as outlined in the student's book on page 265.

#### Answers to activity 9.5

- In step 1, electric line of force is the path along which a unit positive charge would tend to move if placed at that point and the direction of the electric field line is defined as the direction in which the unit positive charge is free to move when placed at that point or the direction of the force on a small positive charge placed at the point.

### Lesson 4: Electric field intensity

#### Learning objective

The learner should be able to explain the intensity of electrical field to the position of charge and electric field intensity due to a charge.

#### Teaching Aids

- clamp and a stand
- polythene rod
- pith ball
- A string.

#### Introduction to the lesson

Introduce the lesson by using question and answer method to guide the learners to review the meaning of an electric field.

#### Learning Activities

##### Teaching guidelines for Activity 9.6

- Organize the learners into convenient groups.
- Guide them to do activity 9.7 given in the student's book pages 265-266 on the effect of the distance and the quantity of charge on electric field strength.
- Prompt them to conclude on the strength of the electric field basing on their observations from the experiment on quantity of charge and distance from the charge.
- Encourage the learners to share their findings to the rest of the class

#### Synthesis

Use a class discussion to help learners consolidate the facts in order to clearly;

- Understand that Electric field intensity is the measure of the strength of an electric field at a specified point. It is defined as the electrostatic force per unit charge experienced by a test charge placed at a specified point in an electric field.  
Its SI unit is Newton per coulomb (N/C) or volts per meter.
- Factors that determine the magnitude of electric field intensity as discussed in the student book on page 266-268.
- Another expression for electric field intensity in terms of electric field potential (V) as the work done in moving a unit charge through a distance  $d$  in an electric field. Thus, other units of electric field intensity are volts per meter.



- Guide the learners through Example 9.5 and 9.6 in the student book 3 on page 268-269.

#### Assessment

- Ask the learners to do Exercise 9.3 given in the students book pages 269-270.

#### Answers to activity 9.6

- In step 4, when the distance is (point A), there is repulsion between the pith ball and the polythene rod
- In step 5, at point B, 6 cm point C, 4 cm and D 2 cm, there is repulsion but greatest at point D and C.
- In step 6, there is still repulsion but here they move fast from each other and its greatest at point D, and C. The repulsion in step five is not as strong as that of step 6 that is to say the pith ball is pushed further in step 6 than 5 thus more repulsion in step 6.

### Lesson 5: Electric field patterns

#### Learning objective

By the end of the lesson the learner should be able to show electric field patterns for isolated and non-isolated bodies.

#### Teaching aids required

- Reference books
- Internet

#### Introduction to the lesson:

Learners having covered the lesson on electric field lines, they are able to draw the different electric field lines. Use questions and answer method or a small quiz to remind the learners on how they are drawn before you start this lesson.

#### Learning activity

#### Prerequisite to the lesson

Introduce the lesson by asking the learners to define electric field and electric field line.

#### Teaching guidelines for Activity 9.7

- Organize the learners into pairs.
- Ask them to do activity 9.7 on drawing electric field patterns as outlined in the student book on page 270.
- Encourage the learners to discuss their findings with the rest of the class.

#### Synthesis

Through a class discussion, help the learners appreciate that;

- The field lines are radially outwards for an isolated positive charge
- The field lines are radially inwards for an isolated negative charge
- There is always a neutral point in between two equal charged bodies of the same charge as outlined in the student's book page 270-273.

#### Answers to activity 9.7

- In step 1, the diagrams of Fig.9.14-9.20 and Fig.9.12 can be used as provided in the student book page 270-273.
- In step 2, the diagram of Fig.9.13 and Fig.9.14 given in the student's book page 243 can be used.

#### Summary of Unit

Summarize the unit by:

- Asking different learners to take the class through the different concepts highlighted in the unit summary given in the learner's book page 273-274. Ask the class probing questions to help them recall the concepts correctly.

- Ask the learners to now describe a solution to the unit focus activity at the start of the unit.
- Guide the learners to draw the electric field patterns between a positive charge and negative point charge, and two positive charges but making sure they get involved. In fact they should discuss as a class and they come up with answers.
- Guide them to appreciate that electric field intensity is the measure of the strength of an electric field at a specified point. Let them know that it can also be defined as the electrostatic force per unit charge experienced by a test charge placed at a specified point in an electric field.
- Let them understand that the factors that affect the magnitude of electric field strength are the distance of a point in the electric field from the charge and the quantity of charge.
- Let them realize that when the field lines are close to each other, it means that the electric field is very strong and if they are far from each other, it means the electric field is weak.
- Guide them in answering question three of the unit focus activity by letting them discuss. Make sure that the force between the pith ball and the positively charged sphere A is and it is towards right (attraction) and that between the pith ball and the negatively charged sphere B is to the left (repulsion). The resultant force on the pith ball is to the left. Let them know that we subtract because the forces are going in different directions.
- Let them know that the principle of superposition is the one used in the previous number.

### Additional information to the teacher

- It is important as a teacher to know following facts:
- The negative charge of the electron is equal but opposite to the positive charge of the proton. These charges are referred to as electrostatic charges.
- Electric flux through an area is defined as the electric field multiplied by the area of the surface projected in a plane perpendicular to the field.
- Gauss's law of electrostatics states that the total of the electric flux out of a closed surface is equal to the charge enclosed divided by the permittivity.
- Some problems of electric field can be solved using

$$\text{Electric field intensity (E)} = \frac{\text{Electric field potential V}}{\text{distance (d)}}$$

$$E = \frac{Q}{4\pi\epsilon_0 d^2}$$

Thus, other units of electric field intensity are volts per meter.

### End of unit assessment

- Ask the learners to do Unit Test 9 given in the student book page 274-276.

### Remedial activities for slow learners

1. Two negatively charged balloons are suspended from non conducting strings being held by a student. What occurs as the student brings the balloons closer to each other without allowing them to touch?
  - A. The magnitude of the electrostatic force between the balloons decreases, and they attract each other

- B. The magnitude of the electrostatic force decreases and they repel each other
- C. The magnitude of the electrostatic force increases and they attract each other
- D. The magnitude of the electrostatic force between the balloons increases and they repel each other
2. When a glass rod is rubbed with silk and the glass rod becomes positively charged
- A. Electrons are removed from the rod
- B. Protons are added to the silk
- C. Protons are removed from the silk
- D. The silk remains neutral
3. What variable(s) affect the magnitude of the electrostatic force between two objects with charge?
- A. The charge of the first object
- B. The charge of the second object
- C. The distance between the charges
- D. All of the answers
2. Two point charges, initially apart, are moved to a distance of  $\frac{1}{4}$  apart. By what factor does the resulting electric force between them change?
- A. 4                      B. 16
- C.  $\frac{1}{4}$                       D.  $\frac{1}{16}$
3. Four positive charges, each have a charge of  $1.0 \times 10^{-6}$  C, are arranged to form a 20.0 cm wide square. Find the strength of the electric field at the center of the square
- A. 16.0 N/C      B. 4.0 N/C
- C. 0 N/C              D. 2.0 N/C

**Answers for remedial questions for gifted learners**

1. A.
2. D.
3. C.

**Answers to exercises and the Unit Test**

**Answer to exercise 9.1 (page 257-258)**

1. 1.994 m
2. 0.021 m
3. 129.6 N
4.  $5.12 \times 10^{-10}$  N
5.  $9 \times 10^3$  N
6.  $2.304 \times 10^{-10}$  N
7.  $7.4649 \times 10^{-8}$  N
8.  $2 \times 10^{-9}$  C
9.  $3.6 \times 10^4$  V
10.  $2.7 \times 10^{-2}$  N

**Answer to exercise 9.2 (page 260-261)**

1. 0.009 N
2. 14.2 N

**Answers to remedial activities for slow learners**

1. D
2. A
3. D

**Remedial questions for gifted learners**

1. If the charge is quadrupled for each of two identical charges maintained at a constant separation, the electric force between them will be changed by what factor?

- A. 16                      B.  $\frac{1}{16}$
- C.  $\frac{1}{8}$                       D. 8

3. (a)  $1.125 \times 10^{14}$  N  
 (b)  $1.125 \times 10^{13}$  N  
 (c)  $3.7125 \times 10^{14}$  N

**Answer to Exercise 9.3 (page 269-270)**

1. C  
 2. D  
 3. A  
 4. D  
 5. D  
 6. 120 N, Downwards, 90 N upwards.  
 7.  $2.4 \times 10^{-4}$  joules

**Answers to Unit test**

1. A  
 2. A  
 3. C  
 4. A  
 5.

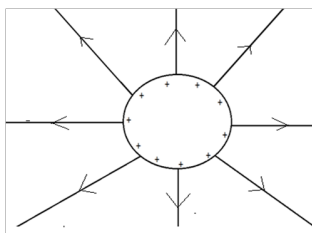

- (a) To the left  
 (b) To the right

6. Applying Coulomb's law, the force between the charge (Q) and the unit charge (q) is given by

$$F = \frac{Qq}{4\pi\epsilon_0 d^2}$$

Thus the electric field intensity = force exerted on unit charge q by charge Q given by

$$E = \frac{\text{Force exerted}}{\text{charge}}$$

$$= \frac{Qq}{4\pi\epsilon_0 d^2 \times q}$$

$$E = \frac{Q}{4\pi\epsilon_0 d^2} Q \text{ (on crossing out } q)$$

7. 0.00028 J  
 8.  $6.25 \times 10^{18}$  N/C  
 9. 240N  
 10.  $5.6 \times 10^{-15}$  N  
 11. 108 J  
 12.  $1.6 \times 10^{-15}$  N  
 13. 874.5 N/C  
 14. 122.5 V

### Key Unit Competence

By the end of the unit the learner should be able to analyse and carry out a simple electric installation.

### Prerequisite to this unit

For learners to acquire the knowledge, skills, attitude and values required in this unit with ease, they should have acquired the following concepts.

- Knowledge on simple electric circuit components, effect of electric current and applications of earth wire, fuse and circuit breaker and the skills on set up simple electric circuit. These concepts were learnt in S1 unit 12 on the topic of current electricity. The learners also have knowledge on lightning arrestor, arrangement of resistors, and on basic electronic components learnt in units 12, 13 and 15 in Physics S2 respectively. Additionally, the learners should have attained the skills of constructing simple electric circuit with resistors in series and parallel, ammeter and voltmeter. These concepts are important for this unit since most of the discussion therein will require the application of what the learner have already learnt.
- Knowledge on generation and transmission of electrical power learnt in unit 8 of this book. Through question and answer method, the teacher should build on any idea

on these concepts so that learner's curiosity of wanting to understand more is increased.

### Crosscutting issue to be addressed

The specific crosscutting issue to be addressed in the unit is:

- **Financial education:** Since the unit involves learning of how electrical power is connected to our homes for use, the learner's attention at specific point within the unit has been drawn to the using of energy saver bulb to minimise costs from electricity bills. It is important for learners to be aware of this because they interact and use electrical power in daily basis.
- **Comprehensive sexuality education:** since the unit is about house electric installation, at one point within the unit the student are asked to explain how to do wiring of VCT house. At that point they have drawn to attention of being safe from sexually transmitted diseases such as HIV and AIDS. This is crucial information for the student. The teacher should use the opportunity to sensitize learners about HIV and AIDS.

### Generic competences

The specific generic competences to be addressed in this unit include among others the:

- **Teamwork, cooperation, personal and interpersonal management and life skills:** This competence will be

achieved when the teacher will be organising the learners in groups to do different learning activities (that is, unit activities, project activity, doing exercises and unit test).

- **Research and Problem solving:** This competence will be achieved when the teacher involve learners in activities that require the use of internet and reference books to find solutions to the task given.
- **Communication skills:** The competence will be achieved when the teacher ensures that all learners are participating by giving their views in a discussion of different learning activities given in the unit.
- **Critical thinking:** This competence will be achieved when the teacher will involve learners in doing activities especially the unit focus activity and when answering questions in the exercises 10.1, 10.2, and unit test 10 that require the learner to explain, discuss and describe the particular concept.

### Vocabulary/Keywords

In the course of learning the concepts in this unit, the learners will discover the meaning of the following new words:

- Sizing
- Incandescent and LED lamps
- Braided conductor

Guide the learners to understand and explain these words in sentences relating to physics concepts.

### Guide on the problem statement

For learners to have a general idea of what they will be learning in the unit, the

teachers should allow them to do the unit focus activity on their own.

### Teaching aids required

- Manila paper
- Geometrical set

### Learning activity for unit focus

- Organise learners into appropriate groups. Prompt them to see the need of having a group leader and secretary. This will promote *leadership skills* among the learners.
- Provide them with the manila paper and ask them to do unit focus activity given in the student's book page 278.
- Allow learners to hold a discussion in their groups as they attempt to respond to all questions asked in the activity. This will promote *cooperation, communication skills* and *leadership skills* among other competences in the learners.
- Use their feedback to guide them in such away that leads to the correct responses to the questions asked in the activity. The teacher can use probing questions. By doing that, you will be promoting the *critical thinking* of your learners.
- It is most likely that most learners will come up with different observation, explanation, and description that are inaccurate. At this point, show the learners the importance of accepting different opinions given by different learners whether right or wrong. This help to promote *peace* and *harmony* among the learners.
- Use their feedback to trigger their curiosity in order for them to see the need of learn more from the unit.



- Encourage those learners who may have not responded correctly especially the slow learners that the correct answers will be obtained in the process of learning the unit so that by the end of it, they can be able to respond correctly to all questions asked in the unit focus activity.

### Attention to special needs

In order to involve all learners in the learning process, you must know all your learners especially the special need in your class. The following are some suggested ways on how to involve them in learning activities.

- Some of the questions in the exercises can be given to gifted learners. Prepare additional more challenging questions for the learners. (See remedial questions for gifted learners at the end of this Teacher's guide unit).
- For slow learners, organise remedial lessons for them. Guide them through the activities and exercise once again and slowly to help them understand.
- The unit comprises of numerous activities, you should involve the special need learners in these activities. For example, those activities that require use of both eyes and hands, for example activity 10.3 in the student's book page 283, learners with sight challenges can use touch while those with disability of the hands (fingers or the hand as whole) can use their sight to observe and contribute during the discussion. Encourage the other student to accept and love learners with disability and not to threat them as those who are unable to

participate in any learning activity. Remind learners that *disability is not inability*.

### List of lessons

Lesson number	Lesson title	Number of periods
1	Standard symbols for electrical installation	1
2	Electrical lamps and fuses	2
3	Types of electrical cables and their sizes	2
		1
4	Household wiring	2
		1
5	Dangers of electricity	2
6	Unit assessment	1
	Total	12

### Lesson Development

#### Lesson 1: Standard symbols for electric installation

#### Learning objective

The learner should be able to describe symbols used for electrical engineering drawing.

#### Teaching aids

- Fuses of different rating
- A switch
- A socket
- A bulb
- Chart showing standard symbols for electrical installation

## Introduction to the lesson

In unit 7 of this book, learners already learnt about transformers. They learnt what a transformer is (i.e. an electrical device that transfer electrical energy from one circuit to another by electromagnetic induction) and the coils in the transformer (i.e. Primary and secondary coil). Using question and answer method, ensure that the learners recall these and others concept covered in unit 7 before introducing this part of the lesson. Prompt them to see if they can remember how they represented a transformer in an electric circuit. This is crucial because most of the concepts to be learnt require a good foundation of what the learners learnt.

## Learning Activities

### Teaching guidelines for activity 10.1

- Organise learners into appropriate groups depending on the availability of suggested materials. Prompt them to see the need of having a group leader and the secretary.
- Ask the group leaders and the secretaries to lead their members to do activity 10.1, that is, to identify standard symbols for electrical installation in the student's book page 279. This will promote **leadership skills, cooperation** and **teamwork** among the learners.
- Allow the learners to discuss their findings among themselves. Listen how they discuss and guide them where necessary. This is important since it will give you an opportunity to monitor and promote the **communication skills** of your learners.

- Go around to ensure that the main objective of this activity, that is, to identify standard symbols for electrical installation.
- Hold a whole class discussion and ask the group secretaries to give the summarised report to the class. Use the opportunity to point out omissions and correct any error in each report presented.

### Synthesis

- Learners having done the activity and discussed their finding with them, emphasise the facts that electrical symbols are used to represent various electrical and electronic devices in a schematic diagram of an electric circuit.
- Guide the learners through the discussion given in the student's book page 279-280. Ensure they have understood the electrical devices and its symbol in table 10.1. Emphasise how the symbol are used in electrical circuit.

### Assessment

Ask learners to do question 1 of exercise 10.1 in the student's book page 285. Make their work and guide them appropriately.

### Answer to activity 10.1 student's book page 279

1. In step1, mark the learner's drawing and guide them properly.
2. In step 2, the use of a fuse is to protect electrical appliance by blowing off when large current pass through the appliance. The use of switch is to allow and cut off current in an electric circuit. The use of circuit breaker is to interrupt current flow in electric

circuit whenever there is a fault with the circuit thus protecting the house and electrical appliances. A socket is used for electrical connection to appliance. And a bulb is used for lighting.

3. In steps 3, refer to the discussion given in the student's book pages 279-280. Discuss with the learners the standard electrical symbols used in electrical installation.

## Lesson 2: Electric lamps and fuses

### Learning objective

The learner should be able to identify different types of lamps and fuses as well as explain their uses.

### Teaching aid

- Different types of electrical lamps
- Reference books
- Internet enabled computers

### Introduction to the lesson

In S1 unit 12, learners learnt about electric components and their symbols such as a bulb in simple circuit. They also learnt about the functions of fuses and circuit breakers. Using question and answer method, introduce this part by first building on these and other concepts learnt. This is very important because most of the concepts to be discussed in these unit will require the application of what the learners learnt.

### Learning Activity

#### Teaching guidelines for activity 10.2

- Organise learners into appropriate groups, that is, if the class is mixed,

ensure you have the gender balance (i.e., equally number of boys and girls, if possible) and also they are of different abilities (slow and gifted learners). This will help learners to appreciate the factor that all students (whether **boys** or **girls**) should be **given equal opportunity** to learn and also to promote the sharing of ideas and **cooperation** among them.

- Ask the learners to do activity 10.2 given in the student's book page 280, that is, to observe and describe the types of electrical lamps used for lighting.
- With your guidance, lead them through the steps of doing a comprehensive research on types of electrical lamps used for lighting. Note that some student may open different sites such as Facebook, twitter and instagram thus deviating from the main object of the research. It is therefore important to go around the class and check whether they are doing the right thing. Knowing how to do a constructive research by learners is important since it will be promoting their research and problem solving skills that will be useful in their life time (lifelong learning).
- Give them few minutes to discuss their findings and let the group secretaries write down the main points from the discussion. This will promote communication and leadership skills.
- Hold a whole class discussion and ask the group secretaries to give the summarise report to the class. Use the opportunity to point out omissions and correct any error in each report presented.

### Synthesis

Hold a class discussion with learners to emphasize the following facts:

- Electrical lamp is a light emitting electrical device used for lighting and indicating.
- The filament of a lamp is made of tungsten since it has a high melting point.
- There are three main categories of lamps; incandescent LED and gas-discharge lamps.

### Teaching guidelines for activity 10.3

- Still maintaining the same groups used in activity 10.2 or you may consider reorganise them, ask learners to do activity 10.3 in the student's book pages 283, that is, to find out what a fuse is and its functions.
- Go around to every group to ensure they are doing the right thing. Guide them through the activity. Ensure that all learners are included in the learning process. Those with the *sight challenge* should be given fuses to hold while the other learners study them keenly.
- Allow learners to hold a brief discussion on their observations and findings.
- Lead them through the whole class discussion on their findings. Correct any wrong responses given by learners.

### Synthesis

Hold a class discussion with learners to emphasize the following facts:

- A fuse is a short thin piece of wire of low melting point. It melts when a

large current flows through it, thus safeguarding the electrical appliances.

- Fuse rating is the current needed to blow up (break) the fuse.

### Teaching guidelines for activity 10.4

- Let learners maintain the same groups used in activity 10.3.
- Ask them to do activity 10.4 given in the student's book page 284, that is, to describe the working of circuit breakers.
- Guide them through the steps of the activity and allow them to discuss their observation.
- Ask the group secretaries to report to the whole class their finding. This is important because it will promote *communication* and *leadership skills* in learners.

### Synthesis

Hold a class discussion with learners to emphasize the following facts:

- Circuit breakers are an automatically operated electrical switch designed to protect electrical appliances by interrupting current flow in case an electric fault is detected.

### Assessment

Learners having done and discussed the concepts in this section, ask them to do questions 2-6 of exercise 10.1 in the student's book page 285-286. Make their work and guide them appropriately.

**N/B:** See answers for these questions of exercise 10.1 at the end of this unit of the Teacher's guide.

### Answers to activity 10.2 student's book page 280

- In step 1, 2 and 4 refer to the discussion given in the student's book.

### Answers to activity 10.3 student's book page 283

- In step 1, the fuse is a short thin piece of wire of low melting point. It is used to prevent dangerously large current from flowing.
- In step 2, check the rating of the fuse given to learners and mark their answers. Guide them appropriately.

### Answers to activity 10.4 student's book page 284

- In step 2, the light goes off and on respectively. Refer to the discussion given in the learner's book.
- In step 3, refer to the discussion provided in the learner's book.

## Lesson 3: Type of electrical cables and their sizes

### Learning objective

The learner should be able to describe the cable by type and size used for lightning arrestor, lighting and socket outlets.

### Teaching aids

- Electrical cables
- Internet
- Reference books

### Introduction to the lesson

At home and school, learners may have seen, touched or interacted with different wires or cables. Introduce this part by asking learners to suggest what cables are, type of cables, their structure and functions. Use their suggestions (whether

wrong or right) to trigger their curiosity of understanding concepts about cables. The teacher should also use question and answer method to finding out whether learners can recall and explain well the concepts learnt in senior 1 Physics, unit 12. This is important because some the concepts to be covered in this section were learnt.

### Learning Activity

#### Teaching guidelines for activity 10.5

- You have already grouped the learners before when they were doing activity 10.4, you may decide to maintain the groups for this activity or form new groups. Forming new group sometimes is important because it help learners to interact and share new ideas from different learners. It also promotes teamwork, cooperation among them.
- Ask the learners to do activity 10.5 given in the student's book page 286, that is, to find out the types of electrical cables and their standard sizes.
- With your guidance, lead them through the steps of doing the activity especially conducting a constructive research from Internet and reference books. Help those who may be having difficulties.
- Give them few minutes to discuss their findings and let the group secretaries write down the main points from the discussion. This will promote communication and leadership skills.
- Hold a whole class discussion on their findings. Use the opportunity to add any omissions and correct any error on their findings.



### Synthesis

Now ensure that learners have understood the following facts:

- Electrical cables comprise of three wires; live, neutral and earth wires.
- The wires can be distinguished using colour code, that is, brown for live wire, blue for neutral and green with yellow stripes for earth wire.
- The earth wire connects the metal case of an appliance to the ground and prevents it from becoming live if an electric fault develops.
- Sizing is the process of determining the appropriate size of the cables to be used for electrical purpose.
- Short circuit in a device, is when an electrical circuit of lower resistance than that of a normal circuit, typically resulting from the unintended contact of components and consequent accidental diversion of the current.
- Guide the learners through the discussion and examples given in the student book pages 285. Ensure that learners have understood the working in the examples. Help those who may have challenges in the calculation.

### Assessment

Ask learners to do questions 1-4 of exercise 10.2 in the student's book page 296. Ensure that you have marked their work and guided them appropriately.

**N/B:** See answers for the Exercise 10.2 at the end of this unit of the Teacher's guide.

**Answers to activity 10.5 student's book page 286.**

- In steps 1 and 2, three wires are live with brown/black colour, neutral with

blue colour and earth with yellow with green stripes.

### Lesson 4: Household wiring

#### Learning objective

The learner should be able to describe and carry out a simple surface wiring for a residential house using appropriate tools.

#### Teaching aid

- A chart showing domestic wiring system

#### Introduction to the lesson

In this unit, learners have already learnt electrical components and types of electrical cables. They have also learnt about electronic components in unit 15 of S2 Physics. By the method of question and answer or a small quiz, establish whether the learners mastered these concepts as you introduce this section. Use probing questions such as what electrical component that one require when he/she what to do house wiring? Which cables are used? What is the function of lightning arrestor? This is crucial because it will assist you to lay a good foundation for what the learners are about to learn in this section.

#### Learning Activity

#### Teaching guidelines for activity 10.6

- By now the learners should be able to organise themselves appropriately into different groups without your help whenever they are asked to do so. This does not mean you don't need to check and reorganise them where necessary. Therefore, organise them into appropriate groups depending



the availability of suggested learning materials and let them be ready to do activity 10.6. Working in groups will enhance personal and interpersonal management, teamwork and cooperation among learners.

- Ask the learners to do activity 10.6 in the student's book page 290, that is, to describe domestic wiring system. Ensure that all learners are involved. Those with disability of hands should be helped to walk around like others to identify main switch, sockets, meter box and circuit breaker within the school compound. Those with sight challenges should be helped to touch component such as sockets if they are reachable.
- Go around checking whether the learners are doing the right thing. Help those who may have difficult in any step of the activity.
- Give them few minutes to discuss their findings and let the group secretaries write down the main points from the discussion. This will promote communication and leadership skills.
- Hold a whole class discussion and ask the group secretaries to give the summarise report to the class. Use the opportunity to point out omissions and correct any error in each report presented.

#### **Synthesis**

Learners having done the activity, ensure they understand the following facts:

- Every circuit is connected in parallel with the power supply.
- There is no connection between the live and the neutral wires except through the electrical appliance.

Now lead them to understand the discussion given in the student's book pages 290-291 on household wiring.

#### **Teaching guidelines for activity 10.8**

- Organise the learners into appropriate groups depending on the suggested materials in the student's book, that is, computers with internet connection, reference books, a premise with lightning protection system. The teacher should always remember that it is good for learners to work in groups but those groups formed should reflect gender balance (in case of a class comprising of boys and girls) and different abilities (slow and gifted learners).
- Ask learners to do activity 10.8 in the student's book page 292, that is, to discuss how to install lightning arrestor and its importance.
- Guide the learners on how to conduct a research from Internet. Note that some learners may open different sites from the expected one; therefore it is important for the teacher to go around and guide them properly. This will promote research skill in learners.
- Allow them to discuss their observation from the activity. This will enable learners to realise the importance of teamwork and it will enhance communication skills in them.
- Go around to ensure that the main objective of this section (i.e. how to install the lightning arrestor and its importance) is realised by learners.
- Ask the learners to report their findings through their secretaries. Time may be insufficient, so let each group give a brief summary. This will promote communication and leadership skills in learners.

## Synthesis

Having discussed learner's finding from the activities, now lead the learners in the discussion to understand the following facts:

- Lightning protection system provide a specific path on which lightning can travel and it includes the following components; lightning rods, braided conductors, metallic bodies, ground rods and surge arrestor.
- Electric grounding cable should not be used in lightning system.

Now lead them to understand the discussion given in the student's book pages 292-293 on household wiring. Emphasize on the caution given in the student book page 294.

## Assessment

Ask learners to do questions 5 and 6 of exercise 10.2 given in the student's book page 296. Mark their work and guide them appropriately.

**Answers to activity 10.6 student's book page 290.**

- In steps 2 and 3. Refer to the discussion given in the student's book.

**Answers to activity 10.8 student's book pages 292.**

- In steps 2 and 3. Refer to the discussion given in the student's book.

## Lesson 5: Dangers of electricity

### Learning objective

The learner should be able to recall and explain the transmission of electricity and identify the dangers associated with electricity.

## Teaching aids

- Internet
- Reference books

## Introduction to the lesson

In unit 8 of this book, learners learnt about electrical power transmission. Through a small quiz establish whether the learners recall what they learnt. Hold a discussion on power generation and transmission with learners to ensure that they have mastered the concepts. This is important for this section because it will give learners a good foundation of understand dangers associated with electricity and how to safe while handling electricity.

## Learning Activity

### Teaching guidelines for activity 10.9

- You have already grouped the learners before when they were doing activity 10.8, you may decide to maintain the groups for this activity or form new groups. Forming new group sometimes is important because it help learners to interact and share new ideas from different learners. It also promotes teamwork, cooperation among them.
- Ensure that learners have sufficient materials suggested and computers are connected to the internet.
- Ask learners to do activity 10.9 provided in the student's book pages 294, that is, to describe the danger exposed by electricity and safety measures. Give a report.
- Guide them through the steps of the activity especially step 3 on conducting a comprehensive research from Internet and reference books.

- Go around checking whether the learners are doing the right thing. Help those who may have difficulty in any step of the activity. Learners with sight challenges can be given the cables by the others to feel them and then determine their thickness.
- With your guidance, allow them to discuss their findings for few minutes before asking the secretaries from each group to give a report to the whole class on their findings. This will promote leadership and communication skills in learners.
- Hold a class discussion on their findings and correct any errors (if any) in each report given. At this point, help learners to realise the importance of accepting other people's opinion whether they are right or wrong and in case they disagree, let them do so constructively. This will promote peace and harmony among the learners.

#### Synthesis

Having discussed learner's finding from the activities, now lead the learners in the discussion to understand the following facts

- Dangers of Electricity include a variety of hazards that include Electric Shock, Psychological Damage, Physical Burns, Neurological Damage and Ventricular fibrillation resulting in death.
- Any form of energy, when not properly controlled or harnessed, can result in serious danger to those who use it. The risks inherent with electric power can generally be divided into two categories: direct and indirect. The direct danger is the damage that the power itself can do to the human

body, such as stoppage of breathing or regular heartbeats, or burns. The indirect dangers of electricity include the damages that can result to the human body as a result of something caused by electric shock, such as a fall, an explosion, or a fire.

- Electricity at any voltage can be dangerous and should always be approached with caution. An electric shock can occur upon contact of a human or animal body with any source of voltage high enough to cause sufficient current flow through the muscles or nerves. The minimum current a human can feel is thought to be about 1 milliampere (mA). As little as 80 milliampere, can seize the heart muscle. The current may cause tissue damage or heart fibrillation if it is sufficiently high. A fatal electric shock is referred to as electrocution.
- Guide them through the discussion given in the student's book pages 294-295 to emphasize the facts learnt.

#### Assessment

Ask learners to do question 7 of unit test 10 in the student's book page 297. Mark learner's work and guide them appropriately. This part will promote critical thinking skills among the learners.

#### Answers to activity 10.9 student's book page 295-296.

- In step 2, refer too the discussion given in the student's book page 294-295.

#### Summary of unit

- At random, ask different learners to lead others in brief discussion of different concepts highlighted in the unit summary given the student's

book pages 296. By asking them probing questions, help them recall the concepts.

- Ask learners to go back to the unit focus activity given on pages 278. Let them now give the correct solutions to the questions asked therein. Since the questions have been answered at one instance within the unit, help them to understand how to give correct answers.

#### **Additional information to the teacher**

It is important the teacher to know the following facts:

- Light lamps are the removable and replaceable part of a light system, which converts electrical energy into electromagnetic radiation. While lamps have traditionally been rated and marketed primarily in terms of their power consumption, expressed in watts. Proliferation of lighting technology beyond the incandescent light bulb has eliminated the correspondence of wattage to the amount of light produced. For example, a 60 W incandescent light bulb produces about the same amount of light as a 13 W compact fluorescent lamp. Each of these technologies has a different efficacy in converting electrical energy to visible light. Visible light output is typically measured in lumens. This unit only quantifies the visible radiation, and excludes invisible infrared and ultraviolet light. A wax candle produces on the close order of 13 lumens, a 60-watt incandescent lamp makes around 700 lumens, and a 15-watt compact fluorescent lamp produces about 800 lumens, but actual output varies by specific design. Rating and

marketing emphasis is shifting away from wattage and towards lumen output, to give the purchaser a directly applicable basis upon which to select a lamp.

- Cables are mainly designed as per requirement. Power cables are mainly used for power transmission and distribution purpose. It is an assembly of one or more individually insulated electrical conductors, usually held together with an overall sheath. The assembly is used for transmission and distribution of electrical power. Electrical power cables may be installed as permanent wiring within buildings, buried in the ground and run overhead or exposed. Flexible power cables are used for portable devices, mobile tools and machinery. These are designed and manufactured as per voltage, current to be carried, operating maximum temperature and purpose of applications desired by customer. For mining, we give extra mechanical strength to cable with double armouring. For wind power plant customers generally require flexible and UV protected cable with mechanical tough sheath so we design as per their requirement.

#### **Lesson 6: Unit assessment**

Ask learners to do unit test 10 provided in the student's book pages 297-298, individually. Mark their work and hold a discussion on their results. This is important because it will help you as teacher to assess the communication skills when discussing the results and whether the learners have attained the objective of the unit. It will also help to promote critical thinking among them.

### Remedial activities/questions for slow learners

- Define the following terms:
  - Fuse
  - Circuit breaker
  - Electric lamp
- Name two electric components used for household wiring.
- List two dangers of associated with electricity
- Name three wires found in electrical cable. What are their colour code?

### Answers to activity/questions for slow learner

- A fuse is a thin piece of wire of low melting point. It melt or blow off when a large current flow through it.
  - Circuit breaker is automated electrical switch designed to protect an electric circuit from damage by either over heating, overloading or short circuit.
  - Electric lamp is a light electrical device used in different circuit for lighting and indication.
- electrical cables, switch
- ,
  - Electrical shock
  - Electrical fire due to overheating
- live ( brown/black ) , neutral (blue) and earth (yellow with green stripes)

### Extended activities/ questions for gifted learners

- Explain the process of installing lightning arrestor in your house.
- Imagine you are electrician, describe how you can do electrical wiring in you class.

- Discuss five dangers associated with electricity and suggested how they can be avoided

### Answers to the extended activities/ questions for gifted learners

- Refer to the discussion given in the student's book for explanation to questions 1-3. Mark the student's work and guide them appropriately.

### Answers to exercises and unit test 10

#### Exercise 10.1

(Learner's book pages 285-286)

1.

Name	Symbol
Bulb/lamp	
Battery	
Fuse	
Transformer	
Capacitor	
Dc voltage	
Ground	
Circuit breaker	

- When tungsten metal is heated it glows producing light (becomes white hot) and has a high melting point.
- A fuse is a short piece of wire of low melting point. This wire melts as soon as the current through it exceeds its rated value.
- 8A
- A circuit breaker is an automatically operated switch designed to protect an electrical circuit from damage caused by either over flow or current, overload or short circuit.



6. A circuit breaker is a switch that automatically turns off when there is current overload and it can turn on when current normalizes but a fuse is a wire that melts when there is an overload and needs to be replaced.

### Exercise 10.2

(Learner's book pages 296)

1. Brown for live, blue for neutral and green with yellow strips for earth
2. A fuse is a thin wire with a low melting point that melts when there is current overload to protect an electric device.
3. Refer to student book page 288.
4. Refer to student's book pages 289.
5. When an electric fault occurs the earth wire connects the current to the ground and prevents the person touching a metal connected to the circuit from being electrocuted.
6. Refer to discussion given in the students book pages 290-291.

### Unit Test 10

(Learner's book page 297-298)

1. (a) Switch, electrical cables, electrical lamp, fuse, circuit breaker  
(b) Refer to the discussion in the student's book for the diagram.  
(c) Refer to the discussion given in the student's book for explanation
2. It keep the appliances safe in case of electrical faults
3. Refer to the student book page 287
4. (a) Incandescent, LED and gas-discharge lamps  
(b) xenon, neon

- (c) it suppress the evaporation of the tungsten filament thus increasing its life time.
- (d) because it has high melting point
5. (a) to interrupt the large current from flowing  
(b) To cut off large current flowing by melting or blowing off
6. Refer to the discussion given in the student's book
7. Refer to the discussion given in the student's book .
8. Refer to the discussion given in students book.
9. Brown for live, blue for neutral and green with yellow strips for earth.
10. (a) L – Live wire connection  
N – Neutral  
E – Earthing.  
Brown for live, blue for Neutral and green with yellow strips for earthing.  
(b) – Use the correct application in a socket to avoid overload  
– Always replace broken plugs and naked wires  
– Use right size of circuit breakers and fuses to avoid overloading

11.  $P = 750 \text{ W}$

$V = 240 \text{ V}$

$F = ?$

$P = IV$

$$\frac{750}{240} = \frac{240 I}{240}$$

$3.125\text{A} = I$

A fuse with a 3A ratio is not suitable



12. Maximum number of 75W bulbs is 9 bulbs.
13. (a) 0.5A  
(b) Yes  
(c) 12W  
(d) If one gets a fault, all the other three can remain working rather than if it was a series circuit, all would stop working.
- 14.

Switch A	Switch B	Lamp on/off
1	3	OFF
1	2	ON
4	3	ON
4	2	OFF

## Basic Alternating Currents Circuits

Students book page 299-330 (3 Periods)

### Key Unit Competence

By the end of this unit, the learner should be able to design and analyse simple alternating current circuits.

### Prerequisite to this unit

For learners to acquire the knowledge, skills, altitude and values envisaged in this unit with ease, they need to have acquired the following:

- Knowledge on simple electric circuit components learnt in S1 unit 12 and skills on constructing a simple electric circuit with resistors in series and parallel, ammeter and voltmeter learnt in S2 unit 13. The teachers should establish through question and answer method or through a small quiz whether the learners remember the concepts learnt. This is important since learners will be expected to apply this knowledge at one point within the unit.
- Knowledge on capacitors, inductors learnt in S2 unit 15. Through question and answer method, establish whether the learners can tell what a capacitor and an inductor are, their symbols and functions. This is very crucial to the learners since they will encounter these components once again in this unit. Therefore, the teacher should establish and ensure learners are able to recall and master the concepts as an introduction to these unit.
- Knowledge on alternative current learnt in unit 7 of this book. Through question and answer method, establish whether the student recall what they learnt. This is important because some of the concepts to be learnt in this unit require the learner to apply the concepts learnt in unit 7.

### Cross-cutting issues addressed

The specific crosscutting issues to be addressed in the unit are:

- **Standardization culture-** Since the unit involves use of components such as galvanometer, ammeters, and voltmeters the teacher should use the opportunity every time the learners are handling them to sensitize them the importance of using standard apparatus.
- **Inclusive education:** The unit has wide range of activities and exercises that encourages inclusiveness of every learner. The teacher should ensure that all learners (slow, gifted, disables) are involved actively in doing all the activities in the unit.

### Generic competences

The specific generic competences to be addressed in this unit include:

- **ICT:** This competence will be achieved when the teacher will involve learners in conducting research from Internet such as Activity 11.7 on connection of inductor to a.c source.

- **Critical thinking:** This competence will be achieved when the teacher will involve learners in doing activities especially the unit focus activity and exercises such as 11.2 that require the learner to explain and describe the particular concept.
- **Problem solving:** This competence will be achieved when the teacher involves learners in activities and exercises to find a solution, especially calculations in the unit, for example exercise 11.2.

### Vocabulary /Keywords

In the course of learning the concepts in this unit, the learners will discover the meaning of the following new words:

- Impedance
- Capacitance
- Capacitive reactance
- Inductance
- Independence, Z
- Resonance frequency

Guide the learners to understand the meanings of these words and construct and speak out the Physics statement involving them in order to master their meaning and usage.

### Guide on the problem statement

In order to motivate learners and make them eager, attentive and active when learning the concepts in this unit, facilitate them to do the unit focus activity (Try this) outlined in the learner's book page 300.

The activity entails designing of electric circuit using the given electrical components.

### Teaching aids required

Capacitor, inductor and resistor

### Teaching guidelines for unit focus

- Organize the learners into convenient groups, depending on the availability of reference materials and or resource. Ensure that each group has access to the suggested materials. Working in groups will promote *cooperation, personal and interpersonal management* among other competence in learners.
- Ask them to do unit focus activity given in the student's book pages 300.
- Guide them through the activity without giving answers to the questions and allow them to answer the asked questions in the unit focus activity.
- Allow learners to hold a discussion in their groups as they attempt to respond to all questions asked in the activity. This will promote *cooperation, communication skills* and *leadership skills* among other competences in the learners.
- Ask them to present their findings to the rest of the class through a class discussion, as you gauge the accuracy of the names of the components and their sketch.
- It is most likely that most learners will come up with different names, explanation, and sketching that are inaccurate. At this point, show the learners the importance of accepting different opinions given by different learners whether right or wrong. This help to promote *peace value* among the learners.

- Appreciate the groups that may have identified the electric components correctly and their sketch. Use this opportunity to let the whole class know that by actively participating in all the lessons planned for this unit, they will be able to design an electric circuit using the electric components named and any other.

### Attention to special needs

In order to involve all learners in the learning process, you must know all your learners especially those with special need in your class.

- The unit comprises of numerous activities, you should involve the special need learners in these activities. For example, those activities that

require use of hands to design electric circuit they can be asked to hold the components as the other do it. They can also be asked to observe and give their suggestion. Remember *disability is not inability!* Encourage the other student to appreciate suggestions of every student whether right or wrong.

- Some of the questions in the exercises can be given to gifted learners. Prepare additional more challenging questions for them learners. (See remedial questions for gifted learners at the end of this Teacher's guide unit)
- For slow learners, organise remedial lessons for them. Guide them through the activities and exercise once again and more slowly to help them understand.

### List of lessons

Lesson No.	Lesson title	Number of periods
1	Standard symbols used in electric circuit & functions	2
2	Differences between alternating current (a.c) and direct current (d.c)	2
3.	The circuit for analysing resistors, capacitors and inductors in a.c circuit	1
4.	A single resistor connected in series to an a.c supply	2
5.	A single capacitor connected in series to an a.c source	2
6.	A single inductor connected in series to an a.c source	2
7.	Resistor, inductor and capacitor (RLC) in series to an a.c power supply.	1
8.	Unit Assessment	1
	Total	13

**N/B:** Lesson 1 is provided more time to factor in time for unit focus activity.

#### Lesson 1: Standard symbols used in electrical circuit and function.

#### Learning objective

By the end of this unit the learner should be able to identify circuit symbols representing electrical component.

#### Teaching aids

- Cell
- Bulb
- Switch
- Capacitor
- Inductor

- A.C. source
- D.C source
- Connecting wires

### **Introduction to the lesson**

Review with the students the electrical symbols that were covered in S1 and S2 through questions and answers method. Link the introduction to the lesson of the day.

### **Learning Activity**

#### **Teaching guidelines for activity 11.1**

- Organise learners into appropriate groups, that is, if the class is mixed, ensure you have the gender balance (i.e., equally number of boys and girls if possible) and also they are of different abilities. This will help learners to appreciate the factor that all students (whether boys or girls) should be given equal opportunity to learn and also to promote cooperation among them.
- Learners to do activity 11.1 given in the student's book page 301.
- With your guidance, lead them through to describe the function of electrical components given to them and allow them to do the activity by their own.
- Give them few minutes to discuss their findings and let the group secretaries write down the main points from the discussion. This will promote communication and leadership skills.

- Hold a whole class discussion and ask the group secretaries to give the summarised report to the class. Use the opportunity to point out omissions and correct any error in each report presented.

#### **Synthesis**

Now hold a discussion with learners on electrical components given in table 11.1 in the student's book page 301-302.

Ensure that the learners have mastered the name, symbol and function of each component.

a.c has these advantages.

- Easily available at a wall socket near you.
- Easily stepped up and down for long transmission with fairly low loss
- Easy to generate with A.C Generator/ motor from rotary sources (e.g. turbines)
- Easy to make powerful, reliable motors (induction type)
- Frequency reference for clocks and other devices needing frequency reference
- Easily rectified to D.C if needed.

#### **Assesment.**

Ask the learners to do question 1 and 2, exercise 11.1 in students book page 308.

#### **Answers to Activity 11.1**

Refer to the discussion in the students book page 301-302.

	Alternating Current	Direct Current
Amount of energy that can be carried	Safe to transfer over longer city distances and can provide more power	Voltage of d.c cannot travel very far until it begins to lose energy
Cause of the direction of flow of electrons	Rotating magnet along the wire	Steady magnetism along the wire
Frequency	The frequency of alternating current is 50Hz or 60Hz depending upon the country	The frequency of direct current is zero
Direction	It reverses its direction while flowing in a circuit	It flows in one direction in the circuit
Current	It is the current of magnitude varying with time	It is the current of constant magnitude
Flow of Electrons	Electrons keep switching directions – forward and backward	Electrons move steadily in one direction or 'forward'.
Obtained from	a.c Generator and mains	Cell or battery
Passive parameters	Impedance	Resistance only

## Lesson 2: Differences between alternating current (a.c) and direct current (d.c)

### Learning objective

At the end of this lesson the learners should be able to differentiate between alternating current (a.c) and direct current (d.c)

### Teaching aids

- Dry cells
- Galvanometer
- Bicycle dynamo

### Introduction to the lesson

In Unit 7, learners learnt about the root-mean-square and a.c generator. Through questions and answer help the student to remember  $V_{ac} = V_{peak} \sin \omega t$ . This is important because the section will require application of the concept learnt.

### Learning Activity

#### Teaching guidelines for activity 11.2

- You have already grouped the learners before when they were doing activity 11.1, you may decide to maintain the groups for this activity or form new groups. Forming new

group sometimes is important because it help learners to interact and share new ideas from different learners. It also promotes teamwork, cooperation among them.

- Ask learners to do activity 11.2 provided in the student's book pages 302-303, that is, to differentiate between d.c and a.c sources.
- Go around checking whether the learners are doing the right thing. Help those who may have difficulty in the electric circuit connection.

### Synthesis

Guide the learners through the discussion given in students book page 303 to 304.

Having done the activity and discussed their finding, emphasise the following facts:

- The oscillation shape of a.c supply follows that of a sine wave, that is
 
$$V_{ac} = V_{peak} \sin \omega t$$
- For d.c, voltage is the same as that across the resistor, that is
 
$$V_{dc} = VR$$



- When working with a.c voltage and current, we use the r.m.s

Guide the learners through the discussion given in the student's book as you conclude this section.

#### Assessment

- Ask the students to use Internet to add more differences to the list in the student book.
- Ask learners to do questions 2 of unit test paper 11 given in the learner's book Page 328.

#### Answers to activity 11.2

In steps 1 and 2, the pointer in the galvanometer deflects.

#### Lesson 3. The circuit for analysing resistors, capacitors and inductors in an a.c circuits

#### Learning objective

By the end of this lesson the learners should be able to make a connection involving a capacitor, resistor and an inductor.

#### Teaching aids

- Low frequency generator
- d.c voltmeter (centre-zero)
- d.c armeter (miliameter and centre zero)
- Inductor
- Stop watch
- Carbon resistor
- Trodile clips

#### Introduction to the lesson

Learners have already covered lessons on capacitors, inductors and resistors. They should be able to differentiate as well as state their functions in a circuit. The circuit they are going to prepare will be used

through out the topic thus it is important for all learners to get a good understanding of this activity.

#### Learning activities

#### Teaching guidelines for activity 11.3

- Organise learners in pairs to do activity 11.3 in student's book page 304.
- Its important to note that the circuit will be used through out the topic thus it is very important for every learner to master it.
- Ensure that the learners are all participating in the activity.

#### Synthesis

After the learners have completed the activity remind them to master the circuit as it is very important for this topic.

#### Assessment

Ask the learners to do question 3 of exercise 11.1 in the students book page 309.

#### Lesson 4. A single resistor connected in series to an a.c supply

#### Learning objective

The student should be able to design an electric circuit consisting of a resistor in an a.c voltage

#### Teaching aids

- A resistor (carbon resistor)
- Connecting wires
- A.C. Ammeter
- D.C voltmeter
- A.C source
- Low SOH<sub>3</sub> frequency generator
- Bulb

## Introduction to the lesson

Review the operation (working) of a.c generator where the current and therefore the voltage direction follow a sine wave.

## Learning activities

### Teaching guidelines for activity 11.4 and 11.5

- Organise learners into convenient groups depending on the availability of learning materials. Remember the groups formed should observe different abilities and gender balance in case of a mixed class.
- Once you have been satisfied by the group composition, ask learners to do activity 11.4 given in the learner's book page 305, that is, to analyse the behavior of a single resistor connected to an a.c source.
- Go around the class to ensure that learners are doing the correct thing. Guide those with challenges on drawing and designing an a.c circuit.
- Allow learners to hold a discussion in their groups on their drawing and the design of the circuits. This will promote cooperation, communication skills and leadership skills among other competences in learners.
- Now set up the circuit as shown in fig. 11.3. Use the brightness as a measure of resistance of the circuit. Show the students how the frequency of a source can be changed i.e use of frequency generator.
- After the learners have done activity 11.4, let them do activity 11.5 that is to show the relationship between resistance and frequency.

## Synthesis

Analyse the results of activity 11.5. The frequency does not affect the resistive nature of resistance i.e impedance is a constant.

Guide the learners through the discussion given in the students book after each activity. Help them understand the facts outlined in the discussions.

## Assessment

Ask the students to work in their study group and discuss examples 11.1 and 11.2 in students book page 308. Ask to do question 3 of Exercise 11.1.

## Answers to activities 11.4 and 11.5

Refer to the discussion in the students book and guide them appropriately.

## Lesson 5: A single Capacitor connected in series to a.c source

### Learning objective

At the end of this lesson the learner should be able to describe the function of a capacitor in an a.c circuit.

### Teaching aids

- Capacitors
- Crocodile clips
- Connecting wires

### Introduction to the lesson

Since the students are meeting the capacitors for the first time, use activity 11.6 to explain through question and answer method. Some common terms in capacitors e.g. capacitance, charging and discharging, Farad as the unit of capacitance,  $Q = CV$ .

## Learning activities

### Teaching guideline for activity 11.6

- Using the groups formed in activity 11.5, ask learners to do activity 11.6 and 11.7.
- Guide them through the activity.
- Hold a discussion on their findings from the activity.

### Synthesis

Design an electrical circuit involving a capacitor connects to an a.c circuit. Let the student perform activity 11.6 on page 310. After the activity discuss with learners what a capacitor is and how it is connected in a circuit. Guide them through discussion in the learners book page 513.

### Assessment

Ask the student to go through Example 11.3 and 11.4 in the students book page 313. Select some question in Exercise 11.2 and ask the students to discuss them in their study groups. Visit the groups and attend to their problems.

Answers to activity 11.6 refer to the discussion in the students book page 310-313 and guide them appropriately.

## Lesson 6: A single inductor connected in series to a.c source.

### Learning objective

By the end of this unit the learner should be able to identify circuit symbols representing electrical components in an a.c circuit involving a single inductor.

### Teaching aids

- Inductor
- Connecting wires
- Crocodile clips

- Ammeter
- Voltmeters
- Low a.c frequency generators

### Introduction to the lesson

Use a hallow tube and a ferromagnetic former to explain how to make an inductor.

### Learning activities

### Teaching guideline for activity 11.7

- Using the groups formed in activity 11.6, ask learners to do activity 11.7 in the student's book page 316.
- Guide them through the activity.
- Hold a discussion on their findings from the activity.
- Use this activity to discuss with the students what an inductor is.
- Design an electrical circuit involving an inductor in an a.c circuit.

### Synthesis

Through question and answer method explain the equation  $X_L = 2\pi fL$ . The graph of  $X_L$  against

### Assessment

Use the equation  $X_L = 2\pi fL$  and ask the students to sketch a graph of  $X_L$  against  $f$ , what is the slope representing.

### Answers to activities 11.7

Refer to the discussion in the students book and guide the learners appropriately.

### Teaching guidelines to activity 11.8

- Using the groups that learners formed when doing activity 11.4 let the learners do activity 11.8 you may reorganise the learners to ensure maximum participation by learners in the activity.

- Let them do activity 11.8 that is to investigate relationship between inductive reactance and frequency.
- Hold a discussion with the learners on their findings and guide them appropriately.

#### Synthesis

Guide the learners to understand the facts as outlined in the students book page 317-318.

Guide them through example 11.5 and 11.6 in students book page 318-319.

#### Assessment

Let the learners do exercise 11.3 in the students book page 320.

#### Answers to activities 11.8

Refer to the discussion in the learners book and guide them accordingly.

### Lesson 7. Resistance, capacitance and inductance in series with an a.c power (RLC)

#### Learning activity

By the end of this lesson the learner should be able to use the electrical symbols to design an electrical circuit involving resistors, capacitor and inductor in series with an a.c source.

#### Teaching aids

- inductor
- low range (mv) centre zero
- ammeter
- low frequency generator
- low range (mv) centre-zero voltmeter
- variable capacitor
- milliammeter
- carbon resistor
- capacitor

- A.C source
- Connecting wires

#### Introduction to the lesson

Learners having covered lessons on inductors, capacitors and resistors, at this point, it is good to remind them what they learnt as it will form a basis of what they will cover in this lesson.

#### Learning activities

#### Teaching guideline for activities 11.9 and 11.10 student's book pages 312 and 324

In groups, ask learners to perform activities 11.9 and 11.10 provided in the students book.

Guide them through the activities and assist the learners who may be having difficulties.

#### Synthesis

- Using activity 11.8 to hold a discussion with learners on the equation
- $Z = \sqrt{(R^2) + (V_L - X_C)^2}$
- Ask the students to sketch on the same axis a graph of impedance against frequency for inductor, capacitor and resistor in series
- Use activity 11.9 to arrive at resonating frequency,  $f_r = \frac{\text{Synthesis}}{X_L}$
- Take them through examples 11.7 and 11.8 given in the students book page 325-327, and assist the learners who may be having difficulties.

#### Assessment

Ask the students to attempt Exercise 11.4 as a supervised practice.

#### Answers to activities 11.9 and 11.10

Refer to the discussion given under each activity and guide them appropriately.

## Summary of unit

- At random, ask different learners to lead others in brief discussion of different concepts highlighted in the unit summary given the student's book page 328. By asking them probing questions, help them recall the concepts.
- Ask learners to go back to the unit force activity given on pages 300. Let them now give the correct solutions to the questions asked therein. Since the questions have been answered at one instance within the unit, help them to understand how to give correct answers.

## Additional information

The voltage across an inductor "leads" the current because of the Lenz's law. Therefore, the phasor representing the current and voltage would be given as in. Again, the phasors are vectors rotating in counter-clockwise direction at a frequency (you can see that the voltage leads the current). Phasors can be used to analyse RC, RL, LC, and RLC circuits.

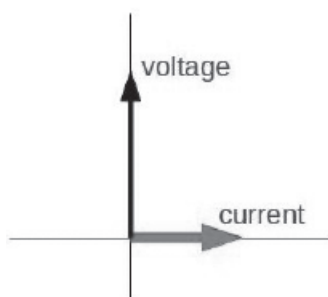

## Lesson 8: Unit assessment

Ask learners to do unit test 11 provided in the student's book page 328-330, individually. Mark their work and hold

a discussion on their results. This is important because it will help you as teacher to assess the *communication skills* when discussing the results and whether the learners have attained the objective of the unit. It will also help to promote *critical thinking* among them.

## Remedial questions for slow learners

1. Define the terms capacitance
2. What is the SI unit of capacitance?
3. Design a simple circuit with, bulb, cell, connecting wire, resistor and switch

## Answers to remedial questions for slow learners

Refer to the student's book and mark the learner's work.

## Extended question for gifted learners.

1. Describe how you can design an electric circuit with inductor, source of power, resistor, capacitor, connecting wires and switch.
2. Discuss two difference between a.c and d.c power source.
3. Discuss how a capacitor is connected to a.c power source

## Answers to extended questions for gifted learners

Mark the student's work and guide them appropriately. You may refer to the discussion given in the student's book or use Internet and reference books.

## Answers to numerical questions of exercises and unit test 11

### Exercise 11.1

(Learner's book pages 308-310)

- Resistance (R) is the opposition to the flow of direct current while impedance (Z) is the opposition to the flow of alternating current.
- 

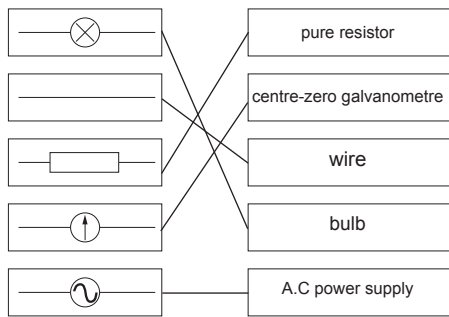

- Refer to the learner's book
- (a) Z (b) Y (c) X
- (a)  $I = I_0 \sin \omega t$   
 $I$  = Induced current in the coil at anytime  $t$ (s)  
 $I_0$  = Peak value of current  
 $\omega$  = angular velocity of the coil  
 $t$  = time in seconds

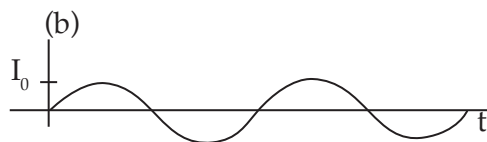

- (c)  $V = V_0 \sin \omega t$
- $I_0 = 6\sqrt{2}$  A 7. (a) 282.84 mA
  - (a) 25 Hz (b) 1.4142V (c) 0 (d) 0.5 W

### Exercise 11.2

(Learner's book pages 314-315)

- B 2. D 3. A 4. C 5. B
- A 7. A 8. A 9. C
- Refer to learners work on page 310 - 311
- (a)  $2.82 \mu\text{F}$  (b) 3.55 A

### Exercise 11.3

(Learners book page 320)

- A 2. C 3. B 4. 10 mA
- (a) 0.019A (b) 0.0064 A

### Exercise 11.4

(Learners book page 327)

- A
- (a) 0.0054 A (b)  $I_R = 21.6$  V  
 $V_C = 67.5$  V
- (a) 1123 rads/s (b) 6.6 A  
(c)  $X_C = 8.0 \times 10^{-3}$ ,  $X_L = 1.6$  K $\Omega$ ,  
 $Z = 1.475$  k $\Omega$
- $Z = 15.636$  K $\Omega$ ,  $V = 1.105$  KV
- (a)  $Z = 300 \Omega$  (b)  $L = 0.192$

### Unit test 11

(Learners book page 328-330)

- A 2. B 3. C 4. B
- $1.2 \times 10^{-6}$  H
- (a)  $8.54 \Omega$  (b) 12.9 A (c) 18.2 A  
(d) 1.32 KW
- (a)  $8.8 \times 10^{-5}$  F (b) 27.5 A  
(c)  $4.33 \times 10^{-3}$



**Key Unit Competence**

By the end of this unit, the learner should be able to explain refraction of light phenomenon.

**Prerequisites of this unit**

The teacher through question and answer method should review what was covered in S1 on rectilinear propagation of light especially on the following areas

- Ray and beams
- Light travel in a straight line
- Reflection of light at plane mirror surface

The mathematical knowledge on sine of angles and alternating, correspond and opposite angle. It is a good idea for the teacher to encourage the students to have a geometrical mathematical set.

**Cross cutting issues to be addressed**

The teacher should address the following cross cutting issues

- Gender:
  - i. Form groups that have both sexes.
  - ii. Make sure you distribute your question to both sexes
  - iii. Avoid negative comments that will be misinterpreted by either sex for example glasses are common to ladies for beauty reasons.
- Peace and values education – lenses should not be used to burn others by

focusing rays of sun on bodies of other unsuspecting students.

- Financial education- The unit deal with instruments such as microscopes which are costly to replace once it has been broken done. Learners are cautioned to handle them with a lot of care.

**Generic competences**

- The unit comprises of activities and exercises that boost critical thinking and problem solving skills.
- The unit encourages creativity and innovation e.g. use of water in conical flask as a lens.
- The unit develops life skills in learners by allowing them to show practically how to correct the defects in the eye.
- The unit encourages co- operation as learners work in groups. Allow the students to discuss their finding to improve in communication skills.

**Vocabulary or key words or concepts**

The teacher should use simple words e.g. bending, change of direction for words like refraction ; the ability of media to bend the rays for refractive index. Other vocabulary word includes, media, optical fiber convex, concave, and chromatic and spherical aberration.

Encourage students to use Internet to get explanation on vocabulary or keyword or concept.

The word phenomenon will sound complex term to the student. Give them as an assignment using the Internet to research on it. Allow time for the discussion.

### **Guidance on the problem statement.**

- For learners to have a general idea of what they will be learning in the activity, the teachers should allow them to do the unit focus activity on their own. The teacher will only be required to provide learners with the suggested learning materials.
- Organise learners into appropriate pairs or groups and provide them with the materials suggested (microscope, optical fibre) . Once you have given them the materials (either in pairs or groups depending on the availability of materials) ask the learners to do the unit focus activity given in student's book pages 337-338.
- At this point, bring to the attention of learners the need of handling a microscope with a lot of care (it is costly to replace once damage)
- Allow learners to hold a discussion in their groups as they attempt to respond to all questions asked in the activity. This will promote cooperation, communication skills and leadership skills among other competences in the learners.
- Use their feedback to guide them in such away that leads to the correct responses to the questions asked in the activity. The teacher can use probing questions. By doing that, you will be promoting the critical thinking of your learners.
- It is most likely that most learners will come up with different observation,

explanation, and description that are inaccurate. At this point, show the learners the importance of accepting different opinions given by different learners whether right or wrong. This help to promote peace and harmony among the learners.

- Use their feedback to trigger their curiosity in order for them to see the need of learn more from the unit.
- Encourage those learners whom may have not responded correctly especially the slow learners that the correct answers will be obtained in the process of learning the unit so that by the end of it, they can be able to respond correctly to all questions asked in the unit focus activity.

### **Attention to special educational needs**

- This unit involves the use of the eyes to study refraction of light. Take care of the student with sight problem. Give them more attention during and after the various activities suggested in the student book. Act innovatively depending on the sight problem concerned.
- Some of the questions in the exercises can be given to gifted learners. Prepare additional more challenging questions for them learners. (See remedial questions for gifted learners at the end of this Teacher's guide unit)
- For slow learners, organise remedial lessons for them. Guide them through the activities and exercise once again and more slowly to help them understand

## List of lessons

Lesson no	Lesson title	Number of periods
1	Phenomena of refraction of light	2
		2
		1
2	Refraction of light through a prism	2
		2
3	Refraction of light through a thin lens	2
		1
		2
4	Unit assessment	1
	Total	15

### Lesson 1: Phenomena of refraction of light

#### Learning objective

The learner should to explain phenomenon of refraction of light.

#### Teaching aids

- Plastic ruler
- Water in a transparent container
- Geometrical set
- Rectangular glass block
- Ray box

#### Introduction to the lesson

In Senior 1 unit 13, learners learnt about rectilinear propagation of light. Using question and answer methods, establish whether the learners recall concepts learnt such as, nature of light, and rectilinear propagation of light, characteristic of images formed by plane mirror among others. This is important because most of the concepts to be learned in this part of the unit require some applications of the concepts already learnt.

Use activity 12.1 to show the phenomenon of refraction of light as this is a commonly experienced phenomenon.

You may also show refraction by rainbow, shining in desert, shadow and deep along the practical observation depending on the locality of the school and the experiences of your students. This will develop curiosity in learners to learn more from the unit and also make the unit interesting and lively.

#### Learning activities

#### Teaching guidelines for activities 12.1 and 12.2

- Organise learner into pairs to do activity 12.1 in the learner's book page 334.
- Let them observe how the ruler appears while in the water.
- Allow them to discuss their observation.
- Let learners do activity 12.2 in students book page 335.
- Activity 12.2 show how light rays travel using a rectangular glass block. Care should be taken to avoid any confusion that may be created by activities 12.1 & 12.2. Let the student appreciate that refraction can occur between any two or more transparent media. It is only the direction of the light rays that matters. In case of activity 12.1, the light moves from water to air (where your eye is) while in activity 12.2, light moves from air to the glass block. It would be necessary to explain in activity 12.1 using rays. Use activity 12.2 to explain terms associated with refraction of light.

## Synthesis

Use the concept of optical density to justify refraction of light in transparent media. Light is a form of wave energy. Diagrams in figure 12.6 demonstrates light is deviated away, towards and on the normal. Emphasis that refraction occurs at a boundary (interface)

## Assessment

Give exercise 12.1 as an take away assignment allow the students to exchange their books and guide them on how to mark the assignment this promotes honesty and trust among the students.

## Answers to activities 12.1 and 12.2 student's book page 334-335

Refer to the discussion given in the student's book after every activity

## Law of refraction

### Learning objective

The students should be able to state the law of refraction.

### Teaching aids

- Mathematical set
- Four pins
- Softboard
- A glass block
- Paper protector (obtained by photocopy a real protractor)
- A ray box
- Semi- dark room
- White plain papers

### Introduction to the lesson

The lesson may be introduced by showing how you can obtain a sine and an angle. This concept was learnt in mathematics.

Demonstrate how to setup the apparatus and how to get the values of  $i$  and  $r$  from the setup. Then allow the groups to perform the activity 12.3 in order to obtain other values of  $i$  and  $r$ .

## Learning activities

### Teaching guidelines for activities 12.3 and 12.4

- Demonstrate how to setup the apparatus and how to get the values of  $i$  and  $r$  from the setup. Then allow the groups to perform the activity 12.3 in orders to obtain other values of  $i$  and  $r$ .
- Now, still maintaining the same groups used in activity 12.2 or you may consider reorganise them, ask learners to do activity 12.3 in the student's book pages 337-338. It is important learners to work in groups but appropriate one (i.e., gender sensitive and of different abilities). The groups should be as small as possible in terms of membership to reduce cases of some members not participating. This will promote leadership skills, cooperation and teamwork among the learners.
- Let the student perform activity 12.3 and complete table 12.1. Show that incident ray refracted and normal at the point of incidence all lie on the same plane. You may use a white plain paper to show the planes, you can also use activity 12.4 to arrive at the same conclusion. This experiment is popular for schools without ray boxes and electricity. However, it is difficult for students. You should first of all deal with the concept of "No parallax method."

### Synthesis

Using the data and observation from activity 12.3 guide the students on how to arrive at laws of refraction. Analyse the graph in fig 12:10 to emphasis as Snell's law.

### Assignment

Ask the students to use Internet to show the plane stated in the laws of refraction.

### Answers to activities 12.3 and 12.4 student's book

Refer to the discussion given in the student's book after every activity.

### Refractive index

#### Learning objective

At the end of this lesson the student should be able to

- (i) define refraction index
- (ii) determining refractive index of a material using different methods
- (iii) solve problem on refraction

#### Teaching aids

- Graph paper
- Geometrical set

#### Introduction to the lesson

Review on graph drawing particularly of a straight line. Revision on how to choose a suitable scale in graph drawing. Involves you a student in this introduction as much as possible as this is the beginning of intense graph drawing even for the examination.

#### Learning activities

#### Teaching guidelines for activities 12.5,12.6 and 12.7

- Hold a class discussion on the refractive index given in the student's book pages 341-342.
- Discuss table 12.2 and examples 12.1-12.5 in the student's book page 342-344.
- By now the learners should be able to organise themselves appropriately into different groups without your help whenever they are asked to do so. This does not mean you don't need to check and reorganise them where necessary. Therefore, organise them into appropriate groups depending the availability of suggested learning materials and let them be ready to do activities 12.5-12.7. Working in groups will enhance personal and interpersonal management, teamwork and cooperation among learners.
- Ask them to do activity 12.5 to 12.7 in the student's book.
- Guide the learners through the discussion given after each activity before they do the next one. Each activity highlights different concepts thus it is necessary for each learner to participate in all activities.
- Ask the student to draw /plot a graph of  $\sin i$  against  $\sin r$  obtained in activities 12.4.
- Activity 12.5 may be used to demonstrate the reversibility of light.
- Let the students perform activity 12.6 and 12.7 used to determine the refractive index of a substance using real and apparent depth. Guide them thought the activity.

#### Synthesis

Hold a discussion with the students to do examples 12.1-12.5. This will solidify their understanding of refractive index.

Let the students understand example 12:6-12:8. This can be discussed after they have done activity 12.7

Through question and answer method arrive at

$$\frac{\sin i}{\sin r} = \text{constant}$$

Let the students appreciate that the “constant” has no units. The constant is called refractive index (2). The direction of light or the interface in air / glass interface.

Explain

Draw student attention to table 12.2

### Assignment

Select some questions in exercise 12.2 and practice problem solving

Give exercise 12.3 as a takeaway assignment in students book page 351-352.

### Answers to activities 12.5 to 12.7 student's book

Refer to the discussion given in the student's book after every activity

### Teaching guidelines for activities 12.8

- Organise learners into appropriate groups, that is, if the class is a mixed one, ensure you have the gender balance (i.e., equally number of boys and girls if possible) and also they are of different abilities. This will help learners to appreciate the factor that all students (whether boys or girls) should be given equal opportunity to learn and also to promote cooperation among them.
- Review reflection on plane surfaces where  $i=r$
- Provide learners with Semi circular glass block, Paper protractor, Prism to do activity 12.8 in the student's book page 353.

- Use a semi- circular glass block to demonstrate total internal refraction. Then ask them to activity 12.8
- Guide them through the activity to determine critical angle of glass. Let the student calculate the value of .

### Synthesis

Through class discussion let the students arrive at  $n = n$

Guide them through the discussion given in the student's book.

Discuss examples 12.9 – 12.11 on the chalkboard with learners

### Assignment

Ask learners to do questions 1-3 of exercise 12.4. Mark their work and guide them appropriately.

### Answers to activities 12.8

Refer to the discussion given in the student's book after the activity.

## Lesson 2: Refraction of light through a prism

### Learning objective

At the end of this lesson the student should be able to

- i. Explain refraction of light through a glass prism
- ii. Explain dispersion of white light and combination of colours
- iii. Give the applications of total internal reflection

### Teaching aids

- An equilateral prism (angle 60°)
- Right angles prism
- Source of white light
- Prism periscope
- White plain paper



- White screen
- Mathematical set

### Introduction to the lesson

Show to the class the two types of glass prisms. Ask them to measure the angle of triangle making the bases of the glass prisms. Through probing questions. Arrive at which prism is

- Equilateral
- Right angle prism

### Learning activities

#### Teaching guidelines for activities 12.9-12.12

- Ask learners to organise themselves into appropriate groups depending on the availability of suggested learning resources. Go around checking whether the formed group according to the expectation, if not regroup them and emphasize the importance of observing gender balance (in case of a mixed class) and different abilities. This is important because it gives learners any opportunity to organise themselves hence promoting organisational skills in them.
- Ask them do activity 12.9 provided in the student's book page 355-356. Through doing the activity together in groups, the learners will realise the importance of teamwork and cooperation in doing a particular task hence promoting these competences in them.
- Once they are through with the activity, let them continue with activity 12.10.
- Through activity 12:10 make the students to realize that white light is made of 7 colours. Let them describe through group discussion what in mono chromatic and non-monochromatic light. Using wave concept explains the formation of 7 colors.

- Ask them use activity 12.11 to show total internal reflection of light by a prism.
- Guide them the three activities and ask them to give a summarized report on each.
- Through question and answer method let the student appreciate how total internal reflection by a prism is used in prism, periscope, optical fibre, rainbow and mirage. Use activity 12.12 to describe application of total internal reflection by prism. Filter is used to produce monochromatic light.

### Synthesis

Hold a class discussion to explain the concepts given in the student's book.

Guide the student to understand task of making a prism periscope to have hand – on activity.

Hold the discussion with the student and discuss examples 12.12 and 12.13.

### Assessment

Let questions 4-10 in exercise 12.4 be done under supervised practice.

Give exercise 12.5 as a study exercise that's students do the exercise in study group.

### Answers to activities 12.9-12.12 student's book

Refer to the discussion given in the student's book after every activity.

### Lesson 3: Refraction of light through a thin lens

#### Learning objective

By the end of this unit the learners should be able to

- explain refraction through a thin lens
- locate images formed by thin lens

- use lens formula and power of lens in solving problem in lens
- describe lens defects and their correction.

### Teaching aids

- Thin lenses
- Screen
- Water
- Rounded bottomed flask
- sun
- plain paper
- retort stand

### Introduction to the lesson

Let the student draw types of lenses. Then ask them to identify and hence describe the term used in thin lenses. Guide them to ensure they have understood the concepts because they will be required to apply any idea they may have on lenses.

### Learning activities

#### Teaching guideline for activities 12.13-12.15

- You have already grouped the learners before when they were doing activity 12.12, you may decide to maintain the groups for this activity or form new groups. Forming new groups sometimes is important because it helps learners to interact and share new ideas from different learners. It also promotes teamwork, cooperation among them.
- Ask learners to do activity 12.13 provided in the student's book page 367.
- Demonstrate to the learners the activity and allow learners to do the activity by their own.

- Hold a class discussion on their findings.
- Once they finish, let them do activities 12.14 and 12.15 given in the student's book.

### Synthesis

Hold a class discussion with learners and let them understand the meaning of a lens, types and terms used as discussed in the student's book.

Take the learners through the discussion given in the student's book to clarify the facts obtained from the activity.

### Assessment

Ask learners to do all questions of exercise 12.6 in the student's book page 373.

### Answers to activities 12.13-12.15 student's book

Refer to the discussion given in the student's book after every activity.

### Teaching guidelines for activities 12.16 to 12.27

- In each activity, ensure that you have grouped learners into convenient pairs, small groups or large one depending on the availability of the materials. It is a good idea to reorganize the groups after every activity or two if you think it is important to do so.
- Let them choose group leader and secretary who will be leading them through the activities.
- In each activity, provide learners with the materials suggested in the student's book on each of them.
- Every time, ask learners to do the activity and discuss their findings within the group.

- Once they finish the activity, ask the secretaries to give a brief summary on their findings to the whole class.
- Guide them through the discussion on their findings and guide them appropriately.

### Synthesis

Learners having done the activity hold a constructive and discuss the facts given in the student's book after every activity from activity 12.16 to 12.27. This is important because it will help learners to see errors on their finding and correct them hence enabling them to understand the concepts required in each section.

Emphasis the use of real, virtual magnified demolished, upright, inverted, at infinity, at  $2F$ , at  $F$  between  $f$  and optical center in stating the character or nature of image formed by both convex and concave lenses.

Use the formula  $\frac{1}{f} = \frac{1}{u} + \frac{1}{v}$  to solve problem in law.

Discuss with them examples 12.14-12.22 given in the student's book on the chalkboard.

### Assessment

Ask the student to attempts the exercises 12.6-12.8 given in the student's book pages 373, 381 and 389-392.

Practice the use of sign convention by discussion and come up with practice exercise that can help them to master them well.

Select some numerical question to practice use of  $M = \frac{v}{u}$  and power =  $\frac{1}{f}$

### Answers to activities 12.16-12.27 student's book

Refer to the discussion given in the student's book after every activity.

### Summary of the unit

- At random, ask different learners to lead others in brief discussion of different concepts highlighted in the unit summary given the student's book page 397-399. By asking them probing questions, help them recall the concepts.
- Ask learners to go back to the unit focus activity given on pages 332-333. Let them now give the correct solutions to the questions asked therein. Since the questions have been answered at one instance within the unit, help them to understand how to give correct answers.

### Additional information

The paper protractor is made by photocopying the real protractor

Reflective index can be used to identify substance.

The bordering between two media is also called interface.

No effort should be spared in order for the students to be able to use "no parallax method"

### Lesson 4: Unit assignment

Ask learners to do questions all questions in the unit test as a CAT. Supervise them and mark their work. Guide them appropriately.

Form study groups and give the groups specific but different problem to solve and report to the rest the class.

### Remedial activities

After each lesson identify weak students. Encourage them to form small study

groups through which you can reach the more effectively. Allow them to try the activities individually. In this way you can help them to catch up with the rest of class.

### Extended activities.

These activities are good in order you take care of fast learners. In most cases two parallel activities are suggested in order to take care of learners with different learning abilities e.g. in determination of refractive index, two activities are given. One using a ray box and the other one using pins is slightly challenging since it involves the use of no parallax method in locating the image

### Answers to numerical questions in exercises and unit test 12

#### Exercise 12.2

(Learner's book page 345-346)

3. (a)  $50^\circ$  (b)  $35^\circ$  (c) 1.34  
 5.  $1.88 \times 10^8$  m/s  
 6 (b)  $48.6^\circ$   
 7. Refer to the students book  
 8.

$i^\circ$	$r^\circ$	$\sin i$	$\sin r$
15	10	0.26	+0.17
30	19	0.5	0.33
45	28	0.71	0.47
60	35	0.87	0.57

Shape = 0.67

$$\text{ang} = \frac{1}{\text{ang}} = \frac{1}{0.67} = 1.492 = 1.5$$

#### Exercise 12.3

(Learner's book page 389-392)

1 - 3 (Consider learners argument)

4. First calculate the refractive index of the liquid using  $n = \frac{x}{12}$  and  $n = \frac{y}{18}$ .  $x = 12n$  and  $y = 18n$ .  $x + y = 40 = 30n$ ,  $n = 1.33$ . then calculate the real depth of air bubbles from one side, 16 cm from left side or 24 cm from right side.  
 5. (a) 1.33  
 (b) velocity

6 - 8 (Consider learners argument)

#### Exercise 12.8

(Learner's book page 389-392)

1 - 10 (Consider learners argument)

11. -24 cm as the image is virtual,  $f = 8$  cm  
 12.  $V = -100/9$ ;  $IM = 1.7$ cm, virtual image  
 13. 25 cm  
 14. (a) 60 cm ;  $IM = 6$ cm, real image (b)  $u = 10$  cm,  $V = -20$  cm,  $M = 2$   
 15. (a) 80 cm (b) 16 cm  
 16. 33.3 cm  
 17. (a)  $V = -10$  cm  
 (b)  $1/3$   
 18. 24 cm  
 19. 72 cm  
 20. (ii) 15 cm

#### Unit test 12

(Learner's book page 399-405)

1. C  
 2. A  
 3. B

4. A
5. B
6. A
10. (b) 1.45 (b) 14.60 , 68.70
11. 2.40
12.  $21.6^\circ$
14. 1.25
15. (b)  $2 \times 10^8$  m/s  
(c)  $3 \times 10^8$  m/s
20. (b) 3 cm from the lens  
(c)  $\frac{1}{2}$
21. (a) 24 cm on the same side of the object.  
(b) simple microscope
23. 75 cm
24. Check student's construction and accuracy.

**Key Unit Competence**

By the end of this unit, the learner should be able to differentiate telecommunication channels.

**Prerequisites to this unit**

For learners to acquire the knowledge skills, attitudes and values envisaged in this unit with ease, the need to have acquired the following:

- Basic knowledge of waves and the terms used to describe waves including wavelength, frequency, velocity and total internal refraction. The students briefly encountered some of these terms in the earlier topics of refraction of light and linear motion.

**Cross-cutting issues to be addressed**

The specific cross-cutting issues to be addressed in this unit are:

- **Environment and sustainability:** this issue will be addressed when the learners discuss the harmful effects of some wireless communication media like microwaves, infrared waves to the objects in the environment.
- **Standardisation culture:** This issue will be addressed as the learners analyse the quality of communication media. Under this section the teacher is expected to sensitize the learner on the importance of buying quality products including data communication media for simple communication systems at

home e.g, television antennae cabling and local computer network cabling

**Generic competences**

The specific generic competences to be addressed in this unit are:

- *Critical thinking:* This competence will be achieved when the teacher involve learners in activities that involve analyzing and comparing various aspects of communication media.
- *Communication skills:* This competence will be achieved when the teacher involve learners in discussions and making presentations on various aspects of communication media.

**Vocabulary/keywords**

In the course of learning the concepts in this unit, the learners will discover the meaning of the following new words:

- communication
- communication channel
- data signal
- analog and digital
- optical fibre
- attenuation
- Bandwidth

The teacher should guide the learners to understand the meanings of these words and construct and speak out sentences involving them in order to master their meaning and usage.



### Guidance on the problem statement

In order to give learners a purposeful reason and motivation to actively participate in lesson planned for this unit, facilitate them to do the Unit Focus activity outlined in the Pupils book page 407.

The activity involves identifying and evaluating the strengths and weakness of both traditional and modern means of communication media, and areas of application

Organize the learners into groups of threes to do the activity through discussions.

Let them present their findings to the rest of the class through a class discussion, as you as you and the rest of the class evaluate the accuracy of the facts presented.

It is most likely that most learner will use will not present very accurate and detailed description and analysis of modern communication channels, due to their limited knowledge of them so far. Appreciate all the groups for their participation and then let the class know that by actively participating in all the lessons planned for this unit, they will be able to critically analyse and evaluate communication channels

### Attention to special needs

The teacher should provide for learning of all learners including those with special needs.

The activities and the concepts to be discussed in this unit d may not be challenging to the specially gifted learners hence may get bored. The teacher needs to prepare additional more challenging questions and activities for these learners. For the slow learners, the teacher should organize remedial lessons where he/ she guides them through the activities

once again and more slowly to help them understand the concepts.

### List of lessons

Lesson No.	Lesson Title	No. of periods
1.	Definition of terms used in communication	1
2.	Types of data signals	1
3.	Data reansmission media	6
4	Unit Assessment	1
	Total	9

### Lesson Development

#### Lesson 1: Definition of terms used in communication

#### Learning objective

- The learner should be able define and explain the terms used in communication.

#### Teaching Aids

Chart showing a block diagram of a communication system.

#### Introduction to the lesson

Introduce the lesson by asking various learners to tell the class the meaning of the term communication. After this, let the class know that the objective of the lesson is identify and define the term communication and related terms.

#### Learning Activities

#### Teaching guidelines for Activity 13.1

Organise the learners in groups to do Activity 13.1 in the student's book page 407-408 that is to identify and discuss the terms used in communication.

Let the learners do the activity through a discussion as group secretaries write down the facts presented.

Ask groups to present their findings to the rest of the class through a class discussion, as you and the rest of the class gauge the accuracy of the facts presented. At the end of each group discussion, allow the other students to ask questions and seek clarifications from the presenting group.

#### **Synthesis**

Having done the activity, guide the learners through a class discussion to understand that:

- Communication is the process of using sounds, words, symbols, signs or pictures to pass a message or information from one person or object to another.
- Five basic elements of a communication system are: message source, transmitter, receiver, communication channel, receiver and message user. Guide them to understand the role and importance of each of these elements in a communication.

#### **Assessment**

Ask the learners to do questions 1, in Exercise 13.1 in the student book page 411.

#### **Answers**

##### **Answers to Activity 13.1**

1. Communication is the process of using sounds, words, symbols, signs or pictures to pass a message or information from one person or object to another.
2. Five basic elements of a communication system are: message source, transmitter, receiver, communication

channel, receiver and message user using.

## **Lesson 2: Types of data signals**

### **Learning objective**

The learner should be able to distinguish between digital and analogue signals

### **Teaching Aids**

Chart showing digital and analog signals.

### **Introduction to the lesson**

Introduce the lesson by asking learners to tell the class what they understand by digital migration as was successively effected and completed in Rwanda by 2015. Let them say the changes they have seen with the switching to digital transmission.

### **Learning Activities**

#### **Teaching guidelines for Activity 13.2**

Organise the learners in groups to do Activity 13.2 in the student's book page 409 distinguishing and comparing digital and analog signals.

Let the learners do the activity through a discussion as they write down the facts presented.

Let them present their findings to the rest of the class through a class discussion, as you and the rest of the class critique and seek clarifications from the group.

#### **Synthesis**

Having done the activity, guide the learners through a class discussion to understand:

- The difference between analog and digital signals as discussed in the student's book page 410-411.
- Advantages and disadvantages of digital and analog.

- How to determine frequency, wavelength and periodic time of digital and analog signals as discussed in the student's book page 410-411.

### Assessment

Ask the learners to do questions 2 to 7, in Exercise 13.1 in the student book page 411.

### Answers

#### Answers to Activity 13.2

1. Analog data is made up of continuous waveform while digital data is made up of a non-continuous discrete signal.
2. The main advantages of digital signals over analog signals are:
  - (i) Digital signals carry more information per second than analogue signals.
  - (ii) Digital signals maintain their quality over long distances better than analogue signals.

## Lesson 3: Data transmission media

### Learning objective

The learner should be able to:

- Outline different channels of communication.
- Explain difficulties related to signal transmission.
- Apply knowledge acquired to characterize quality of a communication system.
- Suggest different channels of communication applied in telecommunication.
- Evaluate difficulties experienced in communication system

### Teaching Aids

Open line cables

Coaxial cables

Twisted pair cables

Fibre optical cables

### Introduction to the lesson

Introduce the lesson by asking learners to give the two broad categories of data transmission media. The correct answer here should be cables and wireless communication media

### Learning Activities

#### Teaching guidelines for Activity 13.3

Organise the learners in groups to do Activity 13.3 in the student's book page 412. The activity involves identifying types of data transmission cables, describing their structure and evaluating their strengths and weaknesses.

Give the learners enough time to discuss and prepare a presentation.

Let them present their findings to the rest of the class through a class discussion, as you and the rest of the class critique and seek clarifications from the group. Ask them probing questions to help them analyse the cables in details

### Synthesis

After doing the activity, guide them to understand that there are currently for types of transmission cables:

- Open line cables
- Twisted pair cables
- Coaxial cables
- Fibre optical cables

Let them know that type of cable has its own structure, advantages and disadvantages.

## **Two-wire open line cable**

Through a class discussion, guide them structure of two-wire open line cable and its disadvantages discussed in the students book pages 412 - 413.

Help them understand the terms data rates, bandwidths, attenuation and electromagnetic interference.

## **Twisted pair cables**

### **Teaching guidelines for Activity 13.4**

Organise the learners in groups to do Activity 13.4 in the student's book page 413 on analyzing the use of cables in communication.

Let them present their findings to the rest of the class through a class discussion, as you and the rest of the class critique and seek clarifications from the group.

### **Synthesis**

After doing the activity guide the learners in a class discussion to help them clearly understand:

The difference between UTP and STP cables in terms of structure and functioning, as discussed in the student's book page 413-414. Lead them to understand the advantage and disadvantages of twisted pair cables.

Take them through Example 13.1 in students book page 414.

Help them understand the terms data rates, bandwidths, attenuation and electromagnetic interference.

## **Coaxial cables**

### **Teaching guidelines for Activity 13.5**

Organise the learners in groups to do Activity 13.5 in the student's book page 414 on analyzing the use of coaxial cables.

Let them present their findings to the rest of the class through a class discussion, as the rest of the class critique and seek clarifications from the group.

### **Synthesis**

After doing the activity use a pre-prepared chart to guide the learners in a discussion of the structure and function of each part of a coaxial cable, as discussed in the student's book page 414 - 416.

Lead them to understand the advantage and disadvantages of coaxial cables.

## **Fibre Optic cables**

### **Teaching guidelines for Activity 13.6**

Organise the learners in groups to do Activity 13.6 in the student's book page 416 to analyse the use of fibre optic cables in communication.

Let them present their findings to the rest of the class through a class discussion, as the rest of the class critique and seek clarifications from the group.

### **Synthesis**

After doing the activity use a pre-prepared chart to guide the learners in a discussion to help them clearly understand:

the structure and function of each part of a fibre optic cable, as discussed in the student's book page 416-418.

The concept of total internal reflection as applied in signal transmission through a fibre optic cable. You need to have prepared a diagram on a chart for this part before hand.

Lead them to understand the advantage and disadvantages of fibre optic cables

### **Assessment**

Ask the learners to do all questions of Exercise 13.2 in the student book page 418-420.

## Answers

### Answers to Activity 13.3 to 13.6

Refer to the discussion in the student's book pages 412-416.

### Wireless communication

#### Learning objective

The learner should be able to:

- Outline different channels of communication.
- Explain difficulties related to signal transmission.
- Apply knowledge acquired to characterize quality of a communication system.
- Suggest different channels of communication applied in telecommunication.
- Evaluate difficulties experienced in communication system

#### Teaching Aids

- TV set and its remote controller
- Two mobile phones
- A radio
- A chart showing satellite communication

#### Introduction to the lesson

Introduce the lesson by asking learners to name any mode of wireless transmission that they know. Some of expected correct answer should be microwave, radio wave, satellite transmissions and bluetooth technology.

#### Learning Activities

##### Teaching guidelines for Activity 13.7

Organise the learners in groups to do the Activity 13.7 in the student's book page

420. The activity involves matching modes of wireless transmission to the device that applies that technology.

Give the learners enough time to discuss and prepare a presentation.

Let them present their findings to the rest of the class through a class discussion, as you and the rest of the class critique and seek clarifications from the group. Ask them probing questions to help them analyse the cables in details

#### Synthesis

After doing the activity, guide them to understand that there are many wireless transmission including:

- microwave
- radio wave
- satellite,
- Bluetooth
- infrared

Let them know the mode of wireless transmission and its areas of applications, advantages and disadvantages.

Lead them in a discussion of the electromagnetic spectrum as outline in Fig.13.10 on page 421 of the student's book.

#### Microwave transmission

Through a class discussion, and with help of a diagram drawn on a chart, guide them to understand the point-to-point microwave transmission as demonstrated in the student's book pages 421.

#### Satellite communication

##### Teaching guidelines for Activity 13.8

Organise the learners in groups to do Activity 13.8 outlined in the student's book page 422 on illustrating and analyzing satellite communication.



Let them present their findings to the rest of the class through a class discussion, as you and the rest of the class critique and seek clarifications from the group.

#### **Synthesis**

After doing the activity guide the learners in a class discussion to help them clearly understand:

- The design of a satellite communication system as illustrated in the student's book page 422
- terms like uplink and downlink, earth station and space satellite, and VSAT technology as discussed in the student book pages 423.

### **Radio communication**

#### **Teaching guidelines for Activity 13.9**

Organise the learners in groups to do Activity 13.9 outlined in the student's book page 423 on illustrating and analyzing radio communication.

Let them present their findings to the rest of the class through a class discussion, as you and the rest of the class critique and seek clarifications from the group.

This will increase their communication skills critical thinking among other competence.

#### **Synthesis**

After doing the activity guide the learners in a class discussion to help them clearly understand:

- how radio communication takes place as illustrated in the student's book page 424.
- The categorization of radio waves as HF, VHF and UHF and how each category of radio waves is propagated

in the atmosphere as discussed in the student book pages 424-425.

### **Bluetooth and infrared transmissions**

Through a class discussion, guide the learners to understand how Bluetooth and infrared transmissions take place, as discussed in the student's book page 425-426.

Before winding up the lesson, discuss with the learners the advantages and disadvantages of wireless communication

#### **Assessment**

Ask the learners to do questions Exercise 13.3 in the student book page 427-428.

#### **Answers**

#### **Answer to Activity 13.3 to 13.9**

Refer to the discussion in the student's book after every activity.

#### **Unit Summary**

Through a class discussion, summarise all the key facts learnt in each of the four lessons. To do this, ask students probing questions to help them state the facts correctly and to the required depth.

Since the learners have now acquired the knowledge and skills envisaged in this unit, they are now able to redo the unit focus activity given at the start of the unit. To ascertain this fact, ask them to briefly explain how they can do that activity. If you judge they are able, ask them to redo it in groups.

#### **Additional information**

Signal transmission in an optical fibre occurs through continuous total internal reflection in the fibre. The overall diameter of the fiber is about 125  $\mu\text{m}$  and that of the core is just about 50  $\mu\text{m}$ . The difference



in refractive index of the cladding and the core allows total internal reflection in the same way as happens at an air-water surface shown in.

If light is incident on a cable end with an angle of incidence greater than the critical angle then the light will remain trapped inside the glass strand.

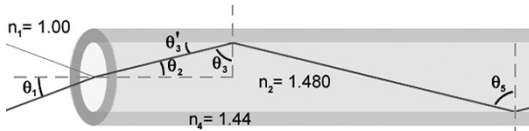

Figure TP13

In this way, light travels very quickly down the length of the cable over a very long distance (tens of kilometers). Optical fibers are commonly used in telecommunications, because information can be transported over long distances, with minimal loss of data.

### Unit assessment

Ask the learners to do Unit Test 13 given in the students book pages 429-431. Mark the test and use the students performance to identify those that need remedial work and those that need extended activities.

### Remedial exercises/Activities for slow learners

- Period is inverse of
  - Frequency
  - Phase
  - Amplitude
  - Signal
- Example of an analog to analog conversion is
  - Radio
  - Video
  - Television
  - Internet

- Which of the following communications channels, which does not provide a physical link between terminal and computer?
  - optical fiber
  - microwave
  - telephone lines
  - coaxial cable
- In practice, communications channels are often made up of several transmission media. Which of the following is likely connection between two computers?
  - microwave, satellite, telephone lines
  - microwave, satellite, coaxial cable
  - coaxial cable, telephone lines, optical fiber
  - none of the above
- A regular telephone line can transmit up to
  - 4.8K bps.
  - 22.8K bps.
  - 36K bps.
  - 56K bps

### Answers to remedial exercises for slow learners

- A
- A
- B
- C
- D

### Extended exercise/Activities for quick learners

- What factors should one consider when choosing a data communication channel
- Describe how total, internal reflection occurs in optical fibre.

3. Explain how crosstalk occurs in transmission media.
4. Differentiate between radio and microwave transmission
5. A data signal of frequency 1 000 Hz emits waves of wavelength 0.10 m . How long does it take for the wave to travel a distance of 2 500 m?
6. A radio is tuned to 600 m in the medium wave band transmitted from a broadcasting station. Determine the frequency of the waveband. (Speed of radio waves is 3 108 m/s).

### Answers to Exercises

#### Exercise 13.1 (Students book page 411)

Learner's book page 411

1. C 2. C 3. B 4. B 5. B
6. C 7. B

#### Exercise 13.2 (Learners book page 418-420)

##### Part 1

1. C 2. B 3. D 4. C 5. B
6. B 7. B 8. B 9. A 10. C
11. C 12. B 13. C

##### Part 2

1. Multimode, single mode
2. multiple signals in the core.
3. Total internal reflection
4. Number of signal in the core.
5. Refer to the students book pages 412-418.
6. Refer to the students book pages 416-418.

#### Exercise 13.3 learners book pages 427-428

##### Part A

1. A 2. B 3. C 4. A

##### Part B

1. Electromagnetic spectrum
2. UHF
3. Uplink, down link
4. Geostationary, 32
5. Foot print
6. VSAT

#### Unit test 13

##### Part A (Students book page 429 - 430)

1. A 2. C 3. A 4. A 5. B
6. B 7. B 8. C 9. C 10. A
11. (a) Fiber (b) UTP or fiber (c) fiber or coax (d) fiber (e) fiber (f) fiber, coax (g) UTP , fiber

##### Part B (Students book page 430 - 431)

12. Two wire open lines
13. Cross stalls
14. Single mode, multi mode
15. Line of single
16. Infrared
17. Bluetooth
18. Hot sport
19. Radio waves are propagated in all directions from a point source just like water waves. Micro waves move in a particular direction
20. Mobility, flexibility, use of portable devices

##### Part C (Students book page 431)

21. Refer to the learner's book page 411-428

**Key Unit Competence**

By the end of this unit the learners should be able to describe the physical properties affecting plant growth.

**Prerequisites to this unit**

For learners to acquire the knowledge skills, attitudes and values envisaged in this unit with ease, the need to have acquired the following:

- Knowledge of plants growth in their primary in science i.e. about photosynthesis. So before the teacher goes on to teach the learners, he/she must establish in all ways like using question and answer to establish that the learners remember these concepts before introducing them to this unit.
- Skills of digging or how to use a shovel because the learners will be required to collect different types of soil and getting them there must be use of a hoe or a spade

**Cross-cutting issues to be addressed**

The specific cross-cutting issues to be addressed in this unit are:

- *Environment and sustainability:* Since the unit will involve the learners working with soils, moving around in the bush collecting soil types, and using containers and bags, so the importance of disposing such waste materials safely to avoid polluting the environment..

**Generic competences addressed in this unit**

- Cooperation, interpersonal management and life skills through provision of group work
- Communication through provision of learner’s discussion based activities.
- Critical thinking and problem solving through involving the learners in problem solving and discussion

**Vocabulary/keywords**

In the course of learning the concepts in this unit, the learners the learners will discover the meaning of the following words:

- Moisture supply
- Radiant energy
- Biotic factors
- Growth-restricting substances
- Soil aeration and soil structure

Guide the learners to understand the meanings of these words and construct and speak them out in order to master their meaning, usage and applicability.

**Guidance on the problem statement**

In a way to make the learner’s get prepared and give attention to the unit, the teacher should organize learner to do the following unit focus activity in groups.

Materials: Reference books and internet enabled computers.

### Unit focus activity

- Organize learners into groups and provide them with the required material to do the unit focus activity in the student book page 433.
- Ask the learners to discuss and make presentation on environmental factors; temperature, moisture supply, radiant energy, composition of the atmosphere, soil aeration and soil structure, soil reaction, biotic factors, supply of mineral nutrients
- Ask them to discuss how temperature, moisture supply, radiant energy affect plant growth.
- Ask them to brainstorm on other factors that affect plant growth.
- Ask them to define biotic factors and explain how they affect plant growth.
- Let them debate on the impact of water, temperature, light, atmosphere, nutrients, fire and grazers on range plant productivity.
- Ask them to discuss and make presentation on physical properties of soil and their role in plant nutrition and growth. Let them use the internet to search on environment protection.
- The discussions and presentations will promote cooperation, communication skills, and confidence and leadership skills among other competences in the learners.

### Synthesis

- Use their feedback to guide them in such a way that leads to correct answers and responses to the questions asked in the activity.

- It is most likely that some will have right answers as they remember from their primary science thus correcting them somehow in their discussion can make them comfortable while entering into the unit well knowing they had ideas about it.
- For some like the slow learners, might come up with inaccurate answers, still use their responses to promote curiosity of the unit for them to see the need to learn it.
- Encourage them that the correct answers will be obtained in the process of learning the unit so that by the end of it they can be able to answer all the questions asked in the unit focus activity correctly.

### Attention to special needs

- In order to involve all the learners in the learning process, you must know all your learners especially the special need in your class.
- The unit comprises of numerous activities, you should involve the special need learners in these activities. For example, those activities that require use of legs can use hands where necessary and vice versa or they can just observe and give their suggestion.
- For slow learners, organize remedial lessons for them. Guide them through the activities and exercise once again and more slowly to help them understand.

## List of lessons

Lesson No.	Lesson Title	No. of periods
1.	Environmental factors and their impact on plant growth	2
2.	Composition of earth's atmosphere	1
3.	Soil properties and their impact on plant growth	2
4.	Biotic factors	1
5.	Unit assessment	1
Total		9

## Lesson Development

### Lesson 1: Environmental factors and their impact on plant growth

#### Learning objective

By the end of this section, the learners should be able to explain environmental factors and their impact on plant growth.

#### Introduction to the lesson

Introduce the lesson by asking learners from their primary science and geography the definition of environment and let them name factors from the environment that affect plant growth.

#### Teaching Aids

- Reference books
- Internet articles

#### Learning Activities

##### Teaching guidelines for Activity 14.1

- Organize learners into convenient groups making sure the groups are gender sensitive.
- Ask the learners to do activity 14.1 given in the student book on finding out environmental factors that affect plant growth naming some examples

as outlined on page 434.

- Ask them to discuss in their groups the meaning of environmental factors and name some examples. Working in groups enhances team work.
- Let them brainstorm on how temperature, radiant energy and moisture supply affect plant growth.
- Ask them to site other examples of factors that can affect plant growth.
- Ask them to share their findings to the rest of the class

#### Synthesis

Use a class discussion to help learners the facts in order to clearly understand:

- The meaning of environmental factors and the examples of the environmental factors as discussed in the student book on page 434.
- Let them appreciate that the plant distribution and growth is all limited by these environmental factors

#### Answers to activity 14.1

- In step 1, Environmental factors are all external conditions and influences affecting the life and development of an organism. They include among others Temperature, Moisture supply, Radiant energy, Composition of the atmosphere, Soil aeration and soil structure, Soil reaction, Biotic factors, Supply of mineral nutrients.
- In step 2, the radiant energy also known as sunlight if received well by a plant (up to a point), the better capacity it has to produce plant food through photosynthesis, the different colors of light are good for starting seedlings and the ability of many plants to

flower is controlled by photoperiod. Temperature affects Transpiration which increases with temperature, Respiration does also increase with temperature, Photosynthesis increases but to a certain point, Flowering is initiated by temperature and others. The amount of moisture present will determine a lot in photosynthesis.

- In step 3, some examples are absence of growth restricting substances.

#### Teaching guidelines for Activity 14.2

- Organize the learners into pairs being more care to encourage mixing of fast learners and slow learners.
- Ask the learners to do activity 14.2 in the students book page 434 to use their knowledge of science and biology to define light, and then research from the internet and reference books on how light is useful to plant growth.
- The activity involves doing research so it's the teacher's obligation to guide the learners on how to do the research.
- Let each member discuss to the rest of the class his/her research and findings.

#### Synthesis

Before concluding this section, hold a class discussion to ensure that the learners have understood the following concepts;

- Light is a form of energy. Light has three principal characteristics that affect plant growth: quantity, quality, and duration.
- Light quantity refers to the intensity or concentration of sunlight and varies with the season of the year.
- Light quality refers to the color or

wavelength reaching the plant surface.

- Light duration or photoperiod refers to the amount of time that a plant is exposed to sunlight.

#### Assessment

- Ask the learners to do Exercise 14.1 given in the student book pages 435-436.

#### Answer to activity 14.2

In step 1, light is a form of energy that helps the sensation of vision

In step 2,

Light quantity determines the capacity of plant food made through photosynthesis. Light quality has different effects because different colors have different effects. That is red and blue light have the greatest effect on plant growth. Green light is least effective to plants as most plants reflect green light and absorb very little. Blue light is primarily responsible for vegetative growth or leaf growth. Red light when combined with blue light, encourages flowering in plants. Fluorescent or cool-white light is high in the blue range of light quality and is used to encourage leafy growth.

Light duration can control the ability of many plants to flower.

#### Temperature

#### Learning objective

The learner should be able to explain how temperature as an environmental factor affects plant growth.

#### Teaching Aids

- Reference books
- Internet



## Introduction to the lesson

- The word temperature at this level must be familiar with every learner. Introduce the lesson by asking them to define temperature from their past experience.

## Learning Activities

### Teaching guidelines for activity 14.3

- Organize the learners into appropriate groups reflecting gender balance and mixed abilities.
- Draw the attention of the students to the student's book page 436. Ask them to do activity 14.3 to discuss the effects of temperature on plant growth as outlined on page 436-437.
- Ask them to use their knowledge of physics to define temperature.
- Ask them to use the library and go into biology, agriculture and geography books to get information on the aspects of plant growth that temperature affects directly.
- Ask them to present their findings to the whole class.

### Synthesis

Use a class discussion to help the learners have mastered that

- Temperature is a degree of hotness or coldness that can be measured using a thermometer.
- Temperature directly affects Photosynthesis, Respiration, Transpiration, Flowering, Sugar storage and Dormancy on plant growth.
- The factors that affect soil temperature are soil moisture, soil color, vegetative cover, slope of the land and general soil tilt.

## Assessment

Summarize the discussion by asking the learners to complete exercise 14.2 on page 437.

### Answer to activity 14.3

In step 1, Temperature is the degree of hotness or coldness of a body.

In step 2, on plant growth, temperature directly affects

- Transpiration which increases with temperature
- Respiration does also increase with temperature:
- Photosynthesis increases but to a certain point.
- Flowering is initiated by temperature
- Sugar storage; Low temperatures reduce energy use and increase sugar storage
- Dormancy: there is breakage of dormancy if warmth comes after a period of low temperature and it will make plants to resume active growth.
- absorption of water and nutrients
- Temperature also affects soil organisms.
- Soil temperature affects water and nutrient uptake.
- Temperature affects the productivity and growth of a plant depending upon whether the plant variety is a warm-season or cool-season crop

### Moisture supply (humidity)

#### Learning objective

The learner should be able to explain how moisture supply as an environmental factor affects plant growth.

## Teaching Aids

- Reference books
- Internet

## Learning activity

### Introduction to the lesson

The word humidity is not so new to most of the learners. Introduce the lesson by testing to see if they can still define it from their primary knowledge.

### Teaching guidelines for activity 14.4

- Organize the learners into pairs putting in mind that they have to be mixed, that is slow learners and fast learners to encourage inclusivity.
- Ask the learners to do activity 14.4 to discuss how moisture supply affects plant growth as outlined in the student book on page 438.
- Guide the learners as they are doing research on the meaning of moisture.
- Ask them to discuss how moisture affects plant growth.
- Ask the learners to harmonize their findings with the rest of the class.

### Synthesis

Before concluding this section, hold a discussion to ensure that the learners have mastered the following concepts;

- Moisture refers to the presence of a liquid, especially water, often in trace amounts in the air.
- Guide the learners through a discussion about moisture and how it affects plant growth as discussed in the student book page 438.
- Guide the learners to know that plant growth is always limited by low and

high levels of soil moisture and that good soil moisture improves nutrient uptake.

### Assessment

- Ask the learners to do a question in self-check to test their understanding on page 438 in the student book.

### Answers to activity 14.4

In step 1, Moisture also refers to the amount of water vapor present in the air.

In step 2, the water that is contained in the soil is called soil moisture. It is the major component of the soil in relation to growth of plants. The importance's of moisture to plants includes;

- i) Water is essential for photosynthesis
- ii) Water regulate transpiration in plants because it regulates the opening and closing of the stomata
- iii) Soil water regulates the temperature in the soil by its gradual evaporation from the surface of the leaf, near the stomata, thus helps to stabilize plant temperature
- iv) Soil water serves as a solvent and carrier of food nutrients within the plants for plant growth
- v) Moisture or water alone is a nutrient to plants
- vi) Soil water helps in chemical and biological activities of soil

### Supply of mineral nutrients

### Learning objective

By the end of lesson, the learner should be able to define mineral nutrients and know how the mineral supply affects plant growth and development.

## Learning Activities

### Teaching guidelines for activity 14.5

- Organize the learners into pairs.
- Ask the learners to do activity 14.5 to find out how the supply of mineral nutrients affects the plant growth as outlined in the student book page 439.
- Ask the learners to conduct a research about the supply of mineral nutrients and how they can affect the growth of a plant.
- Ask them to share their findings to the rest of the class.

### Synthesis

Before concluding this section, hold a class discussion to ensure that the learners can explain the following concepts

- Mineral nutrients are inorganic substances that must be ingested and absorbed in adequate amounts to satisfy a wide variety of metabolic and structural functions in the body.
- Put more emphasis on differentiating between plant nutrition and plant fertilization.
- Guide the learners through a discussion about the different types of minerals nutrients that plants are in need of and how they can be available as discussed in the student book on pages 439-440.

### Assessment

- Learners complete an exercise (refer to the students book 3 on pages 440-441 (exercise 14.3) for the exercise)

### Answers to Activity 14.5

In step 1, Plant nutrition refers to the needs and uses of the basic chemical elements in

the plant. Plant nutrients have different purposes for the plant, to begin with;-

- Nitrogen is necessary for plant cell divisions, formation of amino acids the building block of proteins, affects energy reactions in the plant, aids in production and use of carbohydrates
- Phosphorus is involved in photosynthesis, respiration, energy storage and transfer, cell division and enlargement, promotes early root formation and growth.
- Potassium is used in carbohydrate metabolism, increases photosynthesis, increases water-use efficiency, important in fruit formation

In step 2, Plants need 18 elements for normal growth. Carbon, hydrogen, oxygen, Nitrogen, phosphorus, potassium, magnesium, calcium, sulfur, the micronutrients, are iron, zinc, molybdenum, nickel, manganese, boron, copper, cobalt, and chlorine. All 18 elements, both macronutrients and micronutrients are essential for plant growth.

## Lesson 2: Composition of the earth's atmosphere

### Learning objective

The learner should be able to explain the composition of the earth's atmosphere.

### Learning Activities

#### Teaching aids

- Internet
- Reference books

## Introduction to the lesson

The word atmosphere is not a new word to the learners, introduce the lesson by asking them to define atmosphere. It is always good to learn from known to unknown.

### Teaching guidelines for activity 14.6

- Organize learners into convenient groups of two or three.
- Ask the learners to do activity 14.6 in the students book in their groups to describe the composition of the atmosphere as outlined on page 441.
- Ask them to research from the internet and reference books the composition of the atmosphere and how it affects plant growth.
- Ask them to name the gases found in the atmosphere.
- Ask the group leaders or secretaries to present their findings to the whole class.

### Synthesis

- Consolidate their work by discussing with them the composition of the atmosphere as outlined in the student book page 442.
- Let them appreciate that the composition of the atmosphere determines its ability to transmit sunlight and trap infra-red light, leading to long term changes in climate.

### Answers to activity 14.6

In step 1, the atmosphere consists of *many* gases.

In step 2, nitrogen (78%), oxygen (21%), argon (1%) and trace amounts of carbon dioxide, neon, helium, methane, krypton, hydrogen, nitrous oxide, xenon, ozone, iodine, carbon monoxide and ammonia.

## Lesson 3: soil properties and their impact on plant and growth

### Learning objective

By the end of the lesson the learners should be able to explain the properties of soil and their impact on plant growth.

### Teaching aids

- Clay
- Silt
- Sand soil
- Water
- Two beakers

### Introduction to the lesson

From the learners primary science they may have learnt different properties of soil using question and answer method prompt the learner about the properties they remember before you begin the lesson.

### Learning activity

#### Teaching guidelines for activity 14.7

- Organize the learners into pairs.
- Ask them to do activity 14.7 as outlined in the student book page 442-443. The activity is meant to help them appreciate how the soil structure affects plant growth.
- Encourage the learners to discuss their findings with rest of the class. Such discussion and presentation improves the communication skills of the learners.
- Ask them to share their findings to the rest of the class

### Synthesis

Use a class discussion to help the learners consolidate the facts in order to clearly understand that;

- Soil structure refers to the arrangement of soil particles into aggregates (or peds) and the distribution of pores in between.
- Guide the learners to know that soil structure affects plant growth in many ways as explained in the student book pages 444.

### Assesment

Ask learners to complete exercise 14.4 in students book pages 445-446.

#### Answers to activity 14.7

In step 1, Soil structure refers to the arrangement of soil particles into aggregates (or peds) and the distribution of pores in between.

Soil structure affects plant growth in many ways;-

- Increases infiltration of water, thus reducing runoff and erosion and increases the amount of plant available water.
- Improves seedling emergence due to reduced crusting of the surface
- Large continuous pores increase permeability.
- reduced erosion due to greater soil aggregate strength and decreased overland flow
- Improved root penetration and access to soil moisture and nutrients

### Learning activity

#### Teaching guidelines for activity 14.8

- Organize the learners into pairs.
- Ask them to do activity 14.8 in the student book to compare soil aeration as outlined on page 446-447.

- Ask them to discuss in their pairs what soil aeration means.
- Ask them to discuss how soil aeration is important to plant growth and development.
- Encourage the learners to discuss their findings with rest of the class. Such discussion and presentation improves the communication skills of the learners

### Synthesis

Through a class discussion, help all learners to fully appreciate that the soil aeration involves perforating the soil with small holes to allow air circulation, water and nutrients to penetrate the grass roots. Let them appreciate the Importance of Soil Aeration as discussed in the student book page 447-448.

### Assessment

Ask the learners to answer exercise 14.5 in the student book page 448 and exercise 14.6 on page 450-451.

#### Answers to activity 14.8

In step 1, soil Aeration involves perforating the soil with small holes to allow air, water and nutrients to penetrate the grass roots.

In step 2, Poor aeration results in the development of toxin and other injurious substances, the microorganisms living in the soil also require oxygen for respiration and metabolism, good water and nutrient absorption, Insufficient aeration of the soil also leads to the development of diseases.

### Soil texture and soil reaction

#### Learning objective

The learner should be able to explain soil reaction and texture.

## Teaching Aids

- Reference books
- Internet

## Synthesis

Through a class discussion.

- Guide the learners to know that soil PH is the measure of the acidity or alkalinity in soils.
- Take them through a discussion of the effects of soil reaction as outlined in the student book page 451-452.

## Assessment

- Ask the learners to do Exercise 14.7 given in the student book pages 452.

## Lesson 4: Biotic factors

### Learning objective

The learners should be able to explain biotic factors.

## Teaching Aids

- Research books
- Internet

## Learning activities

### Teaching guidelines for activity 14.9

- Organize the learners into groups
- Ask the learners to do activity 14.9 in the students book to find out what a biotic factor is as outlined on page 452-453.
- Ask the learners to conduct a research about biotic and abiotic factors.
- Let them explain and give examples from their research.

- Ask them to define an ecosystem.
- Ask the learners to share with the rest of the class their findings by choosing one representative.

## Synthesis

Through a class discussion, guide the learners to understand the following concepts;

- That the word the word “bio-” means life, therefore a biotic factor is any activity of a living organism that affects another living organism within its environment.
- While biotic means living, and biotic factors are the other, living parts of the ecosystem with which an organism must interact in that ecosystem, abiotic factors are chemical and physical factors such as temperature, soil composition, and climate, along with the amount of sunlight, salinity, and pH.
- The examples of biotic components as given in the student book page 453-454.
- Let them understand that an ecosystem is defined as any community of living and non-living things that work together.

## Assessment

Ask the learners to do Exercise 14.8 given in the student book page 454.

### Answers to Activity 14.9

In step 1, biotic factor is any activity of a living organism that affects another living organism within its environment, and abiotic factors are the other, living parts of the ecosystem with which an organism must interact in that ecosystem.



In step 2, Examples of Biotic Factors include competition for food, predator-prey relationships, parasitism, and diseases where as abiotic factors found in aquatic systems are water depth, pH, sunlight, Abiotic variables found in terrestrial ecosystems can include things like rain, wind, temperature, altitude, soil, pollution, nutrients, pH, types of soil, and sunlight.

In step3, an ecosystem is defined as any community of living and non-living things that work together.

### Summary of Unit

Summarize the unit by:

- Asking different learners to take the class through the different concepts highlighted in the unit summary given in the learner's book page 455. Ask the class probing questions to help them recall the concepts correctly.
- Now ask the learners to describe the solution to the problem faced during the unit focus activity at the beginning of the unit. After their response, ensure that the learners are able to
  1. Define and give brief accounts on environmental factors
  2. Explain the difference between biotic and abiotic factors and explain they affect plant growth and development
  3. Describe physical properties of soil and their role in plant nutrition and growth.

Guide the learners as they answer the above questions giving them time to internalize the questions.

### Additional information to the teacher

- Soil aeration can also be defined as

the movement of air I the soil mass resulting in the renewal of gases. Thus a well-aerated soil is one which gases are available to growing aerobic organisms. It is important because it largely controls the soil levels of two sustaining gasses i.e. oxygen and carbon dioxide which take part in respiration of the roots as well as soil microorganisms

- Soil aeration influences soil properties and soil reaction. The most important of these reactions are associated with microbial breakdown of organic residues. Poor aeration slows down the rate of decay, i.e. oxygen gas content of the soil determine the decay of organic matter
- Soil PH is a measure of the concentration of hydrogen ions in the soil solution.
- Let them know that PH levels range from 0-14 with 7 being neutral, below seven being acidic and above seven alkaline as outlined in the student book page 451. Guide them to know that the optimal PH range for most plants is 5.5 and 7.0; however many plants have adapted to thrive at PH values outside this range.

### Remedial activity for slow learners.

1. Why is light important for plant growth?
2. Why is temperature an essential environmental factor for plant growth?
3. Why is water considered to be an essential environmental factor?

### Answers to remedial activity for slow learners.

1. Light helps in the following to plants;-

- (i) Light energy permits all life form on earth
  - (ii) Plants capture and transform light energy for growth
  - (iii) Without light, plants green color will die away and plants will die
2. Temperature controls the rate of reactions or processes in the plant like;-
    - (i) Germination
    - (ii) Transpiration
    - (iii) Respiration
    - (iv) flowering
  3. the importance of water to plants include;-
    - (i) it is necessary for plant cell enlargement
    - (ii) water helps maintain cell turgor
    - (iii) water is necessary for photosynthesis
    - (iv) water provides transport medium to carry various essential elements within the plant
    - (v) water cools the plant via transpiration
    - (vi) Water acts as a solvent carrying dissolved sugars and other organic substances throughout the plant.

**Remedial activity for gifted learners.**

1. Why is air an important environmental factor for plant growth
2. How do plants get water?
3. What effect does irrigation and stored water have on plant growth?
4. What factors influence temperature?

**Answers for remedial activity for gifted learners.**

1. Air surrounds the aerial part of the plant and in it, there is oxygen and carbon dioxide.
  - (i) Carbon dioxide required for photosynthesis
  - (ii) Oxygen required for respiration
2. Plants receive water in a number of ways;-
  - (i) Irrigation
  - (ii) Precipitation
  - (iii) Fog and dew
  - (iv) Stored surface and ground water
3. Each one affects the plant differently;-
  - (i) Irrigation water will affect plant growth like it supplements in the dry season or helps make the desert into a highly productive farmland
  - (ii) Stored water on the surface or underground also serves the same purpose as a supplement either directly or from irrigation.
4. Temperature is influenced by many factors like;-
  - (i) Soils- different types of soil warm up differently with sandy soil warming fast, loam, silt and clay second and organic warming up least
  - (ii) Ocean effect- large water bodies warm and cool much slowly than soil. This accounts for more moderate temperatures along coasts.

- (iii) Altitude- temperatures decrease with altitude.
- (iv) Latitude- temperature differences are caused by day length and the angle at which the sun's radiations hit the earth's surface.

- Absorption of water and nutrients.
- Temperature also affects soil organisms. Nitrifying bacteria inhibited by low temperature. pH may decrease in summer due to activities of microorganisms.
- Soil temperature affects water and nutrient uptake.

#### Answers to exercises and unit test 14

##### Exercise 14.1 On page 435-436

1. D
2. A
3. A
4. B
5. A

##### Exercise 14.2 On page 437

1. Soil temperature can be controlled by;
  - (i) Regulating soil moisture
  - (ii) Proper soil management practices so as to have good drainage
  - (iii) Application of mulching
  - (iv) Sufficient addition of organic matter
2. On plant growth, temperature directly affects
  - Transpiration which increases with temperature
  - Respiration does also increase with temperature:
  - Photosynthesis increases but to a certain point.
  - Flowering is initiated by temperature.
  - Sugar storage; Low temperatures reduce energy use and increase sugar storage
  - Dormancy: there is breakage of dormancy if warmth comes after a period of low temperature and it will make plants to resume active growth.

##### Slef check exercise on page 438

1. The water that is contained in the soil is called soil moisture. It is the major component of the soil in relation to growth of plants. The importance's of moisture to plants includes;
  - (i) Water is essential for photosynthesis
  - (ii) Water regulate transpiration in plants because it regulates the opening and closing of the stomata
  - (iii) Soil water regulates the temperature in the soil by its gradual evaporation from the surface of the leaf, near the stomata, thus helps to stabilize plant temperature
  - (iv) Soil water serves as a solvent and carrier of food nutrients within the plants for plant growth
  - (v) Moisture or water alone is a nutrient to plants
  - (vi) Soil water helps in chemical and biological activities of soil

##### Exercise 14.3 On page 440-441

1. A
2. C
3. D
4. B

5. Refer to work in the students book
6. (a) phosphorus (b) iron  
(c) Magnesium (d) potassium

**Exercise 14.5 On page 445-446**

1. A
2. B
3. D
4. D
5. C
6. Ways of maintaining a good soil structure include
  - (i) Till soil only at the proper moisture contents. Never till when the soil is too wet. This will cause the soil to become cloddy. Aggregates are easily destroyed.
  - (ii) Add the proper amounts of lime and fertilizer. Proper plant growth will lead to the development of good soil structure.
  - (iii) Grow grasses and legumes. These plants may help form unstable aggregates and their organic matter will help stabilize the aggregate.
  - (iv) Growth of legumes will also give the soil more microorganisms which give certain beneficial fungi which will stabilize peds.
  - (v) plant cover crops in fall and winter
  - (vi) plant more grasses
  - (vii) turn under crop residue
  - (viii) Add manure.
7. The importance of soil structure in plant growth and development include
  - (i) It Increases infiltration of water, thus reducing runoff and erosion and increases the amount of plant available water.

- (ii) It Improves seedling emergence due to reduced crusting of the surface
- (iii) Large continuous pores increase permeability.
- (iv) It reduce erosion due to greater soil aggregate strength and decreased overland flow
- (v) It Improves root penetration and access to soil moisture and nutrients
8. A well-structured soil forms aggregates that don't fall apart easily and has many pores. A well-structured soil is friable, easily worked and allows germinating seedlings to emerge and to quickly establish a strong root system. On the other hand, a poorly structured soil has either few or unstable (readily broken apart) aggregates and few pore spaces. A poorly structured soil can result in unproductive compacted or waterlogged soils that have poor drainage and aeration. Poorly structured soil is also more likely to slake and to become eroded.
9. Soil structure is the way individuals particles of sand, silt and clay are assembled and aggregates are groups of soil particles held together by organic matter or chemical forces

**Exercise 14.5 On page 448**

1. B
2. A
3. C
4. B
5. A
6. Refer to work in the students book

**Exercise 14.6 On page 450-451**

1. D
2. C
3. A
4. C

5. 2
6. C
7. D
8. B
9. D
10. D

11. (a) silt (a) feel gritty, often dry and fast draining  
 (b) clay (b) feel smooth, silky and have a tendency to form crust  
 (c) sand (c) high water holding

**Exercise 14.7 On page 452**

1. A
2. A
3. C
4. B
5. D

**Exercise 14.8 On page 454**

1. B
2. B
3. C
4. B
5. A
- 6.

Biotic	Abiotic
<ul style="list-style-type: none"> <li>- herbivory</li> <li>- parasitism</li> <li>- competition for food</li> </ul>	<ul style="list-style-type: none"> <li>- salt concentration</li> <li>- sunlight</li> <li>- soil pH</li> <li>- water depth</li> <li>- rain</li> <li>- rain</li> <li>- wind</li> <li>- temperature</li> <li>- pollution</li> </ul>

**Unit test 4 on page 455-458**

**Multiple questions**

1. E
2. B
3. C
4. B
5. B
6. B
7. A
8. A
9. A
10. C
11. B
12. E
13. D
14. A
15. B
16. A
17. C
18. A
19. A
20. C
21. Answers in the correct order are:
  - -phosphorus
  - ammonium nitrate
  - hydrogen
  - oxygen
  - macro nutrients
  - micro nutrients
  - macro nutrients
  - macro nutrients
  - soluble

**Key Unit Competence**

By the end of this unit, the learners should be able to relate physics concepts with environmental phenomena.

**Prerequisites to this unit**

For learners to acquire the knowledge skills, attitudes and values envisaged in this unit with ease, the need to have acquired the following:

- Knowledge of the laws of thermodynamics and environment as we had looked at it in unit 14 of book 3. This will help them in the coming discussions which are related to the environment and climate.
- Knowledge of the modes of heat transfer. That is state and explains the different form of heat transfer.

**Crosscutting issues to be addressed.**

The specific crosscutting issues to be addressed in this unit are:

- Environment and sustainability: Since the unit will involve the learners learning about how the environment is conserved through sections like global warming, greenhouse effect and others, sensitize the learners on the above effects and how they should keep the environment free from such problems. Also in this unit, learners will pick litter around the school and burn it.

- Inclusive education: The unit has wide range of activities and exercises that encourage inclusiveness of every learner.

**Generic competences**

The specific generic competences to be addressed in this unit are:

- Critical thinking: This competence will be achieved when the teacher involves learners in activities that involve explaining and brainstorming of concepts in the unit.
- Problem solving: This competence will be achieved when the teacher involve learners in activities and exercises.
- Cooperation, interpersonal management and life skills through provision of group work.
- Communications skills through provision of learner’s discussion based activities.
- ICT: This competence will be achieved when the teacher will involve learners in conducting research from the Internet.

**Vocabulary/keywords**

In the course of learning the concepts in this unit, the learners will discover the meaning of the following new words:

- Global warming
- Greenhouse effect
- Climate change



- Global convection currents
- Global wind patterns
- Cyclone and anticyclones
- Clouds
- Ozone layer

Guide the learners to understand the meanings of these words and construct and speak out mathematical statements involving them in order to master their meaning and usage.

### Guidance on the problem statement

In a way to make the learners get prepared and give attention to the unit, the teacher should organize learner to do the following unit focus activity in groups, remember they have got a hint about it from subjects like biology and geography.

### Unit focus activity

- Divide the students into small groups, for example a group of 5 learners.
- Ask them to activity in the student's book page 460 in their groups how the global climate has changed, and the causes and impacts of climate change in the world, and ways in which we can control climate change.
- Ask them the causes and impacts of noise pollution, air pollution and how pollution can be minimized in general.
- Ask them how laws in physics, mainly laws of thermodynamics and modes of heat transfer govern processes in our environment.
- Such discussions and the presentation improves the communication skills of the learners.
- Let one of the group members represent his/her group their findings

to the whole class in a class discussion.

### Synthesis

- Through a class discussion, help the learners to appreciate that the environmental processes influence a lot in our lives, for example, climate change is the main cause of prolonged drought and over flooding in some parts of the world. It is therefore important for everyone in the world to learn how environmental process take place and the physics behind them, in order understand each one should be involved in conserving our environment for our sake. This is what learners will gain as we discuss various environmental phenomena and the physics laws governing them in this unit.

### Attention to special needs

- You should provide for learning of all learners including those with special needs.
- For the slow learners, organize remedial lessons where he/she guides them through the activities once again and more slowly to help them understand the concepts.

### List of lessons

Lesson No.	Lesson Title	No. of periods
1.	Environment and energy transfer	1
2.	Application of law of thermodynamic in energy transfer environment	1
3.	Modes of heat transfer in the environment	1
4.	Noise pollution	1
5.	Air pollution	1
6	Structure and composition of the atmosphere	1

7	Climate change science	1
8.	Hydrosphere and hydrologic cycle	1
9.	Clouds	1
10.	Cyclones and anticyclones	1
11.	Global convection currents and wind patterns	1
12.	Thermoregulation and the physics laws that are governing it	1
	Total	12

## Lesson Development

### Lesson 1: Environment and energy transfer

#### Learning objective

The learner should be able to recall modes of heat transfer and explain the meaning of environment.

#### Teaching Aids

- Reference books
- Internet

#### Learning Activities

##### Teaching guidelines for Activity 15.1

- Organize the learners into groups.
- Ask them to do Activity 15.1 in the student's book on explaining how the laws that govern heat transfer in the environment as outlined on page 461.
- Ask them to explain why heat energy flows from hot to a cold region and not the reverse.
- Ask them to discuss how heat travels from the sun through a vacuum in outer space to reach the earth, and how sea and land breezes occur the following environmental phenomena.

- Ask one member from the group to present their findings to the class and from which you will have what to consensus with them.

#### Synthesis

Having done the activity, guide the learners through a class discussion to understand that:

- The natural environment encompasses all living and non-living things occurring naturally on Earth or some region thereof.

#### Answers to Activity 15.1

- In step 1, a) from the first statement of second law of thermodynamics-heat flows spontaneously from hot to cold. The explanation lies from the description of temperature. A hot body has particles moving very fast and a cold body moving slowly. When they are in contact, they collide like in conduction and transfer some of their kinetic energy and fast moving atoms reduce their speed and slow moving particles increase their speed.

In step 2, heat from the sun reaches the earth in form of electromagnetic radiations in a method called radiation.

Sea breeze occurs during a hot day. During the day, the land surface heats up faster than the water surface. Therefore the air above the land is warmer than above the ocean. Since warm air is lighter than cold air, it rises and the cooler air over the ocean flows over the land surface to replace the rising warm air. For a land breeze it is created when at night. The land surface cools quicker than the water surface. Therefore the warm air over

the ocean is buoyant and rises. The denser cool air over the land then flows in to replace the rising air.

### **Lesson 2: Application of laws of thermodynamics in heat transfer in the environment**

#### **Introduction to the lesson**

In unit 6, the learners covered the laws of thermodynamics. You may use questions and answers method to make the learners recall what they had covered, this knowledge is important in this unit.

#### **Teaching guidelines**

Give the learners a small quiz and allow them to do some research on the applications of the laws of thermodynamics in energy transfer in the environment.

Let them discuss in groups the applications as they note them down.

#### **Synthesis**

Guide the learners through the discussion given in the learners book page 461, for them to understand the different aspects that are outlined.

### **Lesson 3: Modes of heat transfer in the environment**

#### **Learning objective**

The learner should be able to explain the different modes of heat transfer in the environment.

#### **Learning activity**

##### **Teaching Aids**

- Metallic rod
- Heating source
- Water in a beaker
- Ink

- Candle wax
- Small nails
- Retort stand
- Tripod stand
- Steel wire

#### **Preparation to the lesson**

Before the lesson, prepare a set of the materials mentioned above for each of groups you will work with.

#### **Learning activity**

##### **Teaching guidelines for Activity 15.2**

- Organise the learners into groups.
- Guide them to do activity 15.2 to describe modes of heat transfer in the environment as outlined in the student book pages 462-463.
- Ask them to discuss if the temperature increases in one object will always equal to the temperature decrease in the other when heat flows between two objects.
- Ask them to describe how the thermal energy of an object changes when the temperature of an object changes.
- Let them explain the three modes of heat transfer in the environment.
- Ask them to share their findings to the rest of the class. Such discussion and presentation improves the communication skills of the learners

#### **Synthesis**

Through a class discussion, help all learners to fully appreciate that;-

- Conduction is the transfer of thermal energy or movement of heat through a substance without the substance itself moving as explained in the student book page 463.

- Convection is the transfer of thermal energy in a fluid by the movement of warmer and cooler fluid from place to place as outlined in the learner's book page 464.
- Radiation is the transfer of energy by electromagnetic waves as outlined in the learner's book pages 464-465.

### Assessment

Ask the learners to do exercise 15.1 given in the student book page 465.

### Answers to activity 15.2

- In step 3, the nails will start falling off after some time. This is because the candle wax melts as soon as it is heated. The wax is heated because heat moves from the end of the rod that is heated through the rod to the wax thus melting and releasing the nails to fall down.
- In step 4, the arm is going to feel warmth as it is brought besides the Bunsen burner. Heat has moved from the Bunsen burner in space to your arm.
- In step 5, the steel wire is to spread the heat such that it heats every part at the bottom of the beaker.
- In step 6, the ink in the beaker is seen to rise up and fan outwards and then later seen again to go to the bottom. When water is heated, it expands and becomes less dense thus rising. The cold more dense liquid sinks to replace it.
- In step 7, the observation is the same as in step 4.
- In step 8, no. the amount of temperature increase or decrease will depend on the mass of the substance and the heat capacity of that substance.
- In step 9, thermal energy of an object will increase or reduce when the temperature increases or reduces. This is because the thermal energy is apart from the potential energy of the particles but also determined by the average kinetic energies of the particles, which is temperature.
- In step 10, Conduction is the transfer of thermal energy or movement of heat through a substance without the substance itself moving. Convection is the transfer of thermal energy in a fluid by the movement of warmer and cooler fluid from place to place. Radiation is the transfer of energy by electromagnetic waves.

## Lesson 4: Noise Pollution

### Learning objective

The learner should be able to explain noise pollution as an environmental problem that is faced by people in this world

### Teaching Aids

- Radio
- Internet
- Reference books

### Introduction to the lesson

The words noise and pollution may not be new to most learners. Introduce the lesson by asking learners to suggest what they think of noise, pollution and noise pollution

### Learning Activities

#### Teaching guidelines for Activity 15.3

- Organize the learners in groups to do Activity 15.3 on identifying the

causes and effects of noise pollution as outlined in the student's book page 466.

- Ask the learners to switch on the radio to full volume for 2 minutes and to low volume. Let them wait for some minutes and observe what happens.
- Ask them to discuss the meaning of noise pollution.
- Ask them to outline the causes of noise pollution in their environment and name some places in Rwanda where noise pollution is highly experienced. Allow them to conduct a research from the internet and reference books about the effects of noise pollution to the general public.
- Encourage the learners to discuss their findings with rest of the class. Such discussion and presentation improves the communication skills of the learners.

#### **Synthesis**

Having done the activity, guide the learners through a class discussion to appreciate that:

- Any undesired sound that is disruptive or dangerous and can cause harm to life, nature, and property is called noise pollution. It is often said that noise differs from other forms of pollution in that, unlike atmospheric pollutants for example, once abated, noise leaves no residual accumulation in the environment or the human body.
- Negative impacts of noise pollution include Physiological problems, Emotional problems, disrupts sleep

and communication, disrupts the natural order of activities in an ecosystem; for example, the feeding and breeding of livestock the wildlife on land and marine ecosystems is disrupted by noise, Structural damage to property like buildings as outlined in the student book on page 466 and 467.

#### **Assessment**

Ask the learners to do exercise 15.2 given in the student book page 467-468.

#### **Answers to Activity 15.3**

In step 2, Noise pollution is undesired sound that is disruptive or dangerous and can cause harm to life, nature, and property.

In step 3, cause of noise pollution include, noise pollution due to traffic and transport (that is surface transport by road, air transport), industries and factories (machines being operated), domestic and neighborhood sources (from gadgets, machines like blenders, some people use generators, loud speakers) places in Rwanda include near the airport in Kicukiro district (Kanombe) and the industrial area (Ruganda)

In step 4, effects of noise pollution include physiological problems, emotional problems, structural damage, it disrupts sleep and communication.

### **Lesson 5: Air pollution**

#### **Learning objective**

The learner should be able to explain the meaning of air pollution and its effects to the general public.

## Teaching Aids

- Match box
- Dry heap of litter in the school compound
- Reference books
- Internet.

## Introduction to the lesson

- The previous lesson was talking about noise pollution, by now the learners have an idea about pollution. Introduce the lesson by asking learners to suggest what they think of air pollution getting the insight from noise pollution.

## Learning Activities

### Teaching guidelines for Activity 15.4

- Organize the learners in pairs to do Activity 15.4 as outlined in the student book page 468. The activity is meant to help the learners appreciate the definition of air pollution.
- Ask them to collect litter in the compound and heap it in the pit far away from the buildings.
- Ask them to use a matchbox to light the litter and observe the smoke coming out of it.
- Ask them to use Fig. 15.4 to observe what is taking place.
- Let them briefly discuss the meaning of air pollution.
- Ask them to use reference books and Internet to explain the effects of air pollution to the general public.
- From each group, let one member discuss their findings to the whole class.

## Synthesis

Having done the activity, guide the learners through a class discussion to understand that:

- Air pollution is the introduction of harmful substances including particulates and biological molecules into the earth's atmosphere. It's also a mixture of solid particles and gases in the air.

### Answers to activity 15.4

In step 2, smoke is seen to move out of the burning litter.

In step 3, smoke is seen to come out of the chimneys in the industries.

In step 4, air pollution is the introduction of gases, dust particles, fumes (or smoke) that are harmful to humans, animals and plants into the atmosphere.

In step 5, effects of air pollution include acidification, eutrophication, eye irritation, nose throat and upper respiratory infections like bronchitis, headaches, nausea and allergic reactions.

## Causes of air pollution

### Preparation to the lesson

As a teacher, talk over a trip with your students to the director of studies (DOS). Let him/her talk it with the headmaster as they debate about how it will be conducted and mostly knowing where the funds will come from. It's good to involve in the heads of the school.

### Learning activity

### Teaching guidelines for Activity 15.5

- As a teacher, organize a trip with the students to a place in Rwanda with industries. And while there;



- Ask the learners to observe and make a report on the way industries pollute the environment and measures the industries have taken to minimize the pollution.

#### Synthesis

- During the trip, ask learners to be careful with their lives as they are very delicate.
- After the trip, guide the learners to explain the many human activities that result in air pollution as the ones listed in the student book on page 469-470 and from natural events like forest fires, volcanic eruptions, and wind erosion, evaporation of organic compounds in the atmosphere, pollen disposal, and natural radioactivity.
- Discuss with the learners and let them air out their findings from the trip they went to.

#### Answers to activity 15.5

In step 1, some of the ways through which the industries pollute the environment include;

- They emit smoke and pollute air and water very badly.
- Undesirable gases like carbon monoxide and sulphur dioxide cause air pollution.
- Industrial effluents are discharged into rivers. They include both organic and inorganic matters like dyes, soaps, pesticides.
- Industrial water contains toxic metals that pollute land and soil.
- Unwanted loud noise causes noise pollution.

- Sometimes the solid harmful substances are dumped in isolated pockets of land. This results in pollution of land and soil in the nearby regions.

Ways to minimize pollution include;

- Tall chimneys should be installed for vertical dispersion of pollutants.
- More trees should be planted along road sides and houses.
- Use of better designed equipment and smokeless fuels, hearths in industries and at homes.
- Sewage should be treated before it is discharged into the river or ocean.
- Waste food material, paper, decaying vegetables and plastics should not be thrown into open drains.
- Highway noise pollution can be mitigated by constructing noise barriers.
- National parks and conservation forests should be established by the government.

#### Effects of air pollution

#### Learning activity

#### Teaching guidelines for Activity 15.6

- Organize the learners into pairs to do activity 15.6 as outlined in the student book page 470. The activity is meant to help them appreciate and identify the effects of air pollution.
- Encourage the learners to discuss their findings with rest of the class. Such discussion and presentation improves the communication skills of the learners.

### Synthesis

Through a class discussion, help all learners to understand;-

- The major effects of air pollution to the environment as discussed in the student book page 470.
- The prevention, monitoring and the control of air pollution which involve collaborative efforts between government and by individuals actions (see the student book page 471)

### Assessment

Ask the learners to do exercise 15.3 given in the student book page 471.

### Answers to Activity 15.6

In step 1, problems faced as a result of air pollution include;

- i) Chemical reactions involving air pollutants create a poisonous gas ozone (O<sub>3</sub>). Gas Ozone can affect people's health and can damage vegetation types and some animal life too.
- ii) Acidification: Chemical reactions involving air pollutants can create acidic compounds which can cause harm to vegetation and buildings
- iii) Eutrophication: Rain can carry and deposit the Nitrogen in some pollutants on rivers and soils. This will adversely affect the nutrients in the soil and water bodies.
- iv) Health effects can include chronic respiratory disease, lung cancer, heart disease, and even damage to the brain, nerves, liver, or kidneys. Continual exposure to air pollution affects the lungs of growing children and may aggravate or complicate medical conditions in the elderly

In step 2, measures to curb the problem of air pollution

- i) It can be reduced by conserving energy by turning off lights, computers, air conditioners and other appliances when not in use.
- ii) Reduce the use of automobiles.
- iii) Plant more trees.

### Lesson 6: structure and composition of the atmosphere

#### Learning objective

The learner should be able to describe the basic composition, structure and dynamics of the atmosphere.

#### Teaching Aids

- Plain paper
- Reference materials
- internet

#### Introduction to the lesson

The learners have already looked at the composition of the earth's atmosphere in unit 14. Introduce the lesson by asking them to define the atmosphere and name gases that make up the atmosphere.

#### Learning Activities

##### Teaching guidelines for Activity 15.7

- Organize the learners in groups to do Activity 15.7 on describing the structure of the atmosphere as outlined in the student's book pages 472.
- Ask them to do research from reference books or internet and name the components that make up the atmosphere and draw the structure of the atmosphere.

- Let them draw its structure on a plain piece of paper.
- In their groups, let them pick one member to discuss to the class their findings.

### Synthesis

Having done the activity, guide the learners through a class discussion to understand that:

- The atmosphere of the earth is the layer of gases commonly known as air that surrounds the planet earth and is held in place by the earth's gravity. The air consists of a mixture of nitrogen (78%), oxygen (21%), and other gases (1%) that surrounds Earth.
- The atmosphere is structured into five (5) layers and that is the troposphere, stratosphere, mesosphere, thermosphere and the exosphere as discussed in the student book on page 472-473.
- The importance of the atmosphere as discussed in the student book on page 467.

### Answers to activity 15.7

- In step 1, the atmosphere is the layer of gases that surrounds the earth and is held in place by earth's gravity. The gases include nitrogen (78%), oxygen (21%), argon (1%) and trace amounts of carbon dioxide, neon, helium, methane, krypton, hydrogen, nitrous oxide, xenon, ozone, iodine, carbon monoxide and ammonia. Lower altitudes also have quantities of water vapor.
- In step 2, the structure of the atmosphere is on page 472-473 of the student book

- In step 4, the ozone is found in the stratosphere.

## Lesson 7: Climate science

### Learning objective

The learner should be able to explain the climate change science and appreciate that all environmental processes are interdependent.

### Teaching Aids

- Internet
- Reference books

### Introduction to the lesson

Introduce the lesson by asking them to differentiate between weather and climate

### Learning Activities

#### Teaching guidelines for Activity 15.8

- Organize the learners into pairs to do Activity 15.8 to differentiate between weather and climate as outlined in the student book page 474.
- Let them look outside and observe if there is sunshine, rain, cloudy or any description.
- Ask them to briefly discuss the difference between weather and climate.
- Such discussion and presentation improves the communication skills of the learners

### Synthesis

Use a class discussion to help learners recognize the fact that;

- Weather is the short-term state of the atmosphere, which may be hot or cold, wet (rainy) or dry, calm or stormy,

clear or cloudy while Climate is the average of the prevailing weather conditions in a region over a long period of time, usually a year.

#### Answers to activity 15.8

- In step 1, the answer will depend on that day.
- In step 2, weather is the short-term state of the atmosphere, which may be hot or cold. Climate is the average of the prevailing weather conditions in region over a long period of time, usually a year.

#### Learning activity

##### Teaching guidelines for Activity 15.9

- Organize the learners into appropriate groups putting into consideration gender balance.
- Ask them to do activity 15.9 on describing climate change as outlined in the student's book page 474.
- Ask them to discuss the meaning of climate change, eight causes of climate change, the effects of climate change and the measures that can be taken to reverse and minimize climate change.
- Ask them to share their findings to the rest of the class.

#### Synthesis

The learners having done and reported their findings, hold a discussion to;

- Guide the learners through a discussion given in the student book pages 474-475.
- Emphasize that climate change refers to the large-scale changes in the long-term averages of weather patterns.

- Emphasize on some natural causes of climate change as explained in the student book on page 475.
- Let them know that even humans cause climate change by involving in activities that lead to ozone layer depletion and greenhouse effect. This will be discussed further in the next lesson on page 475 and 479 respectively.

#### Answers to activity 15.9

- In step 1, climate change refers to the large-scale changes in the long-term averages of the weather patterns.
- In step 2, causes of climate change include; continental drift, volcanoes, the earth's distance from the sun, earth's tilt, ocean currents, ozone layer depletion and greenhouse effect.
- In step 3, climate change like warming of the earth's climate has caused some snow and ice to melt. The warming also has caused oceans to rise. And it has changed the timing of when certain plants grow.

Ways of reducing climate change include reducing the ozone layer depletion and emission of greenhouse gases to reduce greenhouse effect.

#### Ozone layer depletion

##### Learning objective;

The learner should be able to explain ozone layer depletion.

##### Teaching Aids

- Reference books
- Internet

## Learning Activities

### Teaching guidelines for Activity 15.10

- Organize the learners into pairs.
- Guide them to do activity 15.10 given in the student's book on describing ozone layer and ozone layer depletion as outlined on page 475-476.
- Ask them to discuss in pairs from their research ozone layer, its role and where it is found in the atmosphere.
- Let them brainstorm on the role of the ozone layer in the atmosphere.
- Ask them to state the human activities that cause the depletion of the ozone layer.
- Ask them to discuss what the government of Rwanda should do about the protection of the ozone layer.
- Ask one member from at least three group to discuss to the class their findings.

### Synthesis

Having done the activity, guide the learners through a class discussion given in the student's book pages 476-477.

- Let them understand that the ozone layer is simply a layer in the stratosphere containing a relatively high concentration of ozone.
- Guide them through how ozone is formed.(see student book page 476)
- Emphasize on how the ozone protects the people and plants from the dangerous UV rays from the sun.
- Emphasize that ozone layer depletion is simply the wearing out (reduction) of the amount of ozone in the stratosphere.

- Causes of the ozone layer depletion as discussed in the student book on page 476.
- The measures taken globally and by Rwanda to protect the ozone layer as discussed in the student book on page 477.

### Assessment

Ask the learners to complete exercise 15.4 in the student book page 478-479.

### Answer to Activity 15.10

- In step 1, this is simply a layer in the stratosphere containing a relatively high concentration of ozone. Ozone is a molecule made up of three atoms of oxygen. It works a lot like sunscreen, blocking out harmful ultraviolet (UV) rays from the sun.
- In step 2, the ozone is found in the stratosphere.
- In step 3, it works a lot like sunscreen, blocking out harmful ultraviolet (UV) rays from the sun from reaching the earth.
- In step 4, human-produced chemicals are responsible for the observed depletions of the ozone layer. The ozone-depleting compounds contain various combinations of the chemical elements chlorine, fluorine, bromine, carbon, and hydrogen and are often described by the general term halocarbons. Another important group of human-produced halocarbons is the halons, which contain carbon, bromine, fluorine, and (in some cases) chlorine and have been mainly used as fire extinguishants.
- In step 5, Rwanda should;-

- (i) Urge other nations to pass an ambitious amendment to the Montreal protocol on ozone depleting substances, which if there's failure to act would increase risks of skin cancer and global warming.
- (ii) Regulate importation and exportation of ozone layer depleting substances, products and equipment containing such substances ozone depleting substances (ODS).

## **Greenhouse effect and Global Warming**

### **Learning objective**

The learner should be able to explain global warming and greenhouse effect.

### **Teaching Aids**

- A greenhouse structure
- Reference books
- Internet

### **Learning Activities**

#### **Teaching guidelines for Activity 15.11**

- Organize the learners in groups to do Activity 15.11 on explaining the greenhouse effect as outlined in the student's book page 479.
- This activity is well done if learners are taken to a greenhouse structure where horticultural plants are grown.
- Let the learners ask the greenhouse attendant how the greenhouse accelerates the growth of plants.
- Ask them to explain greenhouse effect and explain its causes.

- Ask one member to discuss their findings to the rest of the class. Such discussion and presentation improves the communication skills of the learners among other competences.

### **Synthesis**

Having done the activity, guide the learners through a class discussion to appreciate that:

- Greenhouse effect is the trapping of the sun's warmth in a planet's lower atmosphere due to the greater transparency of the atmosphere to visible radiation from the sun than to infrared radiation emitted from the planet's surface.
- Causes of the greenhouse effect as discussed in the student book on page 480.
- Emphasize the main impact of greenhouse effect is global warming.
- Guide them through a discussion on global warming. let them know is the term used to describe a gradual increase in the average temperature of the Earth's atmosphere and its oceans, a change that is believed to be permanently changing the Earth's climate.
- The effects of global warming to the world today as discussed in the student book on pages 480-481 .
- The measures that can be taken to reduce the greenhouse effect and global warming and the applications of the greenhouse effect.

### **Assessment**

Ask the learners to do exercise 15.5 in the student book page 481-482.



### Answers to activity 15.11

In step 2, a greenhouse is a house made of glass. It traps the sun's energy inside and keeps the plants warm, even in winter. It has glass walls and a glass roof. People grow tomatoes and flowers and other plants in them. A greenhouse stays warm inside, even during winter. Sunlight shines in and warms the plants and the air inside. But the heat is trapped by the glass and can't escape. So during the daylight hours, it gets warmer and warmer inside a greenhouse, and stays pretty warm at night too.

In step 3, Greenhouse effect is the trapping of the sun's warmth in a planet's lower atmosphere due to the greater transparency of the atmosphere to visible radiation from the sun than to infrared radiation emitted from the planet's surface.

In step 4, causes of the greenhouse effect include;

- i) Burning coal, oil and gas
- ii) Cutting down forests
- iii) Increasing livestock farming
- iv) Use of fertilizers containing nitrogen
- v) Production of fluorinated gases.

### Lesson 8: The Hydrosphere and Hydrologic cycle

#### Learning objective.

The learner should be able to explain the principle of hydrologic cycle and the mechanism of water transport in the atmosphere and the ground.

#### Teaching Aids

- Internet
- Reference books

### Learning Activities

#### Teaching guidelines for Activity 15.12

- Organize the learners in pairs to do Activities 15.12 on describing the hydrosphere as outline in the student book page 482.
- Ask them to use the internet and reference books to describe the hydrosphere.
- Let them share their ideas and one student each group discuss to the whole class.

#### Synthesis

Use a class discussion to help learners consolidate the facts in order to clearly understand;

- The hydrosphere describes the combined mass of water found on, under, and over the surface of a planet or is the liquid water component of the Earth. It includes the oceans, seas, lakes, ponds, rivers and streams. Hydrology is the study of water.

#### Answers to activity 15.12.

In step 1, the hydrosphere describes the combined mass of water found on, under, and over the surface of a planet or is the liquid water component of the Earth. It includes the oceans, seas, lakes, ponds, rivers and streams. The hydrosphere covers about 70% of the surface of the Earth and is the home for many plants and animals. The hydrosphere is the world of water that surrounds all of us.

#### Hydrological cycle

#### Teaching Aids

- Manila paper

- Reference books
- Internet

### Learning activity

#### Teaching guidelines for Activity 15.13

- Organize the learners into pairs.
- Guide them to do activity 15.13 given in the student's book on describing the hydrological cycle as outline in the student book page 483.
- Ask them to use the internet and reference books to identify the elements in the hydrologic cycle.
- Ask them to use the Manila paper to illustrate the hydrological cycle with a diagram.
- Let them discuss uses of water
- Let them share their ideas and one student each group discuss to the whole class. Such discussion and presentation improves the communication skills of the learners

#### Synthesis

Having done the activity, guide the learners through a class discussion to appreciate that:

- The hydrologic cycle is the natural sequence through which water passes into the atmosphere as water vapor, precipitates to the earth as a liquid or solid form and ultimately into the atmosphere through evaporation.
- Guide them through a discussion about how the hydrological cycle takes place. (see student book pages 483-484)
- Importance of Liquid Water as discussed in the student book on page 484.

#### Assessment

Ask the learners to do questions 1-3 of exercise 15.6 given in the student book page 485.

#### Answers to Activity 15.13

- In step 1, the elements of the hydrological cycle include evaporation, condensation, precipitation, deposition, runoff, infiltration, sublimation, transpiration, melting, and groundwater flow.
- In step 2, the hydrological cycle is on page 483-484 in the student book.

In step 3, some of the uses of water include;

1. Water serves as a lubricant in digestion and all other body processes.
2. Water is important to the mechanics of the human body. All the cell and organ functions that make up our entire anatomy and physiology depend on water for their functioning
3. Water regulates body temperature. Our bodies can control over heating through perspiration from several sweat glands in the skin and from evaporation which brings a cooling effect.
4. Water is used for power generation
5. Water is used for recreation purposes
6. Water is a habitant for marine animals
7. Water is used in plants.

### Lesson 9: Clouds, cyclones and anticyclones

#### Learning objective

The learner should be able to define a cloud and name some types of clouds

### Teaching Aids

- Open ground
- Manila paper
- Internet
- Reference books

### Learning Activities

#### Teaching guidelines for Activity 15.14

- Organize the learners in pairs to do Activity 15.14 in the student's book to define a cloud and name some types as outlined on page 485-486.
- On that day of the lesson, move out with the learners into the open ground.
- Ask them to look high and observe the clouds. Let them identify different types based on their colors and height above the ground and note them down in their note books.
- Ask them to move to class and use the internet and reference books to identify the types of clouds they observed. Ask them to prepare a table on the manila and fill in the information they gathered.
- Ask them to explain how clouds are formed and what caused rain.
- Ask the learners to brainstorm and pick one student from each group to discuss to the class

#### Synthesis

Having done the activity, guide the learners through a class discussion to understand that:

- Cloud are made of water drops or ice crystals floating in the sky.
- Emphasize how clouds get their names (see student book pages 486-487)

- Guide the learners through a discussion about how clouds are formed.
- Guide the learners through a discussion on the different types of clouds as discussed in the table on page 481-487.

#### Assessment

- Ask the learners to do concept Exercise 15.9 given in the student book page 481.

#### Answer to Activity 15.14

- In step 1, cirrus clouds, cumulus clouds, stratus and nimbus clouds.
- In step 4, solar radiation heats the ground and the air immediately above it. Clouds forms when rising air, through expansion, cools to the point where some of the water vapor molecules clump together faster than they are torn apart by their thermal energy. As the air rises, the temperatures decrease and so does the amount of water vapor that the air can hold. Some of that (invisible) water vapor condenses to form cloud droplets.

### Lesson 10: Cyclone and anticyclone

#### Learning objective

The learner should be able to define and differentiate between cyclone and anticyclone

#### Learning objective.

By the end of the lesson the learners should be able to explain the formation of cyclone and anticyclone.

## Teaching Aids

- Basin
- Atlas
- Internet
- Reference books

## Learning Activities

### Teaching guidelines for Activity 15.15

- Organize the learners in groups to do Activity 15.15 in the student's book page 488. The activity is meant to help the learners appreciate the formation of cyclones and anticyclones.
- Go through each group and ensure that they are doing the right thing. Note that some students may not know clockwise and anticlockwise. It's on this note that you can come in to explain step 2 and 3 of the activity.
- Ask them describe what cyclone and anticyclones are.
- Ask the learners to brainstorm and pick one student from each group to discuss to the class

### Synthesis

- Learners having done the activity, lead them through a class discussion provided to them in the student book and help them to define cyclones as a storm or system of winds that rotates around a center of low atmospheric pressure while an anticyclone is a system of winds that rotates around a center of high atmospheric pressure.
- Guide them through a discussion about how each one is formed and how they move as discussed in the student book pages 488-490.

## Answers to activity 15.15

- In step 2, the water moves and makes a depression but in the clockwise direction.
- In step 3, the water moves and makes a depression but in the anti-clockwise direction.
- In step 4, a cyclone is a large-scale, atmospheric wind-and- pressure system characterized by low pressure at its center and by circular wind motion, counterclockwise in the northern hemisphere, clockwise in the southern hemisphere. An anticyclone is the large-scale circulation of winds around a central region of high atmospheric pressure, clockwise in the northern hemisphere, counter clockwise in the southern hemisphere. Or simply a cyclone is a storm or system of winds that rotates around a center of low atmospheric pressure. An anticyclone is a system of winds that rotates around a center of high atmospheric pressure.

## Lesson 8: Global Convection currents and wind patterns

### Learning objective

The learner should be able to global Convection currents and wind patterns

### Teaching Aids

- Atlas
- Internet
- Reference books

### Learning Activities

#### Introduction to the lesson

The learners have already studied about heat transfers. Introduce the lesson by

asking the learners to define some forms of heat transfer.

### Learning Activities

#### Teaching guidelines for Activity 15.16

- Organize the learners in pairs to do Activity 15.16 in the student's book page 490. This activity is meant to help the learners define and explain the formation of global wind patterns.
- Ask them to describe heat transfer by convection.
- Ask them to use an atlas and the Internet to describe the global convection currents and note down the facts in their books.
- Ask the learners to brainstorm and pick one student from each group to discuss to the class

#### Synthesis

Having done the activity, guide the learners through a class discussion to understand that:

- Convection is the transfer of heat energy by the movement of a liquid or gas.
- Guide the learners through a discussion on the six global wind belts as discussed in the student book page 491 and 492.
- Lead the learners through a discussion on the importance of wind as outlined in the student book page 492.

#### Answers to activity 15.16

In step 1, Convection is the transfer of heat energy by the movement of a liquid or gas where a hot fluid rises and the cold one sinks causing convection currents.

In step 2, the global convection currents (global wind belts) are polar and tropical easterlies, trade winds, doldrums, horse latitudes, intertropical convergence zone, and the prevailing westerlies. (see page 492)

### Lesson 12: Thermoregulation and physics laws that govern it

#### Learning objective

The learner should be able to explain thermoregulation.

#### Teaching Aids

- Reference books
- Internet

#### Learning Activities

#### Teaching guidelines for Activity 15.17

- Organize the learners in pairs to do Activity 15.17 in the student's book page 492. This activity is meant to help the learners define thermoregulation.
- Ask them to define the term thermoregulation and explain how it works.
- Ask the pair to report their answers to the rest of the class. Through class discussion help them to identify the pairs who may not have gotten the answers right and guide them and the rest of the class to know thermoregulation.

#### Synthesis

The learners having done the activity and reported their findings, hold a discussion to;

- Guide the learners through a discussion given in the student book pages 492-495.

- Emphasize that thermoregulation is the process that allows the human body to maintain its core internal temperature.
- Guide the learners through a discussion on the physics laws that govern thermoregulation as discussed in the student book page 493.
- Guide them through a discussion on the modes of heat transfer in relation to thermoregulation as discussed in the student book page 494.
- Emphasize on Newton's law of cooling that it states that the rate at which energy is lost from the body is directly proportional to the difference between the body's temperature and the environmental temperature.

#### Assessment

- Ask the learners to do Exercise 15.18 given in the student book page 495.

#### Answer to Activity 15.17

- In step 1, thermoregulation is a process of maintaining a constant body's internal core temperature despite temperature changes in the external environment.
- In step 2, when your brain receives a temperature warning from your body, it sends signals to various organs and body systems, which try to slow or increase heat production. A section of your brain called the hypothalamus controls thermoregulation. It issues instructions to your muscles, organs, glands, and nervous system when it senses your core internal temperature is becoming too low or too high.

#### Summary of Unit

Summarize the unit by:

- Asking different learners to take the different concepts highlighted in the unit summary given in the learner's book pages 495-498. Ask the class probing questions to help them recall the concepts correctly.
- Ask the learners to now describe a solution to the problem they faced at the start of the lesson. After their response, ensure that the learners are able to;
  1. Explain how the global climate has changed, and the causes and impacts of climate change in the world, and ways in which we can control climate change.
  2. Explain causes and impacts of noise pollution, air pollution and how pollution can be minimized generally.
  3. Explain the laws of physics and mainly laws of thermodynamics and modes of heat transfer govern processes in our environment.

#### Additional information to the teacher

- It is important as a teacher to know following facts:

#### Clouds

- Clouds form when water vapor rises into the atmosphere and condenses onto microscopic particles, such as dust, dirt and sea salt.
- When the sun heats water in the oceans, rivers, lakes and other sources, some of it evaporates, or transforms from liquid water to water vapor. With enough heat, water in soils and sediments also evaporates. Additionally, plants transpire, or



“sweat out,” water vapor from their leaves and stems (similar to way people release water vapor when exhaling).

- Some of this water vapor makes its way into the atmosphere through a process called convection, in which hotter, less-dense parcels of air rise, while cooler, denser parcels sink.
- Because atmospheric pressure decreases as altitude increases, the water vapor experiences less pressure the higher it rises. With less pressure, the water vapor expands. As it does so, it loses energy, causing it to cool.
- Eventually the air reaches the dew point temperature — the temperature at which the air becomes saturated with water vapor. Below this temperature, some of the water vapor begins to condense, or transform from a gas to a liquid.
- However, water typically only undergoes condensation when it’s in contact with a solid surface; this is where the microscopic particles of dust or salt in the atmosphere (also called cloud condensation nuclei, or cloud seeds) come into play. When enough of the water vapor condenses on the cloud seeds, a visible cloud forms.
- Thermoregulation
- The state of having an even internal temperature is called homeostasis. All thermoregulation mechanisms are designed to return the body to homeostasis.
- A healthy, safe temperature is between 37°C and 37.8°C. Within a few degrees less or above that range,

signs related to body temperature changes may be experienced. For example, if your body temperature falls just 3 degrees to 95°F (35°C), you might experience hypothermia. Hypothermia can cause cardiac arrest, stroke, or even death. At 107.6 °F (42 °C), you could suffer brain damage as a result of temperatures that are too high.

- A section of your brain called the hypothalamus controls thermoregulation. It issues instructions to your muscles, organs, glands, and nervous system when it senses your core internal temperature is becoming too low or too high.
- Types of Thermoregulation:
- When your brain receives a temperature warning from your body, it sends signals to various organs and body systems, which try to slow or increase heat production.
- If your body needs to cool down, these include:
  - Sweating: Sweating is one of the first methods your body will use to control your temperature. Sweat cools your skin as it evaporates. This helps lower your internal temperature.
  - Vasodilatation: Your CNS may instruct the capillaries under the surface of your skin to dilate, or open. Vasodilatation, or enlarged capillaries, increases blood flow at the skin surface. This lets your body release heat through radiation.
- If your body needs to warm up, these include:
  - Stopping sweating: Your nervous system can lower sweat production to help maintain the heat your body generates.

- **Vasoconstriction:** Your CNS may signal your capillaries to constrict, or become narrower. This decreases blood flow under the skin and reduces heat loss.
- **Thermogenesis:** Your body's muscles, organs, and brain can produce heat when your internal temperature is sinking. This process is called thermogenesis. Muscles are especially effective at thermogenesis. They can produce large quantities of heat quickly. Shivering is one way muscles generate heat.
- **Hormonal thermogenesis:** Your body can activate the thyroid gland if you are getting too cold. This releases hormones that increase your metabolism. An increased metabolism increases the energy your body creates and the amount of heat your body is able to make.

#### End of unit assessment

- Ask the learners to the Unit Test 15 given in the student book pages 499-500.

#### Remedial activity for slow learners.

1. What are some of the actions that a student can take to reduce air pollution?
2. What is the difference between climate change and global warming?
3. Why is it a problem if the earth's average temperature gets a little warmer?

#### Answers to remedial activities/questions for slow learners

1. The actions include;
  - i) Avoid burning leaves, trash and other materials. Put them in a compost pit.
  - ii) Reduce the use of aerosols in the household.
  - iii) Switch off all the lights, and fans when not required.
  - iv) Plant trees around your home and look after the trees in the neighborhood.
  - v) As far as possible, use public forms of transport.
2. Global warming is the increase in the temperature near the earth's surface while climate change is the large scale changes in the long-term averages of the weather patterns.
3. There are some noticeable impacts like;
  - i) Rising of the sea levels because of melting of the ice.
  - ii) Some animals die because they live only in cold areas.
  - iii) There can be risk of wildfires.

#### Remedial activity for gifted learners.

1. Why is climate change happening?
2. What is the greenhouse effect and how does it affect the climate.
3. Define the ozone hole

#### Answers for remedial activity for gifted students

1. The main reason climate is changing is that people add greenhouse gases to the atmosphere. The gases trap extra heat making the planet warmer.

2. The greenhouse effect is a natural process that helps make the earth warm enough for us to live. The earth gets energy from the sun, heats up, and then gives off energy back to the atmosphere. The greenhouse gases in the atmosphere trap some of this energy before it escapes to the outer space. The people's activities that add extra greenhouse gases make the greenhouse effect stronger and the earth becomes warmer.
3. The ozone hole is a decrease in the layer of the ozone found in the earth's atmosphere.

### Answers to Exercises and Unit Test

#### Exercise 15.1

(Learner's book page 465)

1. A
2. A
3. a) The first law of thermodynamics states that the energy doesn't change because there is no increase or decrease in total energy. This is because the kinetic energy and potential energy can increase or decrease. If it is a closed system, then no heat will be transferred with the outside and any change in the internal energy will be due to work done or by the system. If it does work on the environment, then it will lose energy (internal energy) but if the work is done on the system, then it will gain energy.
- b) Second law of thermodynamics
- c) From the first law of thermodynamics, the increase of thermal energy of a cool objects equals \ the decrease of the thermal energy of the warm object
4. From the definition of temperature as the average kinetic energy of particles in a body, so the more the particles means them more movement and so the more energy. Also from the equation of quantity of heat, where C is the specific heat capacity, M is the mass and T is the temperature. Since mass is a component of the total heat energy in the substance, then the answer is 2L of water at 50 °C.
5. Conduction because in conduction particles with heat move fast and knock their neighbors hence transmitting heat to them, while convection, particles which gain heat become less dense and rise to the top, and these ones are already on the top so they can't go down just because they are less dense. (Please correct the question by continuing after heat transfer and you say heat transfer by conduction or by convection? explain)
6. It is true. Thermal energy is the energy of a substance due to its temperature, as thermal energy changes, the temperature of the body also changes.
7. Radiation is the transfer of energy by electromagnetic waves. Radiation does not necessarily require a material medium for the heat energy to flow through. Conduction is the transfer of thermal energy or movement of heat through a substance without the substance itself moving. Heat can be conducted between two bodies, which are in contact with each other. Convection is the transfer of heat energy in a fluid by the movement of warmer and cooler fluid from place to place.

8. Cool air is always more dense than warm air. On the floor, the cool air is warmed through different methods like breathing because it contains oxygen and other appliances, which warm up during use, heat up the air on the floor. When its heated, it expands and becomes less dense hence rising to the ceiling.
9. Insulators are materials, which don't allow the flow of heat through them easily, and conductors allow heat to flow them easily.

### Exercise 15.2

(Learner's book page 467-468)

1. D
2. D
3. A
4. D
5. C
6. Noise pollution is undesired sound that is disruptive or dangerous and can cause harm to life, nature and property.
7. The most causes of noise pollution include;
  - i) Industrial and construction activities
  - ii) Moving aircrafts and vehicles
  - iii) House hold appliances like radios
  - iv) Machines like lawn mowers and tractors
8. The negative effects of noise pollution include;
  - i) Noise disrupts sleep and communication
  - ii) Noise causes structural damage to property like buildings due

to vibrations induced by sound waves

- iii) Noise disrupts the natural order of activities for example feeding and breeding of livestock.
- iv) Noise causes physiological problems
- v) Noise brings about emotional problems such as irritability and nervousness.

### Exercise 15.3

(Learner's book pag 471)

1. C
2. D
3. C
4. A
5. D
6. The increase in the levels of carbon dioxide into the atmosphere has direct effect on
  - i) There is acidification as oceans and other large water bodies absorb carbon dioxide from the atmosphere.
  - ii) It increases greenhouse effect. This leads to warmer temperatures which are high and this might cause drought in the long run
7. The effects of noise pollution include;
  - i) Acidification: This is a chemical reaction involving air pollutants creating acidic compounds in the atmosphere. When these compounds dissolve in rain drops, they form in acidic rain. When acid rain falls over in an area, it can corrode iron sheets, kill

trees and harm livestock, wildlife and aquatic animals like fish. In the soil, the acid changes the chemistry of the soil making it unfit for microorganisms.

- ii) Eutrophication: This occurs when rainwater dissolve chemicals like nitrogenous compounds in the atmosphere then drain into water bodies and soils. The compounds, being nutrients, result in excessive algae growth that may cause death of living organism due to lack of oxygen.

#### Exercise 15.4

(Learner's book page 478-479)

1. A
2. A
3. A
4. 2
5. B
6. A
7. D
8. B
9. C
10. A
11. a) The ozone in the atmosphere is created by ultraviolet light striking ordinary oxygen molecules containing two oxygen atoms, this ends up splitting them into individual atoms. The oxygen atom now combines with the unbroken oxygen because it is unstable and forms ozone.
- b) The atmospheric ozone is cared about because it plays a beneficial role of absorbing most of the

biologically damaging ultraviolet sunlight there by allowing a small amount from reaching the earth's surface. The absorption of ultraviolet rays creates a source of heat thus ozone plays a part in the temperature structure of the atmospheres' temperature.

- c) No the total amount of ozone above the surface of the earth varies with location and time scales that range from daily to seasonal and longer. The variations are caused by stratospheric winds and chemical production and the destruction of the ozone. Total ozone is lowest at the equator and highest near the poles because of the seasonal wind patterns in the stratosphere.
12. Ozone is a molecule made up of three oxygen atoms. It is formed when High-energy ultraviolet (UV) light collides with the oxygen gas molecule (O<sub>2</sub>) causing it to split into two oxygen atoms (O<sub>1</sub>). These atoms are unstable on their own and bind themselves with the unsplit oxygen molecules forming ozone. The ozone is so important because it absorbs the sun's UV radiations from reaching the surface of the earth. The UV radiations it protects us from in humans, can cause skin cancer and cataracts, for animals it affects the fertility of some as well as the viability of their off springs. For plants it affects their ability to grow. UV radiations also influence how chemicals break down which can lead to catastrophic changes in the environment and ecosystems.
13. CFC's released into the environment, sunlight breaks CFC's up, releasing chlorine, chlorine reacts with ozone

and destroys it, and more reactions destroy or cause more depletion.

14. Human activities cause the emission of halogen source gases that contain chlorine and bromine atoms. The source gases that contain carbon, chlorine and fluorine are called chlorofluoro carbons.
15. Chlorine and bromine.
16. The depletion of the ozone layer leads, on the average to an increase in ground level ultraviolet radiation because ozone is the effective absorber of ultraviolet radiation.
17. To some extent yes, but there are also other causes of climate change like continental drift, volcanoes, ocean currents, greenhouse effect and most of all global warming.

#### Exercise 15.5

(Learner's book page 481-482)

1. B
2. A
3. C
4. B
5. A

#### Exercise 15.6

(Learner's book page 485.)

1. A
2. D
3. C
4. B
5. D
6. C
7. clouds

8. The hydrosphere is the combined mass of water found on, under, and over the surface of planet
9. The uses of water include;
  - i) Water is a key component of the blood that regulates the body temperature
  - ii) In plants, it is important in photosynthesis and is a medium of transport for nutrients in the plants
  - iii) Water is used in power generation
  - iv) Water is used in transport
  - v) Water is used as a habitat for aquatic life
  - vi) Water is used in many recreation activities like swimming
  - vii) Water is used in industries for cleaning, cooling and as an ingredient
  - viii) Water is used for domestic use like drinking and cooking
10. The water cycle is the continuous cycle where water evaporates, travels into the air and becomes part of clouds, and then later falls down to the earth as precipitation and then evaporates again.
11. Some ways of conserving water include
  - i) Shower attachments; a smaller showerhead consumes less water than that of a fixed head shower.
  - ii) Leaks. Long term leak can cause serious damage. It's better to trace for the leak by using infra-red technology or leak noise corrugators.



### Exercise 15.7

(Learner's book page 487)

1. A cloud is a visible mass of condensed water vapor floating in the atmosphere high above the ground. The different types of clouds include cirrus, cumulus, stratus, and nimbus clouds
2. They are cumulus clouds. It is because they are dense in appearance, have sharp outlines look like white fluffy balls.
3. Clouds form when water vapor rises into the atmosphere and condenses into microscopic particles, such as dust, dirt and sea salt. When the sun heats water in the oceans, rivers, lakes and other sources, some of it evaporates, or transforms from liquid water to water vapor. With enough heat, water in soils and sediments also evaporates. Additionally, plants transpire, or "sweat out," water vapor from their leaves and stems. Some of this water vapor makes its way into the atmosphere through a process called convection, in which hotter, less-dense parcels of air rise, while cooler, denser parcels sink. Because atmospheric pressure decreases as altitude increases, the water vapor experiences less pressure the higher it rises. With less pressure, the water vapor expands. As it does so, it loses energy, causing it to cool. Eventually the air reaches the dew point temperature. Below this temperature, some of the water vapor begins to condense, or transform from a gas to a liquid. However, water typically only undergoes condensation when it's in contact with a solid surface; this is where the microscopic particles of dust or salt in the atmosphere come

into play. When enough of the water vapor condenses on the cloud seeds, a visible cloud forms.

4. Dew point temperature is the temperature at which the air becomes saturated with water vapor.

### Exercise 15.8

(Learner's book page 495)

1. A
2. B
3. Evaporation is the process through which a liquid is transformed into vapor. For evaporation to take place, the liquid molecules absorb heat energy from the surrounding to change to gaseous state. As such evaporation causes cooling. For evaporation to take place, its fast moving atoms in the liquid (the ones with the highest kinetic energy-high temperature) which reach the surface of the liquid and break free from the intermolecular forces thus leaving the ones with less energy and low temperature.
4. The total energy produced in the body is called the metabolic rate ( $dM$ ). It is related to the total metabolic energy production of the body ( $dH$ ), and the external work done by the body ( $dW$ ), by the expression:  $dM = dH + dW$ . For example, if no mechanical work is done ( $dW = 0$ ), then the total chemical energy input in form of food is converted to thermal energy, i.e.  $dH = dU$ . If the human body does some work (i.e.  $dW \neq 0$ ), then the total chemical energy input in form of food is converted to thermal energy and the work done by the body, i.e.  $dM = dH + dW$

5. The factors include
  - i) The temperature of the surrounding
6. Ways of preventing heat loss from human beings are
  - i) By putting on jackets or sweaters made out of poor conductors of heat like cotton and wool.
  - ii) Going near fire places or making fire places in houses.
  - iii) Having heating systems in houses
  - iv) Warming ourselves by drinking some hot things
7. Hibernation is a state of inactivity in which an animal's heart rate, body temperature and breathing rate are decreased to conserve energy. When food is scarce, an animal may use up more energy maintaining its body temperature and searching for food than it would receive from consuming the food. So they end up going into hibernation. Heat is usually produced when in search of food through walking and running for food. When they hibernate no exercises are done so no heat production thus conserving the little they have.
8. Ways how animals dissipate excess heat include
  - i) Through sweating. Sweat is produced in the sweat glands, which are activated by the hypothalamus, the area in the brain that controls biological processes like body temperature. Sweat cools the animal's skin as it evaporates. This helps lower your internal temperature.

- ii) Animals which don't sweat or with few sweat glands regulate their temperature by panting which evaporates water from the moist lining of the oral cavity and pharynx.

### Unit Test 15

(Learner's book page 499-500)

1. B
2. B
3. A
4. C
5. D
6. A
7. C
8. A
9. C.
10. B
11. D
12. C
13. Causes of global warming include ;
  - i) Effect of greenhouse gases: This is where there is the absorption and emission of infra-red radiation by gases in the atmosphere which warm the earth's lower atmosphere and the surface. These gases include carbon dioxide and methane among others.
  - ii) Volcanic activity: fumes and heat releases by active volcanoes near Rwanda such as Nyiragongo in D.R.Congo has led to increase in temperatures.
  - iii) Effects of direct solar radiation cause a warming effect of the troposphere.

- iv) It is also caused by pollution especially through the burning of fossil fuels which give out carbon dioxide and methane gas.
  - v) High population: More people means more cars due to need for transportation which leads to pollution due to burning of more fossil fuels thus high amounts of carbon dioxide in the atmosphere which cause rise in temperatures.
  - vi) Methane emissions from animals and agriculture: This is produced when organic matter is broken down by bacteria under oxygen starved conditions which increase temperatures in the atmosphere.
  - vii) The effects of deforestation: Use of forests for fuel (charcoal and wood) lead to deforestation. Trees remove and store carbon dioxide from the atmosphere but deforestation lead to release of large amounts of carbon as well as reduce the amount of carbon capture which cause a rise in temperatures.
  - viii) Increase in usage of chemical fertilizers on croplands instead of using animal manure. Application of nitrogen rich fertilizers has effects on heat storage of cropland for example nitrogen oxides.
  - ix) Industrial development: Industries release fumes that contain greenhouse gases such as carbon dioxide and carbon monoxide that cause global warming.
- ii) Reduce waste. Landfills are the major contributor of methane and other greenhouse gases. When the waste is burnt, it releases toxic gases in the atmosphere which result in global warming.
  - iii) Reduce the use of fertilizers and use more of animal manure.
  - iv) Make Cars which use biofuels, solar power to reduce the emissions from cars that use petrol and grease.
  - v) Choose energy efficient appliances when making new purchases.
  - vi) Increase in wind and solar power
  - vii) Carbon dioxide emitted from burning of fossil fuels can be captured and stored underground in a process called carbon sequestration.

14. Global warming refers to the continuous rise in the average temperatures of the earth's climatic system. Climate change refers to the general modifications in the conditions of atmospheric weathers of a place leading to change in behavior of ecosystems and living organisms found in that pace. The cause of global warming is the increased amount of greenhouse gases in the atmosphere. Global warming is one of the aspects that bring about climate change. When these gases (burning of fossil fuels to produce energy industrial processes and transportation) are emitted into the atmosphere, they act like a blanket around the earth, trapping energy

Strategies to reduce global warming include

- i) Afforestation. Planting of trees where they don't exist and reforestation- increasing

in the atmosphere and causing it to warm. A warming climate can bring changes that can affect water supplies, agriculture, and power and transportation systems.

15. a) Ozone is a colourless gas made up of three oxygen atoms. It occurs naturally in the stratosphere in the upper atmosphere. The ozone protects the life of plants and animals on earth from the sun's UV radiations.
  - b) Ozone is formed in the atmosphere when Oxygen gas (two molecules of oxygen, or O<sub>2</sub>) is present in the atmosphere. High energy UV light collides with the oxygen molecule, causing it to split into two oxygen atoms. These atoms are unstable, and they prefer being "bound" to something else. The free oxygen atoms then smash into other molecules of oxygen, forming ozone.
  - c) The emissions include;
    - i) Vehicle emissions (from oil and petro engines)
    - ii) Refrigerants and aerosols sprays,
    - iii) CFC's from Styrofoam, plastics,
    - iv) burning certain chemicals that produce CFC's
    - v) Deforestation
    - vi) Industrial processes
16. An isolated system is a thermodynamic system that cannot exchange either energy or matter outside the boundaries of the system. This means that it is separated from its environment in such a way that no energy can flow in or out of the system. So the energy will remain constant
17. They are called chlorofluorocarbons.
  18. Chlorofluorocarbons.
  19. Refrigerators, takeaway containers, air conditioners, solvents, soaps and Insulating foams.
  20. Pollutants are substances or energy introduced into the environment that has undesired effects Chlorofluorocarbons are therefore called pollutants because when they are emitted into the atmosphere, they are broken down by UV radiation to release chlorine atoms. These atoms of chlorine later react with ozone starting a chemical cycle that destroys the ozone in that area. Yet it is the ozone layer which protects us from the UV radiations from the sun.
  21. The increased volume of carbon dioxide in the atmosphere has brought about global warming. Carbon dioxide is produced from the burning of fossil fuels like coal oil and natural gas, deforestation and industrial processes such as cement manufacturing. The gas molecules absorb thermal infrared radiation acting like blanket, preventing it from escaping into outer space. The net effect is the gradual heating of the earth's atmosphere and the surface, a process called global warming.
  22. The correct order for the principal steps in the depletion of the stratospheric ozone layer
    - i) Emissions "Halogen source gases are emitted at Earth's surface by human activities and natural processes"

- ii) Accumulation “Halogen source gases accumulate in the atmosphere and are globally distributed throughout the lower atmosphere by winds and other air motions”
- iii) Transport “halogens source gases are transported to the stratosphere by air motions”,
- iv) Conversion “most halogens source gases are converted in the stratosphere to reactive halogens gases in chemical reactions involving ultraviolet radiation from the sun”
- v) Chemical reaction “ reactive halogen gases cause chemical depletion of stratospheric ozone over the globe”
- vi) Removal “ air containing reactive halogen gases returns to the troposphere where the gases are removed by moisture in clouds and rain”.